

## Polypropylene Film Capacitor

### Related Document: IEC 60384-13

**MAIN APPLICATIONS:**

Oscillator, timing and LC/RC filter circuits, high frequency coupling of fast digital and analog IC's.

**MARKING:**

Manufacturer's logo/type/C-value/rated voltage/tolerance/date of manufacture

**DIELECTRIC:**

Polypropylene film

**ELECTRODES:**

Metal foil

**COATING:**

Flame retardant plastic case (UL-class 94 V-0), color blue, epoxy resin sealed

**CONSTRUCTION:**

Extended foil (refer to general information)

**LEADS:**

Tinned wire

**IEC TEST CLASSIFICATION:**

55/100/56, according to IEC 60068

**OPERATING TEMPERATURE RANGE:**

- 55°C to + 100°C

**CAPACITANCE RANGE:**

100pF to 0.033μF

**CAPACITANCE TOLERANCES:**

± 10% (K), ± 5% (J), ± 2.5% (H), ± 1% (F)

**RATED VOLTAGES (U<sub>R</sub>):**

63 VDC, 250 VDC, 630 VDC

**PERMISSIBLE AC VOLTAGES (RMS) UP TO 60Hz:**

40 VAC, 160 VAC, 250 VAC

**TEST VOLTAGE (ELECTRODE/ELECTRODE):**

2 x U<sub>R</sub> for 2 sec.

**PULSE RISE TIME:**

$d_v/d_t = 1000 \text{ V}/\mu\text{s}$

**DISSIPATION FACTOR TAN δ**

MEASURED AT	C ≤ 1000pF	C > 1000pF
1kHz	0.3 x 10 <sup>-3</sup>	0.4 x 10 <sup>-3</sup>
10kHz	0.3 x 10 <sup>-3</sup>	0.4 x 10 <sup>-3</sup>
100kHz	0.4 x 10 <sup>-3</sup>	0.8 x 10 <sup>-3</sup>
1 MHz	1 x 10 <sup>-3</sup>	—
Maximum values		

Dimensions in millimeters

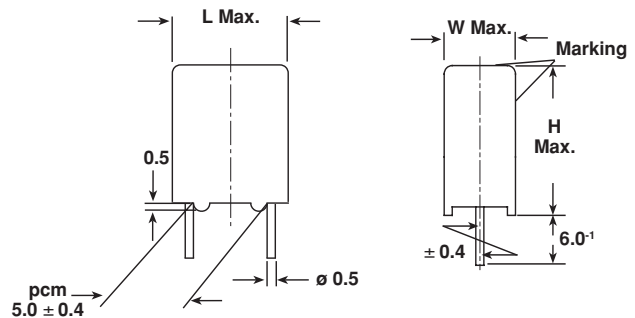
**INSULATION RESISTANCE:**

Measured at 100 VDC (63 VDC series measured at 50 VDC) after one minute  
500,000 MΩ minimum value (1000 GΩ typical value)

**TEMPERATURE COEFFICIENT:**

- 200 x 10<sup>-6</sup>/°C (typical value)

**CAPACITANCE DRIFT:**

Up to + 40°C, ± 0.3% for a period of two years

**DERATING FOR DC AND AC CATEGORY VOLTAGE U<sub>C</sub>:**

At + 85°C: U<sub>C</sub> = 1.0 U<sub>R</sub>  
At + 100°C: U<sub>C</sub> = 0.7 U<sub>R</sub>

**SELF INDUCTANCE:**

~ 6 nH measured with 2mm long leads

**PULL TEST ON LEADS:**

≥ 30 N in direction of leads according to IEC 60068-2-21

**DIELECTRIC ABSORPTION:**

0.05% (typical value) according to IEC 60384-1

**RELIABILITY:**

Operational life > 300,000 h  
Failure rate < 1 FIT (0.5 x U<sub>R</sub> and 40°C)

For further details, please refer to the general information provided in this catalog.

CAPACITANCE	CAPACITANCE CODE	VOLTAGE CODE 06 63 VDC/40 VAC			VOLTAGE CODE 25 250 VDC/160 VAC			VOLTAGE CODE 63 630 VDC/250 VAC		
		W	H	L	W	H	L	W	H	L
100 pF	- 110	—	—	—	—	—	—	4.5	6.0	7.2
150 pF	- 115	—	—	—	—	—	—	4.5	6.0	7.2
220 pF	- 122	—	—	—	—	—	—	4.5	6.0	7.2
330 pF	- 133	—	—	—	—	—	—	4.5	6.0	7.2
470 pF	- 147	—	—	—	—	—	—	4.5	6.0	7.2
680 pF	- 168	—	—	—	—	—	—	4.5	6.0	7.2
1000 pF	- 210	—	—	—	—	—	—	4.5	6.0	7.2
1500 pF	- 215	—	—	—	—	—	—	4.5	6.0	7.2
2200 pF	- 222	—	—	—	4.5	6.0	7.2	5.5	7.0	7.2
3300 pF	- 233	4.5	6.0	7.2	5.5	7.0	7.2	5.5	7.0	7.2
4700 pF	- 247	4.5	6.0	7.2	5.5	7.0	7.2	7.5	9.0	7.2
6800 pF	- 268	4.5	6.0	7.2	7.5	9.0	7.2	7.5	9.0	7.2
0.01 μF	- 310	5.5	7.0	7.2	7.5	9.0	7.2	9.0	10.0	7.2
0.015 μF	- 315	5.5	7.0	7.2	9.0	10.0	7.2	—	—	—
0.022 μF	- 322	7.5	9.0	7.2	—	—	—	—	—	—
0.033 μF	- 333	9.0	10.0	7.2	—	—	—	—	—	—

Further C-values upon request.

**RECOMMENDED PACKAGING**

LETTER CODE	TYPE OF PACKAGING	HEIGHT (H) (mm)	REEL DIAMETER (mm)	ORDERING CODE EXAMPLE	PCM 5
D	AMMO	16.5	S*	KP 1830-310-065-D	X
G	AMMO	18.5	S*	KP 1830-310-065-G	X
F	REEL	16.5	350	KP 1830-310-065-F	X
W	REEL	18.5	350	KP 1830-310-065-W	X
—	BULK	—	—	KP 1830-310-065	X

\*S = box size 55 x 210 x 340mm (W x H x L)

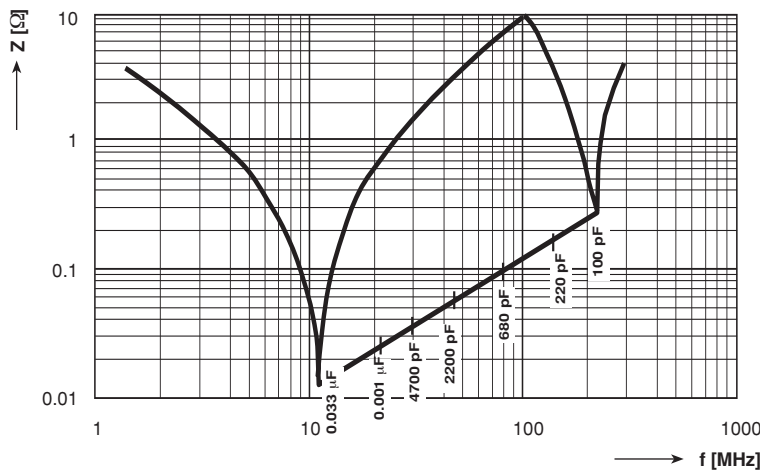

Impedance versus Frequency  $Z = f(f)$  (Lead length 2.0mm)