

# FRD Type : KSF30A60E

OUTLINE DRAWING

## FEATURES

- \* Similar to TO-247AC(TO-3P)Case
- \* Ultra-Fast Recovery
- \* Low Forward Voltage Drop
- \* Low Power Loss,High Efficiency
- \* High Surge Current Capability
- \* 200Volts thru 600Volts Type Available

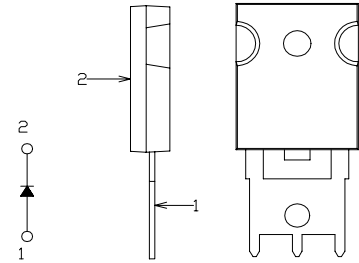

## Maximum Ratings

Approx Net Weight: 6.0g

Rating	Symbol	KSF30A60E			Unit
Repetitive Peak Reverse Voltage	$V_{RRM}$	600			V
Average Rectified Output Current	$I_O$	30	$T_c=64^\circ\text{C}$	50 Hz half Sine Wave Resistive Load	A
RMS Forward Current	$I_{F(RMS)}$	47			A
Surge Forward Current	$I_{FSM}$	400	50Hz Half Sine Wave ,1cycle Non-repetitive		A
Operating JunctionTemperature Range	$T_{jw}$	-40 to +150			$^\circ\text{C}$
Storage Temperature Range	$T_{stg}$	-40 to +150			$^\circ\text{C}$
Mounting torque	$F_{tor}$	recommended torque = 0.5			$\text{N}\cdot\text{m}$

## Electrical • Thermal Characteristics

Characteristics	Symbol	Conditions	Min.	Typ.	Max.	Unit
Peak Reverse Current	$I_{RM}$	$T_j= 25^\circ\text{C}, V_{RM}= V_{RRM}$	-	-	50	$\mu\text{A}$
Peak Forward Voltage	$V_{FM}$	$T_j= 25^\circ\text{C}, I_{FM}= 30 \text{ A}$	-	-	1.7	V
Reverse Recovery Time	trr	$I_{FM}= 10\text{A},$ $-di/dt=50\text{A}/\mu\text{s}, T_a=25^\circ\text{C}$			60	ns
Thermal Resistance	$R_{th(j-c)}$	Junction to Case	-	-	1.4	$^\circ\text{C}/\text{W}$

KSF\_E OUTLINE DRAWING (Dimensions in mm)

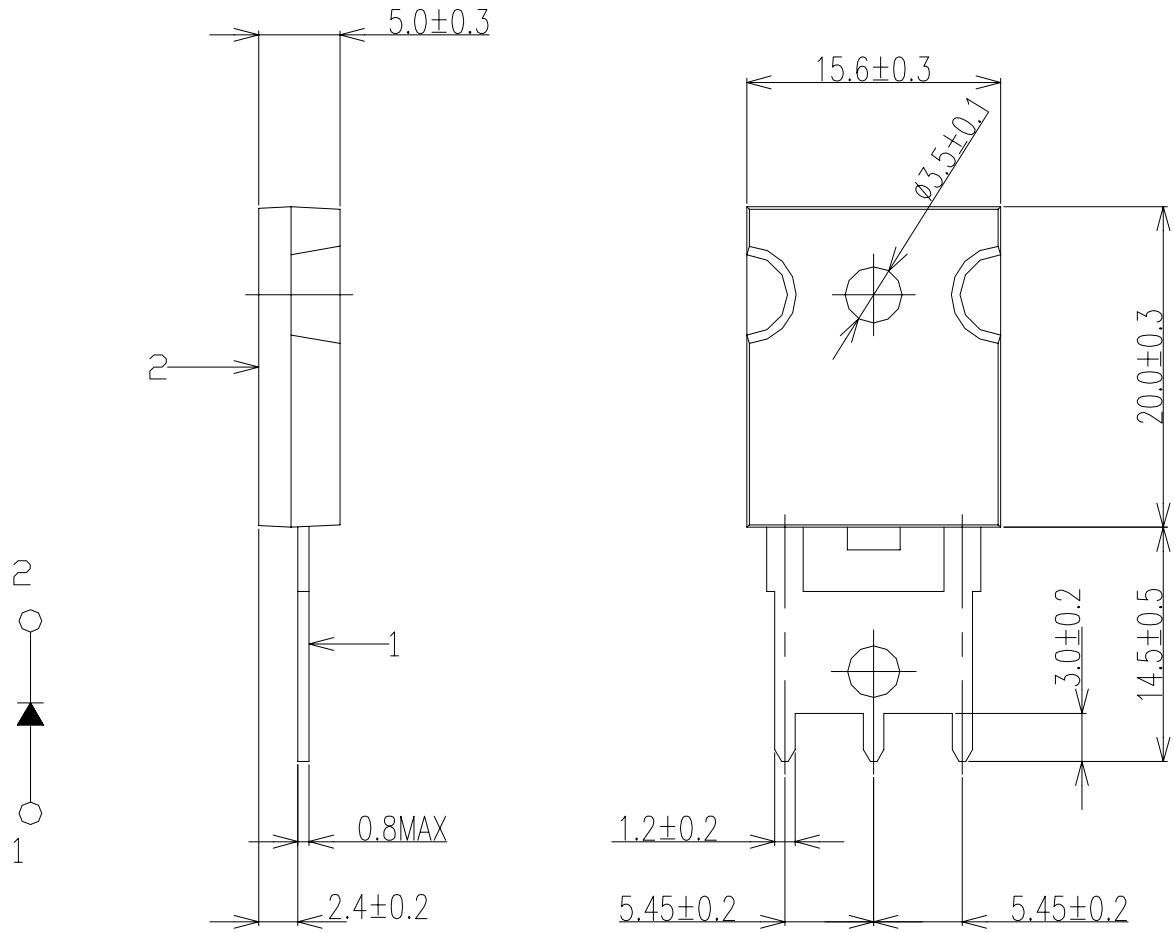

FORWARD CURRENT VS. VOLTAGE

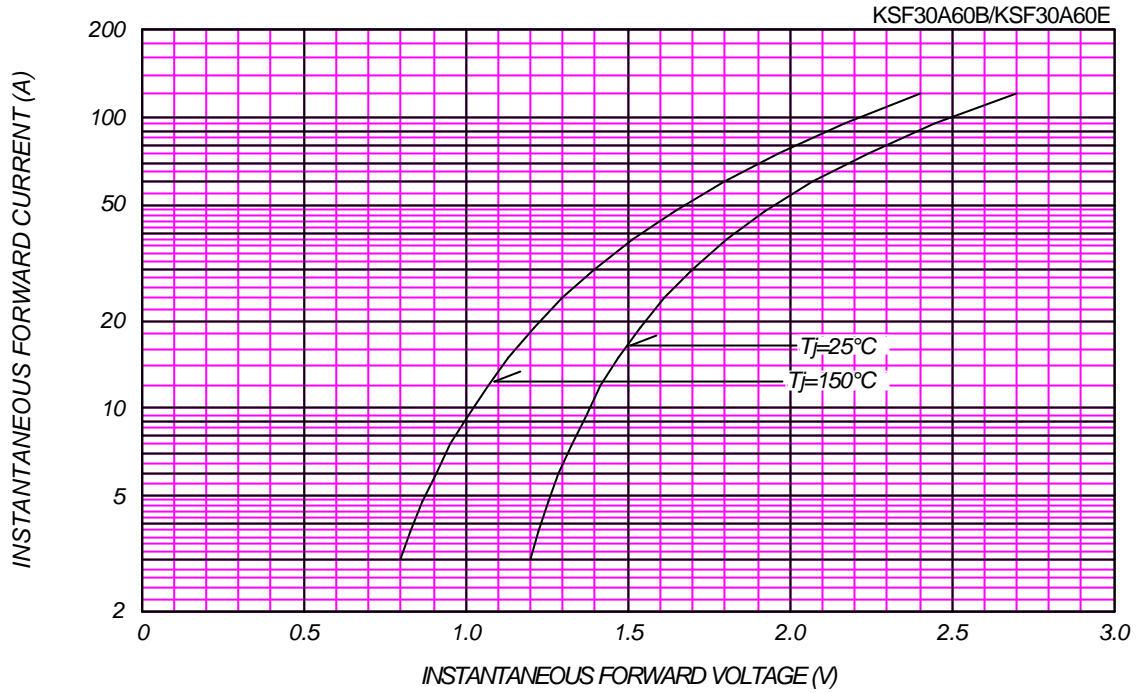

AVERAGE FORWARD POWER DISSIPATION

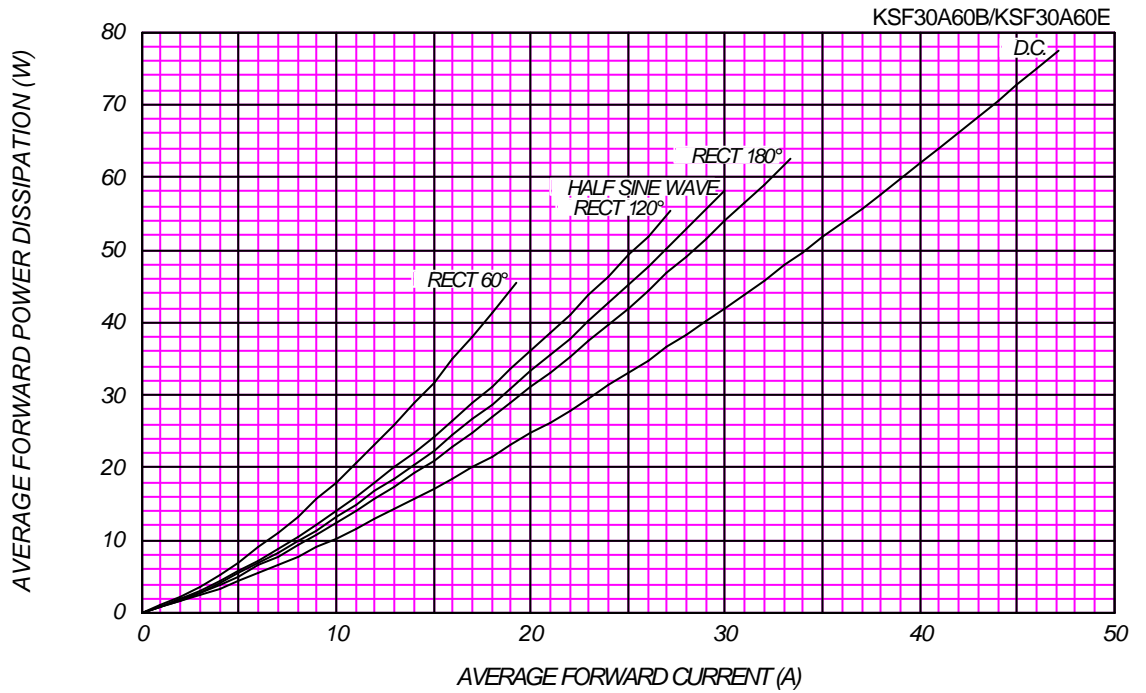



### AVERAGE FORWARD CURRENT VS. CASE TEMPERATURE

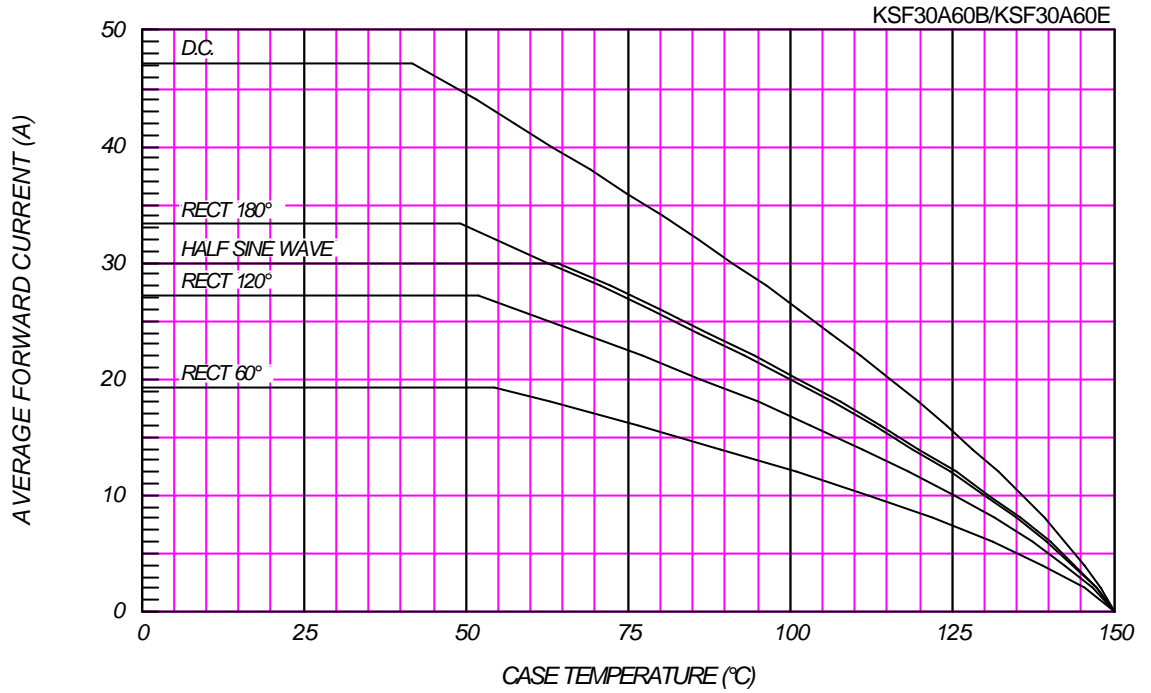

### SURGE CURRENT RATINGS

f=50Hz, Half Sine Wave, Non-Repetitive, No Load

