

L-813SGC SUPER BRIGHT GREEN

### Features

- ULTRA BRIGHTNESS.
- 10mm DIAMETER BIG LAMP.
- WIDE VIEWING ANGLE.
- I.C. COMPATIBLE.
- BOTH DIFFUSED AND WATER CLEAR LENS ARE AVAILABLE.
- RELIABLE AND RUGGED.
- LONG LIFE - SOLID STATE RELIABILITY.

### Description

The Super Bright Green source color devices are made with Gallium Phosphide Green Light Emitting Diode.

### Package Dimensions

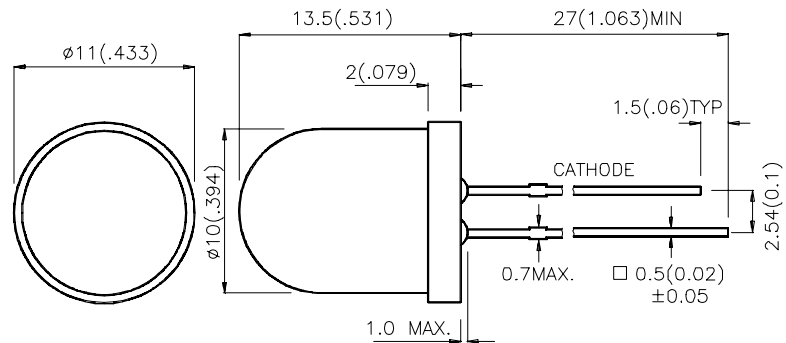

#### Notes:

1. All dimensions are in millimeters (inches).
2. Tolerance is  $\pm 0.25(0.01)$  unless otherwise noted.
3. Lead spacing is measured where the lead emerge package.
4. Specifications are subject to change without notice.

## Selection Guide

Part No.	Dice	Lens Type	Iv (mcd) @ 20 mA		Viewing Angle
			Min.	Typ.	2θ1/2
L-813SGC	SUPER BRIGHT GREEN (GaP)	WATER CLEAR	200	350	40°

Note:

1. θ1/2 is the angle from optical centerline where the luminous intensity is 1/2 the optical centerline value.

## Electrical / Optical Characteristics at T<sub>A</sub>=25°C

Symbol	Parameter	Device	Typ.	Max.	Units	Test Conditions
λ <sub>peak</sub>	Peak Wavelength	Super Bright Green	565		nm	IF=20mA
λ <sub>D</sub>	Dominate Wavelength	Super Bright Green	568		nm	IF=20mA
Δλ <sub>1/2</sub>	Spectral Line Halfwidth	Super Bright Green	30		nm	IF=20mA
C	Capacitance	Super Bright Green	15		pF	VF=0V;f=1MHz
V <sub>F</sub>	Forward Voltage	Super Bright Green	2.2	2.5	V	IF=20mA
I <sub>R</sub>	Reverse Current	Super Bright Green		10	uA	VR = 5V

## Absolute Maximum Ratings at T<sub>A</sub>=25°C

Parameter	Super Bright Green	Units
Power dissipation	105	mW
DC Forward Current	25	mA
Peak Forward Current [1]	140	mA
Reverse Voltage	5	V
Operating/Storage Temperature	-40°C To +85°C	
Lead Solder Temperature [2]	260°C For 5 Seconds	

Notes:

- 1/10 Duty Cycle, 0.1ms Pulse Width.
- 4mm below package base.

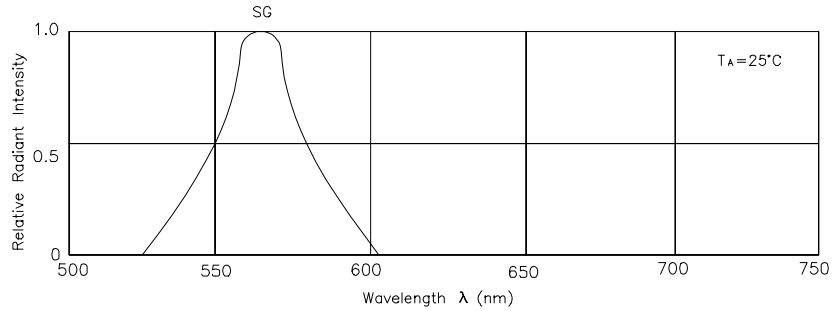

## Super Bright Green L-813SGC

