

### Features

- Extremely Low Parasitic Capacitance and Inductance
- Surface Mountable in Microwave Circuits, No Wirebonds Required
- Rugged HMIC Construction with Polyimide Scratch Protection
- Reliable, Multilayer Metalization with a Diffusion Barrier, 100% Stabilization Bake (300 °C, 16 hours)
- Lower Susceptibility to ESD Damage

### Description

The MA4E2544L-1282 Series SurMount™ Low Barrier, Silicon Schottky Cross-Over Quad Diodes are fabricated with the patented Heterolithic Microwave Integrated Circuit (HMIC) process. HMIC circuits consist of Silicon pedestals which form diodes or via conductors embedded in a glass dielectric, which acts as the low dispersion, low loss, microstrip transmission medium. The combination of silicon and glass allows HMIC devices to have excellent loss and power dissipation characteristics in a low profile, reliable device.

The Surmount Schottky devices are excellent choices for circuits requiring the small parasitics of a beam lead device coupled with the superior mechanical performance of a chip. The SurMount structure employs very low resistance silicon vias to connect the Schottky contacts to the metalized mounting pads on the bottom surface of the chip. These devices are reliable, repeatable, and a lower cost performance solution to conventional devices. They have lower susceptibility to electrostatic discharge than conventional beam lead Schottky diodes.

The multi-layer metalization employed in the fabrication of the Surmount Schottky junctions includes a platinum diffusion barrier, which permits all devices to be subjected to a 16-hour non-operating stabilization bake at 300 °C.

The “ 0505 ” outline allows for Surface Mount placement and multi- functional polarity orientations.

### Applications

The MA4E2544L-1282 Series SurMount™ Low Barrier Silicon Schottky Cross-Over Quad Diodes are recommended for use in microwave circuits through Ku band frequencies for lower power applications such as mixers, sub-harmonic mixers, detectors and limiters. The HMIC construction facilitates the direct replacement of more fragile beam lead diodes with the corresponding Surmount diode, which can be connected to a hard or soft substrate circuit with solder.

### Case Style 1282 - Topview

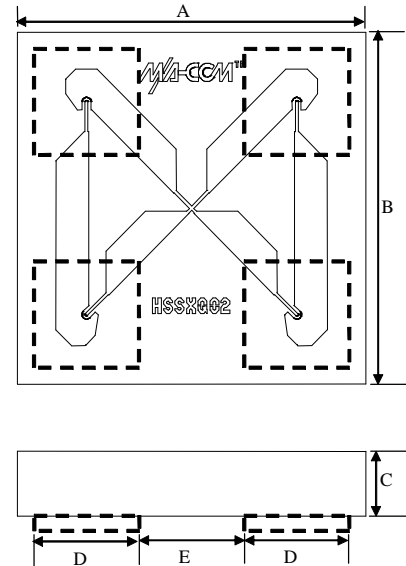

Dim	Inches		Millimeters	
	Min.	Max.	Min.	Max.
A	0.0445	0.0465	1.130	1.180
B	0.0445	0.0465	1.130	1.180
C	0.0040	0.0080	0.102	0.203
D Sq.	0.0128	0.0148	0.325	0.375
E	0.0128	0.0148	0.325	0.375

### Equivalent Circuit

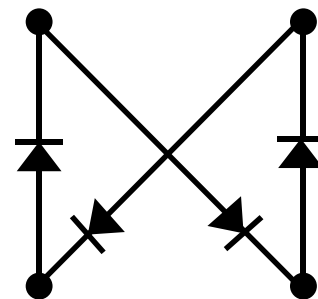

## Electrical Specifications @ 25 °C (Measured as Single Diodes)

Model Number	Type	Recommended Frequency Range	Vf @ 1 mA (mV)	Ct @ 0 V (pF)	Rt Slope Resistance ( Vf1 - Vf2 )/(10.5 mA-9.5 mA ) (W)
MA4E2544L-1282	Low Barrier	DC - 18 GHz	330 Max 300 Typ	0.22 Max 0.15 Typ	16 Typ 20 Max

Rt is the dynamic slope resistance where  
 $R_t = R_s + R_j$ , where  $R_j = 26 / I_{dc}$  ( $I_{dc}$  is in mA) and  $R_s$  is the Ohmic Resistance

Max Forward Voltage Difference  $\Delta V_f$  @ 1 mA: 10 mV

### Handling

All semiconductor chips should be handled with care to avoid damage or contamination from perspiration and skin oils. The use of plastic tipped tweezers or vacuum pickups is strongly recommended for individual components. The top surface of the die has a protective polyimide coating to minimize damage.

The rugged construction of these SurMount devices allows the use of standard handling and die attach techniques. It is important to note that industry standard electrostatic discharge (ESD) control is required at all times, due to the sensitive nature of Schottky junctions.

Bulk handling should insure that abrasion and mechanical shock are minimized.

### Absolute Maximum Ratings<sup>1</sup> @ +25 °C

Parameter	Value
Operating Temperature	-40 °C to +150 °C
Storage Temperature	-40 °C to +150 °C
Junction Temperature	+175 °C
Forward Current	20 mA
Reverse Voltage (10 mA)	5 V
RF C.W. Incident Power	+ 20 dBm
RF & DC Dissipated Power	50 mW

- Exceeding any of these values may result in permanent damage

### Die Bonding

Die attach for these devices is made simple through the use of surface mount die attach technology. Mounting pads are conveniently located on the bottom surface of these devices, and are opposite the active junction. The devices are well suited for higher temperature solder attachment onto hard substrates. 80Au/20Sn and Sn63/Pb37 solders are acceptable for usage.

### Die Attach

For Hard substrates, we recommend utilizing a vacuum tip and force of 60 to 100 grams applied uniformly to the top surface of the device, using a hot gas bonder with equal heat applied across the bottom mounting pads of the device. When soldering to soft substrates, it is recommended to use a lead-tin interface at the circuit board mounting pads. Position the die so that its mounting pads are aligned with the circuit board mounting pads. Reflow the solder paste by applying Equal heat to the circuit at both die-mounting pads. The solder joint must Not be made one at a time, creating un-equal heat flow and thermal stress. Solder reflow should Not be performed by causing heat to flow through the top surface of the die. Since the HMIC glass is transparent, the edges of the mounting pads can be visually inspected through the die after die attach is completed.

**MA4E2544L-1282 Low Barrier SPICE PARAMETERS (per Diode)\***

Is (nA)	Rs (W)	N	Cj0 (pF)	M	Ik (mA)	Cjpar (pF)	Vj (V)	FC	BV (V)	IBV (mA)
26	12.8	1.20	1.0 E-2	0.5	14	9.0 E-2	8.0 E-2	0.5	5.0	1.0 E-2

\* Spice parameters (per Diode) are based on the MA4E2502 Series datasheet.

**Circuit Mounting Dimensions (Inches)**

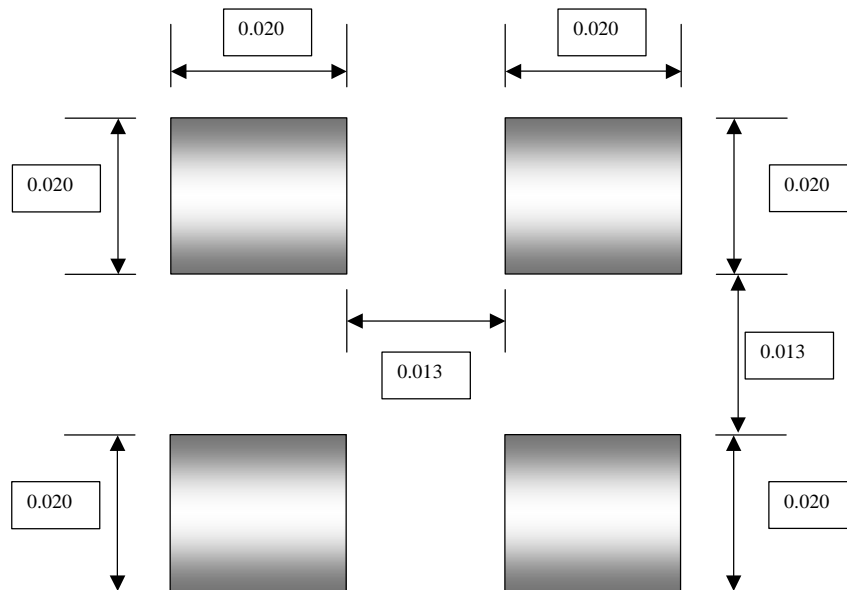

**Ordering Information**

Part Number	Package
MA4E2544L-1282W	Wafer on Frame
MA4E2544L-1282	Die in Carrier
MA4E2544L-1282T	Tape/Reel

## MA4E2544L-1282 Schematic Per Diode

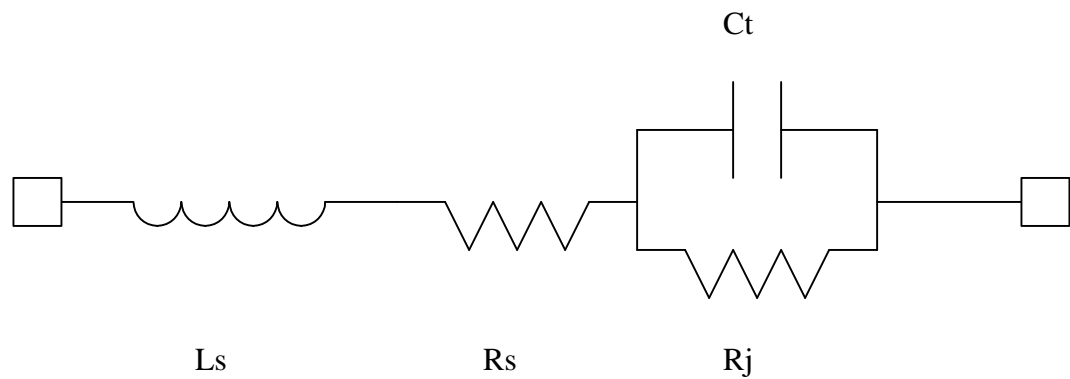

## Average Schematic Values per Diode

Model Number	Ls (nH)	Rs ( W )	Rj ( W )	Ct ( pF )
MA4E2544L-1282	0.2	12.8	26 / Idc	0.15