

The RF TMOS[®] Line Power Field Effect Transistor N-Channel Enhancement Mode

Designed for wideband large-signal amplifier and oscillator applications to 500 MHz.

- Guaranteed 28 Volt, 500 MHz Performance
Output Power = 2.0 Watts
Minimum Gain = 16 dB (Min)
Efficiency = 55% (Typ)
- Facilitates Manual Gain Control, ALC and Modulation Techniques
- 100% Tested for Load Mismatch at All Phase Angles with 30:1 VSWR
- Excellent Thermal Stability, Ideally Suited for Class A Operation

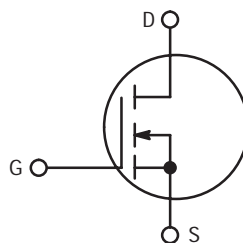

MRF158

To 500 MHz, 2 W, 28 V
TMOS
BROADBAND
RF POWER FET

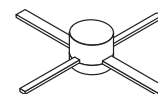

CASE 305A-01, STYLE 2

MAXIMUM RATINGS

Rating	Symbol	Value	Unit
Drain-Source Voltage	V_{DSS}	65	Vdc
Drain-Gate Voltage ($R_{GS} = 1.0 \text{ M}\Omega$)	V_{DGR}	65	Vdc
Gate-Source Voltage	V_{GS}	± 20	Vdc
Drain Current — Continuous	I_D	0.5	Adc
Total Device Dissipation @ $T_C = 25^\circ\text{C}$ Derate above 25°C	P_D	8.0 45	Watts mW/ $^\circ\text{C}$
Storage Temperature Range	T_{stg}	-65 to +150	$^\circ\text{C}$
Operating Junction Temperature	T_J	200	$^\circ\text{C}$

THERMAL CHARACTERISTICS

Characteristic	Symbol	Max	Unit
Thermal Resistance, Junction to Case	$R_{\theta JC}$	13.2	$^\circ\text{C}/\text{W}$

NOTE — **CAUTION** — MOS devices are susceptible to damage from electrostatic charge. Reasonable precautions in handling and packaging MOS devices should be observed.

ELECTRICAL CHARACTERISTICS ($T_C = 25^\circ\text{C}$ unless otherwise noted.)

Characteristic	Symbol	Min	Typ	Max	Unit
----------------	--------	-----	-----	-----	------

OFF CHARACTERISTICS

Drain–Source Breakdown Voltage ($V_{GS} = 0$, $I_D = 1.0$ mA)	$V_{(BR)DSS}$	65	—	—	Vdc
Zero Gate Voltage Drain Current ($V_{DS} = 28$ V, $V_{GS} = 0$)	I_{DSS}	—	—	0.5	mAdc
Gate–Source Leakage Current ($V_{GS} = 20$ V, $V_{DS} = 0$)	I_{GSS}	—	—	1.0	μAdc

ON CHARACTERISTICS

Gate Threshold Voltage ($I_D = 10$ mA, $V_{DS} = 10$ V)	$V_{GS(th)}$	2.0	4.0	5.0	Vdc
Forward Transconductance ($V_{DS} = 10$ V, $I_D = 100$ mA)	g_{fs}	80	110	—	mmhos

DYNAMIC CHARACTERISTICS

Input Capacitance ($V_{DS} = 28$ V, $V_{GS} = 0$, $f = 1.0$ MHz)	C_{iss}	—	3.0	—	pF
Output Capacitance ($V_{DS} = 28$ V, $V_{GS} = 0$, $f = 1.0$ MHz)	C_{oss}	—	4.0	—	pF
Reverse Transfer Capacitance ($V_{DS} = 28$ V, $V_{GS} = 0$, $f = 1.0$ MHz)	C_{rss}	—	0.45	—	pF

FUNCTIONAL CHARACTERISTICS (Figure 1)

Common Source Power Gain ($V_{DD} = 28$ Vdc, $P_{out} = 2.0$ W, $f = 500$ MHz, $I_{DQ} = 25$ mA)	G_{ps}	16	18	—	dB
Drain Efficiency (Figure 1) ($V_{DD} = 28$ Vdc, $P_{out} = 2.0$ W, $f = 500$ MHz, $I_{DQ} = 25$ mA)	η	50	55	—	%
Electrical Ruggedness (Figure 1) ($V_{DD} = 28$ Vdc, $P_{out} = 2.0$ W, $f = 500$ MHz, $I_{DQ} = 25$ mA, VSWR 30:1 at all Phase Angles)	ψ	No Degradation in Output Power			
Series Equivalent Input Impedance ($V_{DD} = 28$ V, $P_{out} = 2.0$ W, $f = 500$ MHz, $I_{DQ} = 25$ mA)	Z_{in}	—	$5.9 - j19.4$	—	Ohms
Series Equivalent Output Impedance ($V_{DD} = 28$ V, $P_{out} = 2.0$ W, $f = 500$ MHz, $I_{DQ} = 25$ mA)	Z_{out}	—	$14.5 - j29$	—	Ohms

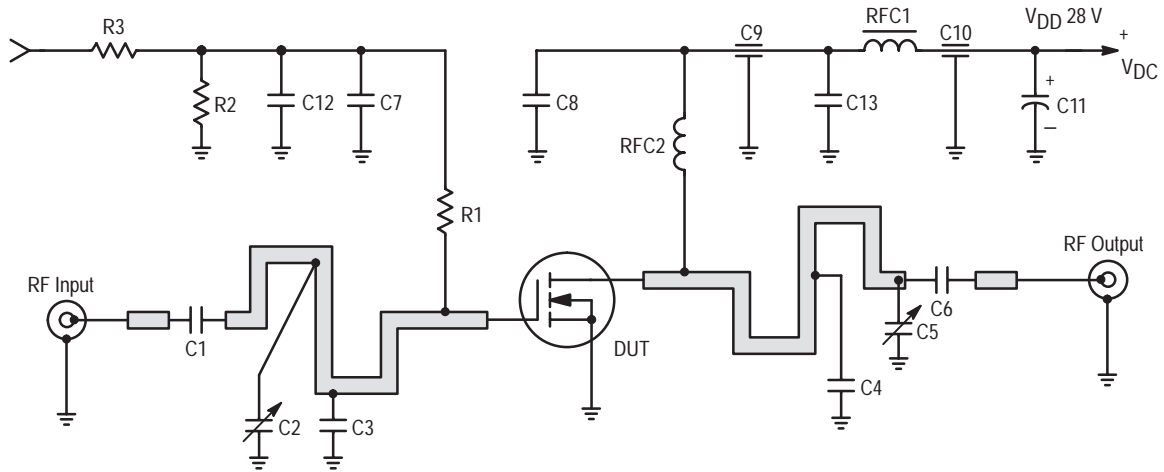

- C1, C6, C12 270 pF, Chip Capacitors
- C2, C5 1–10 pF, Johanson Trimmer Capacitors
- C3 30 pF, 100 mil ATC Chip Capacitor
- C4 3.9 pF, 100 mil ATC Chip Capacitor
- C7, C8 0.1 μ F, Blue Capacitors
- C9, C10 680 pF, Feed Through Capacitors
- C11 50 μ F, 50 V Electrolytic Capacitor
- C13 240 pF, 100 mil ATC Chip Capacitor

- R1 150 Ω , 1/2 Watt
- R2 10 k Ω , 1/2 Watt
- R3 1 k Ω , 1/2 Watt
- RFC1 Ferroxcube VK200–19/4B
- RFC2 8 Turns, #20 AWG, Enameled, ID 110 mils

Board Material — 0.062", Teflon[®] Fiberglass, 1 oz.,
Copper clad both sides, $\epsilon_r = 2.55$

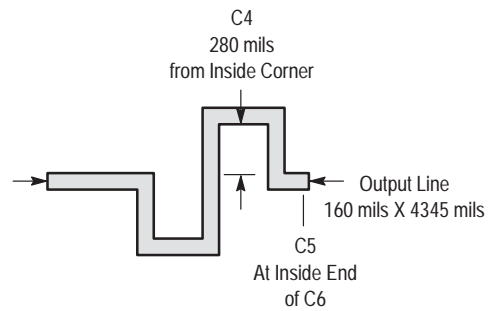
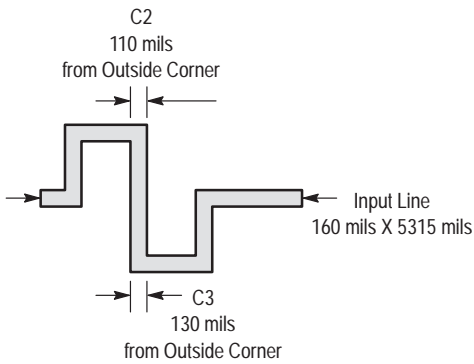

NOTE: Due to variation in Chip Capacitor values and board material, these are approximate positions.

Figure 1. MRF158 500 MHz Test Circuit

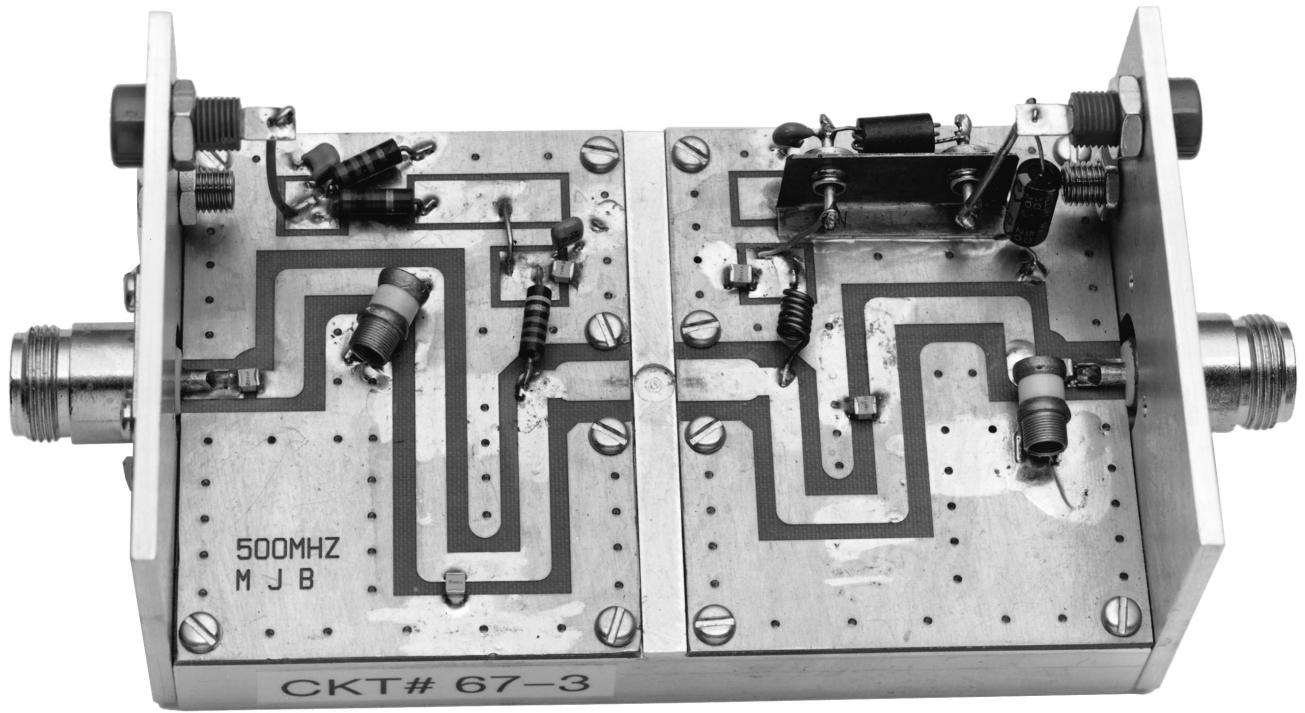

Figure 2. MRF158 Broadband Test Fixture

TYPICAL CHARACTERISTICS

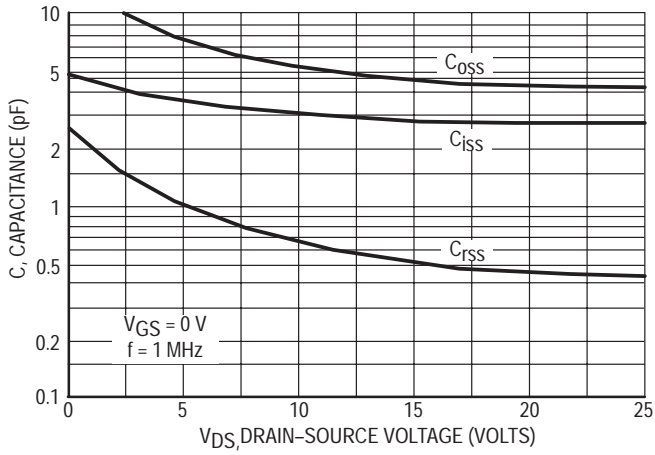

Figure 3. Capacitance versus Drain-Source Voltage

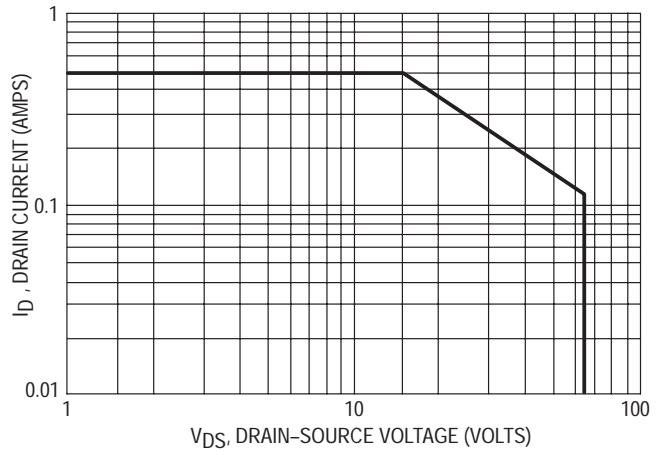

Figure 4. DC Safe Operating Area

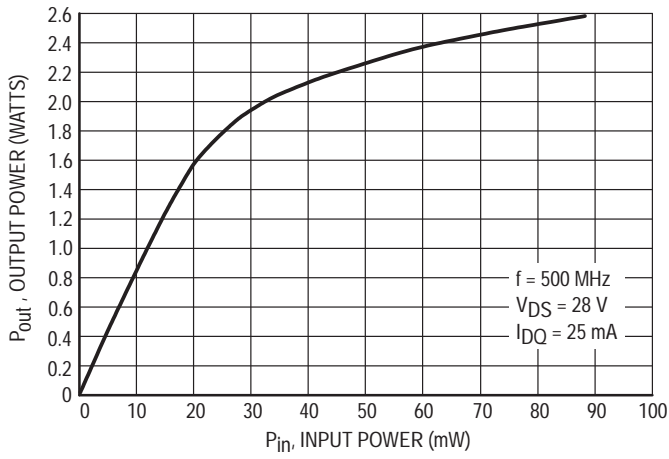

Figure 5. Output Power versus Input Power

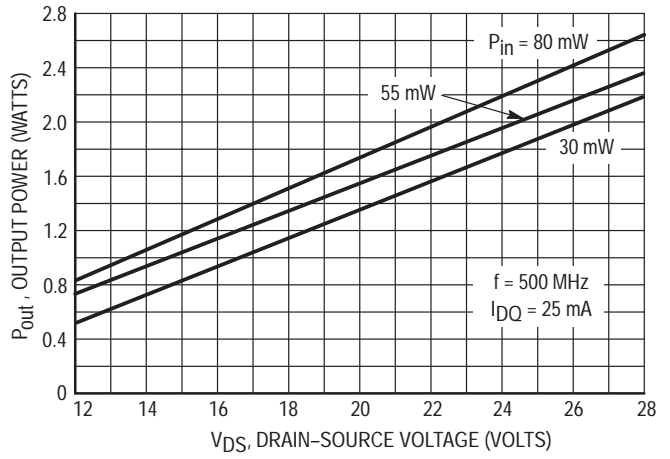

Figure 6. Output Power versus Voltage

Table 1. Common Source S-Parameters ($V_{DS} = 13\text{ V}$, $I_D = 100\text{ mA}$)

f MHz	S11		S21		S12		S22	
	S11	ϕ	S21	ϕ	S12	ϕ	S22	ϕ
5	1.000	-2	9.45	179	0.000	89	0.965	-1
10	0.997	-4	9.45	177	0.005	92	0.969	-3
15	0.999	-5	9.50	176	0.007	86	0.962	-5
20	0.997	-7	9.45	174	0.009	91	0.958	-6
25	0.997	-9	9.44	173	0.012	88	0.958	-7
30	0.996	-10	9.40	172	0.014	82	0.960	-8
35	0.994	-12	9.38	170	0.016	78	0.956	-10
40	0.993	-14	9.35	169	0.016	77	0.958	-11
45	0.990	-15	9.34	167	0.020	79	0.957	-12
50	0.988	-17	9.29	166	0.021	76	0.957	-14
55	0.985	-19	9.25	165	0.023	77	0.955	-15
60	0.983	-21	9.26	163	0.026	75	0.952	-17
65	0.980	-22	9.19	162	0.028	74	0.947	-18
70	0.977	-24	9.15	160	0.029	74	0.943	-20
75	0.973	-25	9.11	159	0.031	74	0.942	-21
80	0.970	-27	9.04	158	0.034	70	0.935	-22
85	0.967	-29	8.98	157	0.035	71	0.932	-24
90	0.963	-30	8.91	155	0.037	67	0.929	-25
95	0.961	-32	8.90	154	0.039	68	0.924	-26
100	0.957	-33	8.81	153	0.040	67	0.917	-27
105	0.953	-35	8.77	151	0.041	64	0.916	-28
109	0.950	-36	8.69	150	0.042	65	0.914	-30
114	0.943	-38	8.62	149	0.045	63	0.906	-31
119	0.940	-40	8.56	148	0.045	62	0.907	-32
124	0.933	-41	8.49	146	0.049	61	0.901	-33
129	0.933	-43	8.46	145	0.049	60	0.901	-35
134	0.923	-44	8.37	144	0.052	59	0.896	-36
139	0.921	-45	8.29	143	0.052	58	0.890	-37
144	0.917	-47	8.22	142	0.055	57	0.885	-39
149	0.913	-48	8.16	140	0.055	55	0.878	-40
154	0.911	-50	8.11	140	0.057	53	0.874	-41
159	0.905	-51	8.02	138	0.059	54	0.868	-42
164	0.902	-52	7.94	137	0.059	53	0.863	-43
169	0.896	-54	7.87	136	0.062	52	0.856	-44
174	0.893	-55	7.79	135	0.063	50	0.851	-45
179	0.890	-56	7.71	134	0.062	50	0.846	-46
184	0.882	-58	7.64	133	0.065	48	0.845	-47
189	0.881	-59	7.59	132	0.065	47	0.840	-48
194	0.874	-60	7.53	131	0.066	47	0.834	-49
199	0.868	-61	7.43	130	0.067	47	0.828	-50
204	0.864	-62	7.36	129	0.068	46	0.829	-51
209	0.861	-63	7.31	128	0.070	45	0.824	-52

Table 1. Common Source S-Parameters ($V_{DS} = 13\text{ V}$, $I_D = 100\text{ mA}$) (continued)

f MHz	S ₁₁		S ₂₁		S ₁₂		S ₂₂	
	S ₁₁	φ	S ₂₁	φ	S ₁₂	φ	S ₂₂	φ
214	0.856	-65	7.24	127	0.070	44	0.820	-53
219	0.853	-66	7.17	126	0.070	43	0.813	-54
224	0.848	-67	7.10	125	0.072	41	0.806	-55
229	0.847	-68	7.02	124	0.074	41	0.803	-56
234	0.841	-69	6.94	124	0.075	40	0.800	-57
239	0.839	-70	6.92	122	0.074	39	0.789	-58
244	0.832	-71	6.80	122	0.076	40	0.783	-59
249	0.828	-72	6.73	121	0.077	38	0.780	-60
254	0.825	-73	6.68	120	0.077	39	0.778	-60
259	0.820	-74	6.60	119	0.078	36	0.772	-61
264	0.816	-75	6.54	118	0.078	35	0.769	-62
269	0.813	-76	6.48	117	0.078	36	0.765	-63
274	0.810	-77	6.42	117	0.079	34	0.765	-64
279	0.806	-78	6.34	116	0.080	35	0.762	-64
284	0.799	-79	6.29	115	0.080	34	0.757	-65
289	0.800	-80	6.23	114	0.081	31	0.756	-66
294	0.795	-81	6.18	113	0.081	33	0.753	-67
299	0.789	-82	6.12	113	0.084	31	0.750	-67
304	0.791	-83	6.07	112	0.082	31	0.742	-68
308	0.790	-84	5.99	111	0.084	30	0.742	-69
313	0.787	-85	5.95	110	0.084	29	0.737	-70
318	0.784	-85	5.88	109	0.083	30	0.729	-70
323	0.779	-86	5.80	109	0.084	28	0.726	-71
328	0.778	-87	5.77	108	0.085	27	0.723	-72
333	0.773	-88	5.69	107	0.085	28	0.720	-72
338	0.771	-89	5.64	107	0.084	26	0.716	-73
343	0.766	-89	5.60	106	0.086	25	0.716	-74
348	0.766	-90	5.55	106	0.086	25	0.712	-74
353	0.763	-91	5.50	105	0.086	24	0.708	-75
358	0.761	-92	5.43	104	0.086	24	0.708	-75
363	0.761	-93	5.41	104	0.086	24	0.706	-76
368	0.755	-94	5.35	103	0.086	23	0.702	-77
373	0.753	-94	5.29	102	0.087	23	0.704	-77
378	0.752	-95	5.25	101	0.086	23	0.700	-78
383	0.750	-96	5.20	101	0.087	22	0.697	-79
388	0.747	-96	5.15	100	0.089	21	0.692	-79
393	0.742	-97	5.08	100	0.087	21	0.693	-80
398	0.741	-98	5.04	99	0.088	20	0.689	-81
403	0.743	-98	5.01	98	0.088	20	0.684	-81
408	0.740	-99	4.97	98	0.088	19	0.682	-81
413	0.734	-100	4.90	97	0.089	19	0.682	-82
418	0.738	-100	4.87	97	0.088	18	0.677	-83

Table 1. Common Source S-Parameters ($V_{DS} = 13\text{ V}$, $I_D = 100\text{ mA}$) (continued)

f MHz	S ₁₁		S ₂₁		S ₁₂		S ₂₂	
	S ₁₁	φ	S ₂₁	φ	S ₁₂	φ	S ₂₂	φ
423	0.733	-101	4.82	96	0.089	18	0.676	-83
428	0.735	-102	4.80	96	0.089	17	0.674	-84
433	0.731	-102	4.74	95	0.088	16	0.672	-84
438	0.732	-103	4.70	94	0.088	17	0.673	-85
443	0.728	-104	4.67	94	0.089	16	0.670	-85
448	0.729	-105	4.64	93	0.090	16	0.671	-86
453	0.727	-105	4.59	93	0.088	16	0.668	-86
458	0.723	-105	4.56	92	0.089	15	0.668	-87
463	0.721	-106	4.50	91	0.088	15	0.668	-87
468	0.720	-107	4.46	91	0.088	15	0.665	-87
473	0.719	-107	4.42	90	0.089	13	0.662	-88
478	0.717	-107	4.38	90	0.089	13	0.662	-89
483	0.717	-108	4.35	89	0.088	13	0.658	-89
488	0.715	-109	4.32	89	0.088	13	0.660	-89
493	0.714	-109	4.28	88	0.090	13	0.655	-90
498	0.714	-110	4.25	88	0.090	12	0.655	-91
503	0.713	-110	4.22	87	0.089	12	0.652	-91
507	0.712	-111	4.17	87	0.090	11	0.650	-91
512	0.711	-111	4.15	86	0.089	11	0.649	-92
517	0.706	-112	4.11	86	0.090	11	0.650	-92
522	0.705	-112	4.07	85	0.089	10	0.650	-93
527	0.706	-113	4.07	85	0.089	10	0.648	-93
532	0.705	-113	4.02	84	0.088	10	0.649	-93
537	0.704	-114	4.00	84	0.088	9	0.645	-94
542	0.704	-114	3.95	83	0.089	9	0.646	-94
547	0.704	-115	3.93	82	0.087	10	0.646	-95
552	0.704	-116	3.90	82	0.090	8	0.645	-95
557	0.702	-116	3.87	82	0.089	8	0.646	-96
562	0.699	-117	3.83	81	0.088	8	0.646	-96
567	0.699	-117	3.80	81	0.089	8	0.641	-96
572	0.700	-117	3.76	80	0.088	7	0.640	-97
577	0.699	-118	3.74	80	0.087	7	0.640	-97
582	0.698	-118	3.70	80	0.088	7	0.641	-98
587	0.699	-118	3.69	79	0.087	7	0.637	-98
592	0.697	-119	3.67	79	0.088	6	0.638	-98
597	0.698	-119	3.64	78	0.088	6	0.633	-99
602	0.698	-119	3.62	78	0.087	6	0.638	-99
607	0.695	-120	3.58	77	0.087	6	0.637	-99
612	0.696	-120	3.57	77	0.087	6	0.637	-100
617	0.694	-121	3.54	76	0.086	5	0.636	-100
622	0.695	-121	3.52	76	0.087	5	0.635	-100
627	0.692	-121	3.48	75	0.088	5	0.637	-101

Table 1. Common Source S-Parameters ($V_{DS} = 13\text{ V}$, $I_D = 100\text{ mA}$) (continued)

f MHz	S11		S21		S12		S22	
	S ₁₁	ϕ	S ₂₁	ϕ	S ₁₂	ϕ	S ₂₂	ϕ
632	0.691	-122	3.46	75	0.085	4	0.634	-101
637	0.691	-122	3.44	74	0.087	4	0.641	-102
642	0.689	-123	3.41	74	0.087	3	0.637	-102
647	0.687	-123	3.38	74	0.087	3	0.634	-103
652	0.689	-124	3.36	73	0.085	3	0.636	-103
657	0.686	-124	3.34	73	0.086	1	0.635	-103
662	0.688	-125	3.30	72	0.086	3	0.634	-104
667	0.689	-125	3.28	72	0.086	2	0.634	-104
672	0.693	-125	3.27	72	0.086	2	0.631	-104
677	0.687	-126	3.24	71	0.086	1	0.632	-104
682	0.689	-126	3.22	71	0.083	1	0.629	-105
687	0.687	-126	3.20	70	0.083	1	0.630	-105
692	0.686	-127	3.17	70	0.083	1	0.630	-105
697	0.690	-127	3.16	70	0.083	0	0.630	-106
702	0.687	-127	3.14	69	0.084	0	0.627	-106
706	0.688	-128	3.12	69	0.083	1	0.630	-106
711	0.685	-128	3.10	68	0.083	0	0.632	-107
716	0.686	-128	3.08	68	0.085	0	0.636	-107
721	0.688	-128	3.08	68	0.084	-1	0.634	-107
726	0.685	-129	3.05	67	0.083	0	0.634	-108
731	0.685	-130	3.02	67	0.083	-1	0.634	-108
736	0.684	-130	3.01	66	0.083	-1	0.635	-108
741	0.680	-130	2.98	66	0.082	-1	0.631	-109
746	0.681	-130	2.97	65	0.083	-2	0.636	-109
751	0.682	-131	2.96	65	0.082	-2	0.631	-110
756	0.683	-131	2.93	65	0.082	-2	0.632	-109
761	0.681	-132	2.90	64	0.082	-1	0.630	-110
766	0.683	-132	2.89	64	0.083	-3	0.632	-110
771	0.684	-132	2.87	64	0.082	-3	0.631	-110
776	0.682	-133	2.85	63	0.081	-4	0.628	-111
781	0.684	-133	2.85	63	0.080	-3	0.630	-111
786	0.686	-133	2.83	63	0.079	-4	0.629	-111
791	0.684	-134	2.81	62	0.080	-3	0.632	-112
796	0.685	-134	2.79	62	0.080	-4	0.631	-112
801	0.683	-134	2.77	62	0.079	-4	0.634	-112
806	0.685	-134	2.75	61	0.079	-2	0.632	-112
811	0.683	-135	2.75	61	0.078	-4	0.635	-113
816	0.684	-135	2.73	60	0.079	-4	0.637	-113
821	0.683	-135	2.70	60	0.077	-3	0.633	-113
826	0.682	-135	2.69	60	0.078	-5	0.637	-114
831	0.682	-136	2.67	59	0.077	-4	0.635	-114
836	0.681	-136	2.66	59	0.077	-5	0.638	-114

Table 1. Common Source S-Parameters ($V_{DS} = 13\text{ V}$, $I_D = 100\text{ mA}$) (continued)

f MHz	S ₁₁		S ₂₁		S ₁₂		S ₂₂	
	S ₁₁	φ	S ₂₁	φ	S ₁₂	φ	S ₂₂	φ
841	0.681	-136	2.64	58	0.079	-4	0.635	-115
846	0.679	-137	2.63	58	0.078	-4	0.637	-115
851	0.678	-137	2.61	58	0.077	-5	0.634	-115
856	0.682	-137	2.59	57	0.077	-5	0.635	-115
861	0.680	-137	2.59	57	0.077	-4	0.634	-115
866	0.681	-138	2.57	57	0.077	-6	0.635	-116
871	0.682	-138	2.55	56	0.075	-6	0.633	-116
876	0.684	-139	2.54	56	0.075	-5	0.631	-116
881	0.683	-139	2.53	56	0.075	-5	0.635	-117
886	0.681	-139	2.52	55	0.074	-6	0.633	-117
891	0.685	-140	2.50	55	0.074	-6	0.633	-117
896	0.683	-140	2.49	55	0.075	-6	0.638	-117
901	0.680	-140	2.47	54	0.073	-5	0.640	-118
905	0.681	-140	2.46	54	0.074	-7	0.637	-118
910	0.684	-140	2.44	54	0.074	-8	0.639	-118
915	0.683	-141	2.43	53	0.073	-6	0.639	-119
920	0.686	-141	2.42	53	0.074	-6	0.643	-119
925	0.683	-141	2.40	53	0.073	-7	0.641	-119
930	0.684	-141	2.39	52	0.072	-7	0.640	-120
935	0.682	-142	2.38	52	0.073	-6	0.638	-120
940	0.685	-142	2.37	52	0.072	-6	0.639	-120
945	0.683	-142	2.36	51	0.072	-7	0.638	-120
950	0.683	-143	2.34	51	0.071	-7	0.639	-120
955	0.683	-143	2.33	51	0.070	-7	0.638	-120
960	0.683	-143	2.32	51	0.073	-8	0.640	-121
965	0.683	-143	2.31	50	0.070	-8	0.640	-121
970	0.684	-144	2.30	50	0.071	-7	0.643	-121
975	0.684	-144	2.28	50	0.069	-8	0.640	-121
980	0.682	-144	2.27	49	0.068	-6	0.641	-122
985	0.685	-144	2.26	49	0.069	-9	0.643	-122
990	0.684	-145	2.25	48	0.067	-8	0.644	-122
995	0.683	-145	2.24	48	0.069	-8	0.644	-123
1000	0.684	-145	2.23	48	0.068	-8	0.643	-123

Table 2. Common Source S-Parameters ($V_{DS} = 28\text{ V}$, $I_D = 100\text{ mA}$)

f MHz	S11		S21		S12		S22	
	S ₁₁	∠	S ₂₁	∠	S ₁₂	∠	S ₂₂	∠
5	1.002	-1	7.98	179	0.001	80	0.966	-1
10	0.999	-3	7.99	178	0.003	105	0.969	-2
15	0.999	-4	8.03	176	0.005	87	0.962	-3
20	0.998	-6	7.99	175	0.007	72	0.959	-4
25	0.999	-7	8.00	174	0.008	82	0.959	-5
30	0.997	-9	7.97	173	0.010	89	0.962	-6
35	0.999	-10	7.95	172	0.012	85	0.961	-7
40	0.996	-12	7.94	170	0.014	74	0.962	-8
45	0.994	-13	7.95	169	0.015	77	0.960	-9
50	0.991	-15	7.91	168	0.017	79	0.959	-10
55	0.990	-16	7.88	167	0.017	83	0.959	-11
60	0.988	-18	7.91	165	0.021	77	0.957	-12
65	0.989	-19	7.85	164	0.020	76	0.957	-13
70	0.983	-20	7.83	163	0.022	74	0.954	-15
75	0.981	-22	7.80	162	0.025	78	0.952	-16
80	0.980	-23	7.76	161	0.026	73	0.948	-17
85	0.979	-25	7.72	160	0.026	72	0.946	-18
90	0.977	-26	7.67	158	0.029	72	0.944	-19
95	0.973	-28	7.68	157	0.030	68	0.939	-19
100	0.970	-29	7.62	156	0.031	68	0.934	-20
105	0.970	-30	7.60	155	0.031	68	0.932	-21
109	0.967	-32	7.54	154	0.034	66	0.931	-22
114	0.961	-33	7.49	153	0.034	67	0.926	-23
119	0.960	-34	7.46	152	0.036	66	0.925	-24
124	0.956	-36	7.42	150	0.038	65	0.923	-25
129	0.954	-37	7.41	149	0.039	65	0.923	-26
134	0.948	-38	7.35	148	0.041	63	0.920	-27
139	0.946	-40	7.29	147	0.042	61	0.916	-28
144	0.944	-41	7.25	146	0.044	61	0.913	-29
149	0.939	-42	7.20	145	0.044	60	0.909	-30
154	0.939	-43	7.17	144	0.046	60	0.904	-31
159	0.935	-45	7.11	143	0.046	58	0.900	-32
164	0.932	-46	7.06	142	0.048	57	0.897	-33
169	0.928	-47	7.01	141	0.049	59	0.891	-34
174	0.927	-48	6.94	140	0.049	55	0.885	-34
179	0.922	-49	6.89	139	0.051	55	0.882	-35
184	0.918	-51	6.85	138	0.052	54	0.883	-36
189	0.915	-52	6.82	137	0.053	53	0.878	-36
194	0.912	-53	6.78	136	0.053	50	0.874	-37
199	0.904	-54	6.71	135	0.054	52	0.867	-38
204	0.902	-55	6.65	134	0.054	51	0.868	-39
209	0.902	-56	6.62	133	0.056	50	0.866	-39

Table 2. Common Source S-Parameters ($V_{DS} = 28\text{ V}$, $I_D = 100\text{ mA}$) (continued)

f MHz	S ₁₁		S ₂₁		S ₁₂		S ₂₂	
	S ₁₁	∠	S ₂₁	∠	S ₁₂	∠	S ₂₂	∠
214	0.898	-58	6.57	132	0.058	50	0.863	-40
219	0.896	-59	6.52	132	0.059	49	0.858	-41
224	0.888	-60	6.47	131	0.059	48	0.850	-42
229	0.887	-61	6.42	130	0.060	46	0.847	-43
234	0.885	-62	6.36	129	0.061	46	0.846	-44
239	0.882	-63	6.35	128	0.062	46	0.837	-45
244	0.876	-64	6.25	127	0.062	45	0.833	-45
249	0.872	-65	6.19	126	0.063	43	0.829	-46
254	0.869	-66	6.15	125	0.064	43	0.828	-47
259	0.867	-67	6.09	125	0.065	43	0.823	-47
264	0.863	-68	6.06	124	0.065	42	0.818	-48
269	0.860	-69	6.01	123	0.065	42	0.816	-48
274	0.856	-70	5.95	122	0.067	41	0.815	-49
279	0.854	-71	5.91	121	0.068	40	0.812	-50
284	0.848	-72	5.87	120	0.068	39	0.809	-50
289	0.849	-73	5.84	120	0.068	38	0.807	-51
294	0.845	-74	5.78	119	0.069	38	0.805	-52
299	0.840	-75	5.73	118	0.070	36	0.800	-53
304	0.839	-75	5.68	117	0.068	37	0.795	-53
308	0.840	-76	5.63	117	0.069	35	0.793	-54
313	0.835	-77	5.59	116	0.071	35	0.790	-55
318	0.832	-78	5.54	115	0.071	35	0.784	-55
323	0.829	-79	5.48	114	0.070	34	0.783	-56
328	0.829	-80	5.45	114	0.072	33	0.778	-56
333	0.825	-81	5.39	113	0.071	33	0.776	-57
338	0.821	-82	5.35	112	0.073	32	0.771	-58
343	0.818	-82	5.31	111	0.072	32	0.770	-58
348	0.816	-83	5.25	111	0.074	30	0.765	-59
353	0.814	-84	5.23	110	0.074	31	0.764	-59
358	0.810	-85	5.18	110	0.073	30	0.764	-59
363	0.810	-85	5.16	109	0.074	30	0.761	-60
368	0.807	-86	5.11	108	0.074	29	0.756	-61
373	0.805	-87	5.07	107	0.075	29	0.760	-61
378	0.801	-88	5.03	107	0.075	27	0.753	-62
383	0.799	-88	4.98	106	0.075	27	0.752	-62
388	0.796	-89	4.94	105	0.074	27	0.748	-63
393	0.796	-90	4.88	105	0.077	26	0.748	-63
398	0.790	-91	4.85	104	0.075	26	0.743	-64
403	0.794	-91	4.82	103	0.076	25	0.739	-64
408	0.789	-92	4.78	103	0.077	26	0.738	-65
413	0.785	-92	4.73	102	0.076	25	0.736	-66
418	0.788	-93	4.70	102	0.076	24	0.732	-66

Table 2. Common Source S-Parameters ($V_{DS} = 28\text{ V}$, $I_D = 100\text{ mA}$) (continued)

f MHz	S ₁₁		S ₂₁		S ₁₂		S ₂₂	
	S ₁₁	φ	S ₂₁	φ	S ₁₂	φ	S ₂₂	φ
423	0.783	-94	4.66	101	0.077	24	0.730	-66
428	0.784	-95	4.64	101	0.079	23	0.728	-67
433	0.779	-95	4.60	100	0.078	23	0.727	-67
438	0.779	-96	4.55	99	0.078	22	0.727	-68
443	0.775	-97	4.52	99	0.077	21	0.725	-68
448	0.778	-98	4.51	98	0.078	21	0.725	-69
453	0.776	-98	4.46	98	0.078	21	0.719	-69
458	0.771	-99	4.43	97	0.078	21	0.720	-70
463	0.771	-99	4.39	96	0.079	20	0.723	-70
468	0.769	-100	4.36	95	0.079	19	0.716	-71
473	0.767	-100	4.31	95	0.079	18	0.716	-71
478	0.765	-101	4.28	95	0.078	20	0.716	-72
483	0.764	-101	4.24	94	0.079	19	0.710	-72
488	0.763	-102	4.22	94	0.079	19	0.711	-72
493	0.762	-103	4.18	93	0.079	18	0.709	-73
498	0.760	-103	4.15	93	0.080	17	0.706	-73
503	0.760	-104	4.12	92	0.079	16	0.705	-74
507	0.758	-104	4.10	91	0.079	17	0.701	-74
512	0.758	-105	4.08	91	0.079	16	0.700	-74
517	0.751	-105	4.03	90	0.078	16	0.700	-75
522	0.750	-106	4.00	90	0.080	15	0.700	-75
527	0.753	-106	4.00	89	0.079	16	0.698	-76
532	0.750	-107	3.96	89	0.079	14	0.699	-76
537	0.749	-107	3.94	88	0.079	15	0.696	-76
542	0.748	-108	3.90	87	0.080	13	0.696	-77
547	0.749	-109	3.88	87	0.080	13	0.697	-77
552	0.750	-109	3.85	87	0.079	14	0.693	-78
557	0.747	-110	3.82	86	0.078	13	0.697	-78
562	0.743	-110	3.78	86	0.079	12	0.695	-79
567	0.744	-111	3.75	85	0.079	12	0.689	-79
572	0.742	-111	3.73	85	0.078	11	0.690	-79
577	0.743	-112	3.70	84	0.080	12	0.689	-80
582	0.743	-112	3.67	84	0.080	11	0.691	-80
587	0.742	-112	3.64	83	0.078	11	0.688	-80
592	0.740	-113	3.62	83	0.080	10	0.685	-81
597	0.741	-113	3.61	82	0.078	10	0.682	-81
602	0.739	-114	3.59	82	0.078	10	0.685	-82
607	0.736	-114	3.56	82	0.079	9	0.682	-82
612	0.737	-115	3.53	81	0.077	9	0.684	-82
617	0.735	-115	3.52	81	0.078	10	0.682	-82
622	0.736	-115	3.50	80	0.078	9	0.680	-83
627	0.732	-116	3.47	80	0.078	8	0.681	-83

Table 2. Common Source S-Parameters ($V_{DS} = 28\text{ V}$, $I_D = 100\text{ mA}$) (continued)

f MHz	S ₁₁		S ₂₁		S ₁₂		S ₂₂	
	S ₁₁	φ	S ₂₁	φ	S ₁₂	φ	S ₂₂	φ
632	0.733	-117	3.45	79	0.077	8	0.682	-84
637	0.730	-117	3.41	79	0.078	8	0.684	-84
642	0.731	-117	3.40	78	0.077	8	0.683	-85
647	0.728	-118	3.37	78	0.077	7	0.679	-85
652	0.730	-118	3.35	77	0.077	8	0.679	-85
657	0.725	-119	3.32	77	0.077	7	0.679	-85
662	0.725	-119	3.29	76	0.079	6	0.679	-86
667	0.727	-120	3.27	76	0.078	5	0.677	-86
672	0.731	-120	3.26	75	0.077	6	0.676	-86
677	0.727	-120	3.24	75	0.077	5	0.675	-87
682	0.725	-121	3.21	75	0.077	4	0.673	-87
687	0.726	-121	3.19	74	0.078	6	0.672	-87
692	0.724	-121	3.17	74	0.076	6	0.672	-88
697	0.728	-122	3.17	74	0.075	6	0.672	-88
702	0.724	-122	3.13	73	0.075	5	0.672	-88
706	0.724	-122	3.12	73	0.077	5	0.670	-89
711	0.722	-123	3.10	72	0.077	5	0.674	-89
716	0.722	-123	3.09	72	0.076	4	0.676	-89
721	0.723	-124	3.08	71	0.075	2	0.674	-90
726	0.720	-124	3.05	71	0.075	4	0.672	-90
731	0.719	-124	3.03	70	0.075	4	0.676	-90
736	0.720	-125	3.02	70	0.076	3	0.675	-91
741	0.716	-125	2.99	70	0.075	2	0.672	-91
746	0.718	-126	2.98	69	0.075	3	0.677	-91
751	0.715	-126	2.97	69	0.075	3	0.670	-92
756	0.717	-126	2.94	68	0.075	3	0.673	-92
761	0.716	-127	2.92	68	0.075	2	0.668	-92
766	0.717	-127	2.90	67	0.075	2	0.673	-93
771	0.717	-128	2.88	67	0.073	2	0.669	-93
776	0.714	-128	2.86	67	0.076	1	0.668	-93
781	0.718	-128	2.86	66	0.074	1	0.668	-93
786	0.718	-129	2.85	66	0.073	1	0.670	-94
791	0.718	-129	2.82	66	0.073	1	0.670	-94
796	0.716	-129	2.81	65	0.072	0	0.668	-94
801	0.715	-130	2.79	65	0.073	-1	0.671	-95
806	0.718	-130	2.77	65	0.071	1	0.669	-95
811	0.714	-130	2.77	64	0.072	0	0.672	-95
816	0.714	-130	2.74	64	0.072	0	0.673	-96
821	0.714	-131	2.72	63	0.070	0	0.671	-96
826	0.715	-131	2.71	63	0.073	0	0.675	-96
831	0.713	-131	2.69	63	0.071	0	0.672	-96
836	0.713	-131	2.68	62	0.072	-1	0.672	-97

Table 2. Common Source S-Parameters ($V_{DS} = 28\text{ V}$, $I_D = 100\text{ mA}$) (continued)

f MHz	S ₁₁		S ₂₁		S ₁₂		S ₂₂	
	S ₁₁	∠	S ₂₁	∠	S ₁₂	∠	S ₂₂	∠
841	0.712	-132	2.67	62	0.069	0	0.671	-97
846	0.710	-132	2.65	61	0.071	-1	0.672	-97
851	0.708	-132	2.63	61	0.071	-1	0.670	-97
856	0.712	-133	2.62	61	0.071	-2	0.669	-98
861	0.710	-133	2.61	61	0.071	-2	0.669	-98
866	0.710	-134	2.59	60	0.071	-2	0.669	-98
871	0.710	-134	2.58	60	0.071	-2	0.669	-98
876	0.713	-134	2.57	59	0.069	-3	0.666	-99
881	0.711	-135	2.56	59	0.068	-3	0.667	-99
886	0.710	-135	2.54	59	0.069	-3	0.666	-99
891	0.711	-135	2.52	58	0.067	-3	0.668	-100
896	0.711	-136	2.52	58	0.070	-2	0.670	-100
901	0.709	-136	2.50	57	0.069	-5	0.669	-101
905	0.711	-136	2.49	57	0.069	-3	0.671	-101
910	0.711	-136	2.47	57	0.068	-4	0.674	-101
915	0.710	-137	2.46	56	0.068	-2	0.673	-101
920	0.712	-137	2.45	56	0.066	-4	0.673	-102
925	0.708	-137	2.42	56	0.067	-4	0.673	-102
930	0.709	-137	2.42	55	0.068	-3	0.673	-102
935	0.709	-138	2.41	55	0.066	-4	0.670	-102
940	0.709	-138	2.40	55	0.066	-2	0.672	-102
945	0.709	-138	2.39	54	0.065	-3	0.672	-103
950	0.708	-139	2.38	54	0.066	-4	0.671	-103
955	0.711	-139	2.36	54	0.065	-5	0.669	-103
960	0.709	-139	2.35	54	0.064	-4	0.672	-103
965	0.708	-140	2.34	53	0.064	-3	0.671	-104
970	0.707	-140	2.33	53	0.065	-5	0.673	-104
975	0.706	-140	2.32	52	0.065	-4	0.671	-104
980	0.707	-140	2.30	52	0.065	-4	0.669	-104
985	0.707	-140	2.29	51	0.064	-6	0.674	-105
990	0.708	-141	2.28	51	0.063	-4	0.674	-105
995	0.708	-141	2.28	51	0.063	-5	0.674	-105
1000	0.710	-141	2.26	50	0.063	-5	0.676	-106

PACKAGE DIMENSIONS

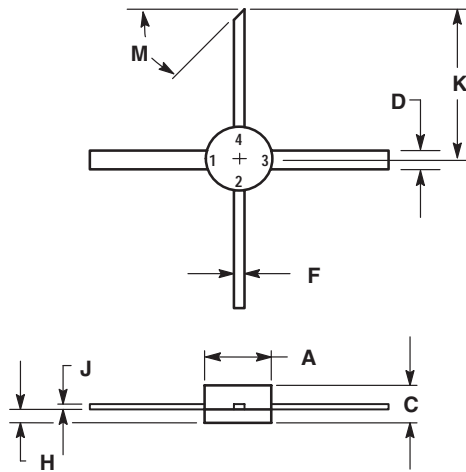

NOTES:

1. DIMENSIONING AND TOLERANCING PER ANSI Y14.5M, 1982.
2. CONTROLLING DIMENSION: INCH.

DIM	INCHES		MILLIMETERS	
	MIN	MAX	MIN	MAX
A	0.200	0.220	5.08	5.59
C	0.095	0.130	2.41	3.30
D	0.055	0.065	1.40	1.65
F	0.025	0.035	0.64	0.89
H	0.040	0.050	1.02	1.27
J	0.003	0.007	0.08	0.18
K	0.435	----	11.05	----
M	45 °REF		45 °REF	

STYLE 2:

- PIN 1. SOURCE
- GATE
- SOURCE
- DRAIN

**CASE 305A-01
ISSUE A**

Specifications subject to change without notice.

- **North America:** Tel. (800) 366-2266, Fax (800) 618-8883
- **Asia/Pacific:** Tel.+81-44-844-8296, Fax +81-44-844-8298
- **Europe:** Tel. +44 (1344) 869 595, Fax+44 (1344) 300 020

Visit www.macom.com for additional data sheets and product information.

REV 9

tyco / Electronics

MACOM