

The RF Small Signal Line NPN Silicon High-Frequency Transistor

Designed for low noise, wide dynamic range front end amplifiers at frequencies to 1.5 GHz. Specifically aimed at portable communication devices such as pagers and hand-held phones.

- Low Noise Figure
NF = 1.5 dB (Typ) @ 1.0 GHz
- High Current Gain-Bandwidth Product ($f_T = 7.0$ GHz Typ @ 6.0 V, 40 mA)
- Small, Surface-Mount Package (SC-70/SOT-323)
- Available in Tape and Reel Packaging.
T1 Suffix = 3,000 Units per 8 mm, 7 inch Reel.

MRF577T1

**LOW NOISE
HIGH FREQUENCY
TRANSISTOR**



**CASE 419-02, STYLE 3
(SC-70/SOT-323)**

MAXIMUM RATINGS

Rating	Symbol	Value	Unit
Collector-Emitter Voltage	V_{CEO}	10	Vdc
Collector-Base Voltage	V_{CBO}	20	Vdc
Emitter-Base Voltage	V_{EBO}	3.0	Vdc
Collector Current — Continuous	I_C	80	mAdc
Total Device Dissipation @ $T_C = 75^\circ\text{C}$ (1) Derate above 75°C	P_D	232 3.1	mW mW/ $^\circ\text{C}$
Storage Temperature Range	T_{stg}	- 55 to +150	$^\circ\text{C}$
Operating Temperature Range	T_J	150	$^\circ\text{C}$

THERMAL CHARACTERISTICS

Characteristic	Symbol	Value	Unit
Thermal Resistance, Junction-to-Case (1)	$R_{\theta JC}$	323	$^\circ\text{C}/\text{W}$

DEVICE MARKING

MRF577T1 = D

(1) Case temperature measured on the collector lead immediately adjacent to body of package.

ELECTRICAL CHARACTERISTICS ($T_C = 25^\circ\text{C}$ unless otherwise noted)

Characteristic	Symbol	Min	Typ	Max	Unit
OFF CHARACTERISTICS					
Collector–Emitter Breakdown Voltage ($I_C = 1.0\text{ mA}$, $I_B = 0\text{ mA}$)	$V_{(BR)CEO}$	10	12	—	Vdc
Collector–Base Breakdown Voltage ($I_C = 0.1\text{ mA}$, $I_E = 0$)	$V_{(BR)CBO}$	20	—	—	Vdc
Emitter–Base Breakdown Voltage ($I_E = 50\text{ }\mu\text{A}$, $I_C = 0$)	$V_{(BR)EBO}$	2.5	—	—	Vdc
Collector Cutoff Current ($V_{CB} = 8.0\text{ Vdc}$, $I_E = 0$)	I_{CBO}	—	—	10	μA

ON CHARACTERISTICS

DC Current Gain ($V_{CE} = 10\text{ Vdc}$, $I_C = 30\text{ mA}$)	h_{FE}	50	—	300	—
--	----------	----	---	-----	---

DYNAMIC CHARACTERISTICS

Collector–Base Capacitance ($V_{CB} = 6.0\text{ Vdc}$, $I_E = 0$, $f = 1.0\text{ MHz}$)	C_{cb}	—	0.85	—	pF
Current–Gain Bandwidth Product ($V_{CE} = 6.0\text{ Vdc}$, $I_E = 40\text{ mA}$, $f = 1.0\text{ GHz}$)	f_τ	—	7.0	—	GHz

PERFORMANCE CHARACTERISTICS

Noise Figure — Minimum ($V_{CE} = 6.0\text{ Vdc}$, $I_C = 5.0\text{ mA}$) Figure 1	500 MHz 1.0 GHz	N_{Fmin}	— —	1.0 1.5	— —	dB
Associated Gain at Minimum Noise Figure ($V_{CE} = 6.0\text{ Vdc}$, $I_C = 5.0\text{ mA}$) Figure 1	500 MHz 1.0 GHz	G_{NF}	— —	15 10	— —	dB
Maximum Unilateral Gain ($V_{CE} = 6.0\text{ Vdc}$, $I_C = 40\text{ mA}$, $f = 1000\text{ MHz}$)		G_{Umax}	—	12	—	dB
Insertion Gain ($V_{CE} = 6.0\text{ Vdc}$, $I_C = 40\text{ mA}$, $f = 1000\text{ MHz}$)		$ S_{21} ^2$	—	11	—	dB
Noise Resistance ($V_{CE} = 6.0\text{ Vdc}$, $I_C = 5.0\text{ mA}$, $f = 1000\text{ MHz}$)		R_N	—	6.0	—	Ohms

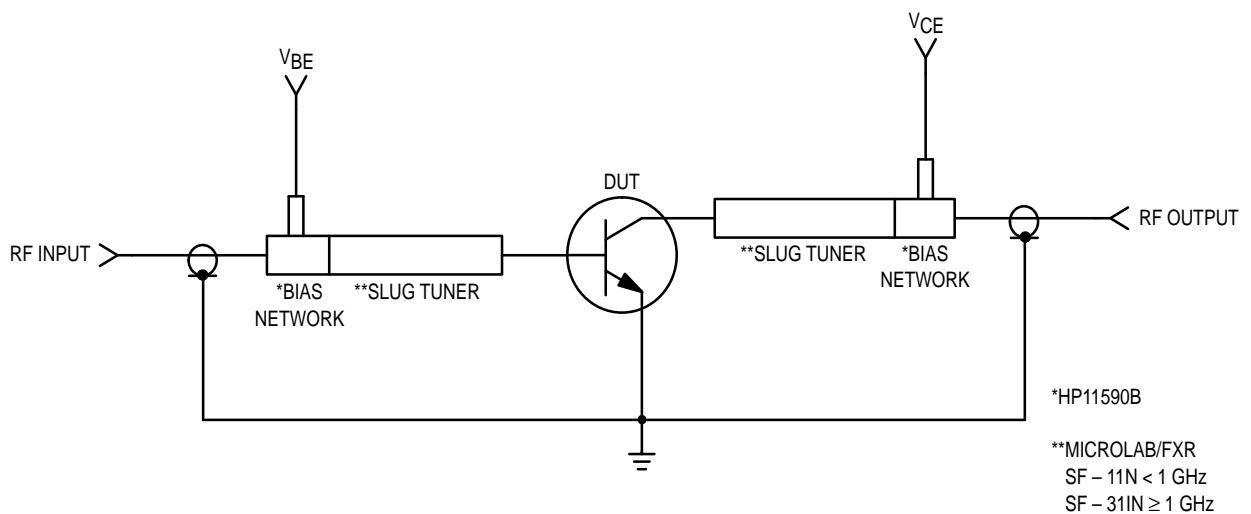

Figure 1. Functional Circuit Schematic

TYPICAL CHARACTERISTICS

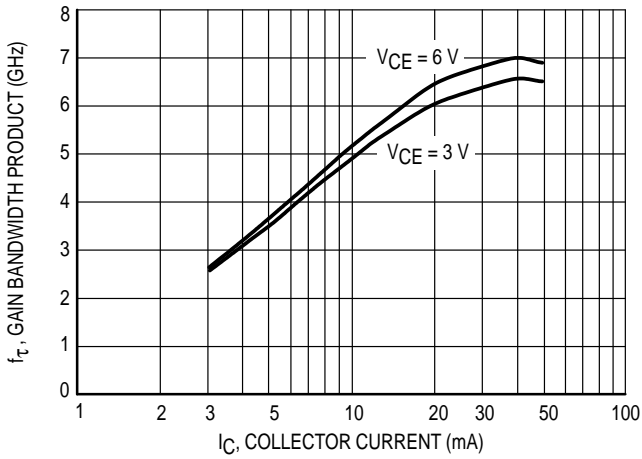

Figure 2. f_T , Current-Gain Bandwidth Product versus Collector Current

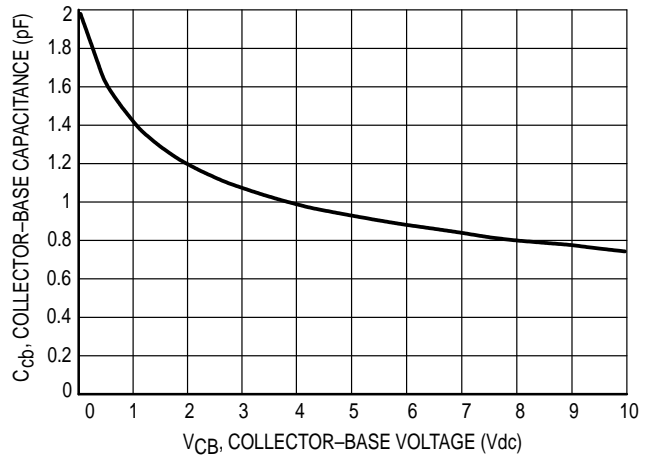

Figure 3. Collector-Base Capacitance versus Voltage

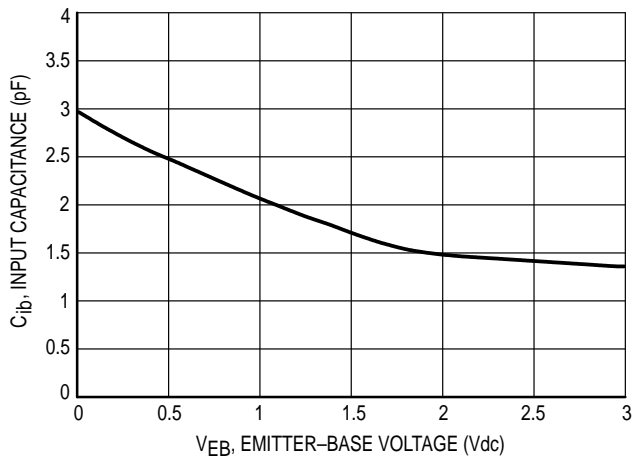

Figure 4. Input Capacitance versus Emitter-Base Voltage

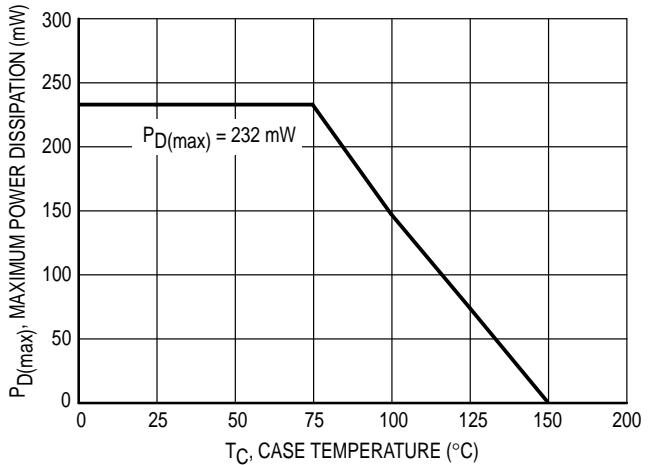

Figure 5. Maximum Power Dissipation versus Collector Lead Temperature (T_C)

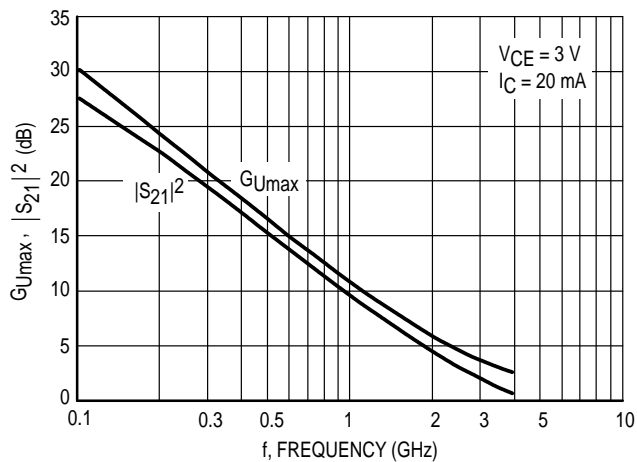

Figure 6. Forward Insertion Gain and Maximum Unilateral Gain versus Frequency

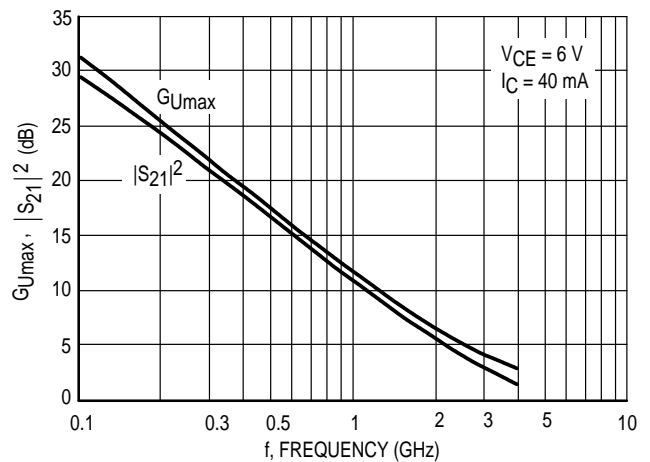

Figure 7. Forward Insertion Gain and Maximum Unilateral Gain versus Frequency

TYPICAL CHARACTERISTICS

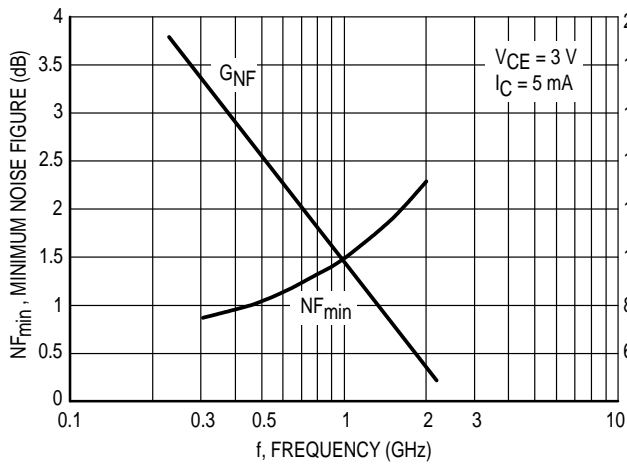

Figure 8. Minimum Noise Figure and Associated Gain versus Frequency

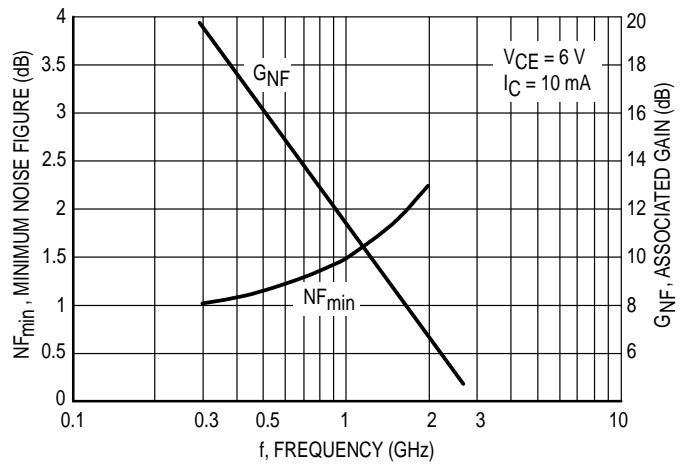

Figure 9. Minimum Noise Figure and Associated Gain versus Frequency

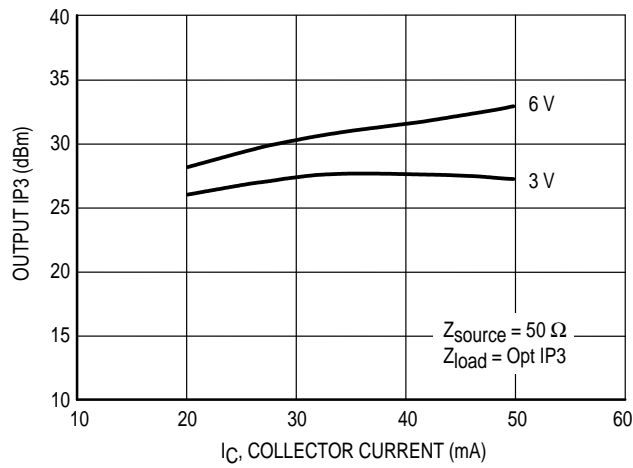

Figure 10. Output Third Order Intercept Point versus Collector Current

VCE (Volts)	I _C (mA)	f (MHz)	NF _{min} (dB)	Γ _o	∠Γ _o	R _N	
3.0	3.0	300	0.81	0.44	57	10	
		500	1.05	0.43	88	9	
		900	1.51	0.46	138	6	
		1000	1.62	0.47	149	6	
		1500	2.11	0.56	-173	4	
		2000	2.55	0.69	-157	6	
		5.0	300	0.86	0.33	58	8
	500	1.03	0.34	88	8		
	900	1.40	0.40	139	6		
	1000	1.50	0.42	149	5		
	1500	1.89	0.52	-173	4		
	2000	2.29	0.65	-157	6		
	6.0	3.0	300	0.81	0.45	50	11
			500	1.07	0.44	81	11
900			1.56	0.44	132	8	
1000			1.70	0.45	142	7	
1500			2.23	0.53	-177	5	
2000			2.72	0.67	-158	6	
5.0			300	0.85	0.37	50	10
500		1.04	0.37	80	9		
900		1.42	0.39	130	7		
1000		1.52	0.40	141	6		
1500		2.00	0.50	-179	5		
2000		2.43	0.65	-159	6		
10		300	1.02	0.24	52	9	
500		1.15	0.26	82	9		
900		1.42	0.33	131	7		
1000		1.50	0.35	142	6		
1500		1.85	0.47	-179	5		
2000		2.25	0.61	-159	5		

Table 1. MRF577T1 Common Emitter Noise Parameters

VCE (Volts)	IC (mA)	f (GHz)	S11		S21		S12		S22		
			S11	∠φ	S21	∠φ	S12	∠φ	S22	∠φ	
3.0	3.0	0.10	0.852	-47	9.09	149	0.061	65	0.881	-25	
		0.20	0.758	-84	7.13	126	0.095	49	0.708	-41	
		0.30	0.687	-108	5.60	112	0.112	41	0.575	-50	
		0.40	0.649	-125	4.52	101	0.121	37	0.490	-56	
		0.50	0.622	-138	3.79	93	0.127	35	0.434	-60	
		0.60	0.588	-148	3.20	87	0.131	35	0.384	-60	
		0.70	0.581	-157	2.81	82	0.135	3	0.357	-63	
		0.80	0.580	-164	2.48	77	0.140	35	0.342	-65	
		0.90	0.574	-170	2.25	72	0.144	37	0.325	-68	
		1.00	0.572	-175	2.05	68	0.149	38	0.315	-70	
		1.50	0.578	163	1.46	50	0.183	45	0.297	-86	
		2.00	0.591	146	1.16	36	0.233	49	0.308	-103	
	2.50	0.609	131	0.99	25	0.298	49	0.330	-122		
	3.00	0.617	118	0.87	17	0.374	45	0.351	-140		
	4.00	0.643	94	0.75	5	0.519	32	0.406	-176		
	5.0	5.0	0.10	0.770	-60	13.16	141	0.055	61	0.807	-35
			0.20	0.666	-99	9.41	119	0.080	47	0.587	-54
			0.30	0.607	-123	7.02	106	0.092	43	0.450	-64
			0.40	0.580	-138	5.52	97	0.101	42	0.371	-70
			0.50	0.562	-149	4.54	90	0.109	42	0.322	-75
			0.60	0.536	-159	3.83	85	0.117	44	0.273	-75
			0.70	0.533	-166	3.33	80	0.124	45	0.249	-78
			0.80	0.534	-172	2.94	76	0.133	46	0.235	-81
			0.90	0.531	-177	2.65	71	0.142	47	0.222	-84
			1.00	0.530	178	2.41	68	0.152	48	0.213	-87
			1.50	0.539	159	1.71	52	0.204	50	0.199	-102
			2.00	0.551	144	1.36	38	0.262	49	0.212	-119
	2.50	0.568	130	1.15	27	0.324	46	0.237	-136		
	3.00	0.578	118	1.02	18	0.390	42	0.260	-152		
	4.00	0.614	96	0.86	3	0.513	29	0.326	177		
	10	10	0.10	0.629	-83	19.46	130	0.044	56	0.663	-53
			0.20	0.551	-123	12.13	109	0.060	49	0.426	-75
			0.30	0.522	-143	8.57	98	0.072	50	0.315	-88
			0.40	0.513	-155	6.58	91	0.083	52	0.259	-97
			0.50	0.505	-163	5.35	86	0.096	54	0.227	-103
			0.60	0.489	-171	4.50	82	0.108	56	0.183	-108
0.70			0.490	-177	3.89	78	0.121	57	0.168	-113	
0.80			0.492	178	3.43	74	0.134	57	0.159	-118	
0.90			0.491	174	3.08	71	0.148	58	0.152	-122	
1.00			0.491	170	2.80	68	0.161	58	0.148	-127	
1.50			0.501	154	1.96	53	0.228	55	0.147	-144	
2.00			0.513	140	1.56	40	0.293	50	0.163	-156	
2.50	0.528	127	1.32	30	0.354	44	0.190	-168			
3.00	0.536	116	1.17	20	0.414	38	0.209	-179			
4.00	0.578	96	0.99	4	0.516	25	0.270	159			
20	20	0.10	0.509	-111	24.53	119	0.034	56	0.513	-72	
		0.20	0.485	-144	13.84	102	0.048	58	0.319	-99	
		0.30	0.478	-159	9.51	93	0.062	61	0.249	-115	
		0.40	0.478	-167	7.22	88	0.077	63	0.220	-125	
		0.50	0.476	-173	5.84	83	0.093	64	0.203	-133	
		0.60	0.466	179	4.90	80	0.108	65	0.173	-142	
		0.70	0.469	175	4.23	76	0.124	65	0.168	-147	
		0.80	0.471	171	3.73	73	0.139	64	0.166	-152	
		0.90	0.472	168	3.34	70	0.155	64	0.164	-157	
		1.00	0.472	165	3.03	67	0.170	63	0.164	-160	
		1.50	0.482	150	2.12	54	0.244	57	0.171	-174	
		2.00	0.493	138	1.68	42	0.313	50	0.188	177	
2.50	0.507	125	1.42	32	0.375	44	0.211	168			
3.00	0.514	115	1.26	22	0.432	36	0.226	159			
4.00	0.555	96	1.06	6	0.525	23	0.274	143			

Table 2. Common Emitter S-Parameters

VCE (Volts)	IC (mA)	f (GHz)	S11		S21		S12		S22		
			S11	∠φ	S21	∠φ	S12	∠φ	S22	∠φ	
3.0	40	0.10	0.457	-136	27.07	111	0.027	61	0.401	-90	
		0.20	0.465	-159	14.51	97	0.042	66	0.268	-119	
		0.30	0.467	-169	9.85	90	0.059	69	0.230	-135	
		0.40	0.471	-175	7.44	85	0.076	70	0.217	-144	
		0.50	0.470	-180	6.00	82	0.093	70	0.209	-151	
		0.60	0.464	174	5.04	79	0.110	70	0.189	-160	
		0.70	0.467	170	4.34	75	0.127	69	0.188	-164	
		0.80	0.469	167	3.83	72	0.143	68	0.189	-168	
		0.90	0.469	164	3.42	70	0.159	67	0.189	-171	
		1.00	0.470	161	3.11	67	0.176	65	0.191	-174	
		1.50	0.480	148	2.17	54	0.253	58	0.200	174	
		2.00	0.490	136	1.71	42	0.323	51	0.215	166	
		2.50	0.504	124	1.45	32	0.386	43	0.237	159	
3.00	0.510	114	1.29	23	0.443	36	0.249	150			
4.00	0.549	95	1.09	6	0.532	22	0.291	136			
6.0	3.0	0.10	0.872	-42	9.23	151	0.049	68	0.903	-20	
		0.20	0.776	-76	7.48	130	0.079	53	0.757	-33	
		0.30	0.695	-100	6.01	115	0.095	45	0.635	-40	
		0.40	0.647	-117	4.91	105	0.104	40	0.555	-45	
		0.50	0.612	-131	4.14	97	0.110	38	0.500	-47	
		0.60	0.572	-141	3.51	90	0.114	38	0.454	-47	
		0.70	0.56	-151	3.09	85	0.118	38	0.427	-49	
		0.80	0.558	-158	2.72	80	0.123	38	0.412	-50	
		0.90	0.549	-165	2.48	75	0.127	40	0.395	-52	
		1.00	0.544	-171	2.26	71	0.132	42	0.384	-54	
		1.50	0.548	167	1.60	53	0.163	49	0.360	-66	
		2.00	0.562	149	1.27	39	0.209	54	0.360	-82	
		2.50	0.581	133	1.06	27	0.271	54	0.366	-99	
	3.00	0.593	120	0.93	18	0.346	51	0.375	-117		
	4.00	0.628	96	0.77	6	0.498	38	0.405	-155		
		5.0	0.10	0.797	-52	13.58	145	0.045	64	0.840	-28
			0.20	0.678	-89	10.10	122	0.068	51	0.642	-43
			0.30	0.601	-113	7.68	109	0.080	46	0.509	-50
			0.40	0.562	-130	6.10	100	0.089	45	0.430	-54
			0.50	0.537	-141	5.05	93	0.096	45	0.380	-56
			0.60	0.505	-152	4.25	87	0.103	46	0.335	-55
			0.70	0.499	-160	3.71	82	0.110	47	0.311	-56
			0.80	0.498	-166	3.27	78	0.118	48	0.296	-58
			0.90	0.492	-172	2.95	74	0.127	50	0.282	-59
			1.00	0.49	-177	2.68	70	0.135	51	0.272	-61
			1.50	0.498	163	1.89	54	0.183	53	0.249	-72
			2.00	0.512	147	1.49	40	0.237	53	0.249	-87
			2.50	0.533	132	1.25	29	0.295	51	0.256	-105
		3.00	0.547	120	1.10	19	0.359	46	0.266	-121	
		4.00	0.594	98	0.90	4	0.488	34	0.309	-158	
		10	0.100	0.658	-71	20.57	134	0.038	60	0.710	-42
			0.200	0.542	-111	13.36	112	0.053	52	0.473	-58
			0.300	0.492	-132	9.57	101	0.065	52	0.353	-65
	0.400		0.472	-146	7.39	94	0.075	54	0.288	-70	
	0.500		0.46	-155	6.02	88	0.086	56	0.250	-72	
	0.600		0.438	-164	5.06	84	0.097	58	0.207	-70	
	0.700		0.437	-171	4.38	80	0.109	59	0.189	-72	
	0.800		0.438	-176	3.86	76	0.120	59	0.176	-74	
	0.900		0.437	179	3.46	73	0.132	59	0.166	-76	
	1.000		0.437	175	3.14	69	0.144	59	0.158	-78	
	1.500		0.448	158	2.19	55	0.205	57	0.140	-91	
	2.000		0.463	144	1.73	42	0.265	53	0.143	-107	
	2.500		0.482	130	1.45	31	0.323	48	0.155	-126	
	3.000	0.496	119	1.28	21	0.381	42	0.165	-141		
	4.000	0.549	99	1.05	5	0.488	30	0.216	-173		

Table 2. Common Emitter S-Parameters (continued)

V _{CE} (Volts)	I _C (mA)	f (GHz)	S ₁₁		S ₂₁		S ₁₂		S ₂₂	
			S ₁₁	∠φ	S ₂₁	∠φ	S ₁₂	∠φ	S ₂₂	∠φ
6.0	20	0.10	0.521	-94	26.70	123	0.030	59	0.555	-56
		0.20	0.448	-131	15.53	104	0.043	58	0.335	-74
		0.30	0.426	-149	10.76	96	0.056	62	0.243	-82
		0.40	0.42	-159	8.19	90	0.070	64	0.199	-88
		0.50	0.415	-166	6.63	85	0.083	65	0.172	-92
		0.60	0.401	-175	5.56	82	0.097	66	0.132	-93
		0.70	0.403	-180	4.80	78	0.111	66	0.121	-96
		0.80	0.405	176	4.23	75	0.125	65	0.112	-100
		0.90	0.405	173	3.78	72	0.139	65	0.106	-104
		1.00	0.406	169	3.43	69	0.153	64	0.101	-107
		1.50	0.42	154	2.38	56	0.220	59	0.094	-125
		2.00	0.434	141	1.87	44	0.284	53	0.105	-141
		2.50	0.454	128	1.57	33	0.343	47	0.125	-157
		3.00	0.466	118	1.39	23	0.399	40	0.137	-169
	4.00	0.52	99	1.15	6	0.495	28	0.189	167	
	40	0.10	0.438	-116	30.08	114	0.025	61	0.423	-68
		0.20	0.407	-147	16.43	99	0.039	65	0.245	-86
		0.30	0.400	-160	11.20	92	0.053	68	0.179	-96
		0.40	0.400	-168	8.48	87	0.068	70	0.152	-103
		0.50	0.398	-173	6.84	83	0.083	70	0.135	-108
		0.60	0.389	179	5.74	80	0.098	70	0.100	-113
		0.70	0.392	175	4.95	77	0.113	69	0.094	-117
		0.80	0.395	172	4.35	74	0.128	69	0.090	-123
		0.90	0.396	169	3.89	71	0.143	68	0.087	-127
		1.00	0.397	165	3.53	68	0.157	67	0.085	-131
		1.50	0.411	152	2.44	55	0.227	60	0.088	-149
		2.00	0.426	139	1.92	44	0.293	53	0.103	-161
		2.50	0.446	127	1.61	33	0.352	47	0.126	-173
3.00		0.459	117	1.42	24	0.408	40	0.139	176	
4.00	0.512	99	1.17	7	0.500	27	0.190	156		

Table 2. Common Emitter S-Parameters (continued)

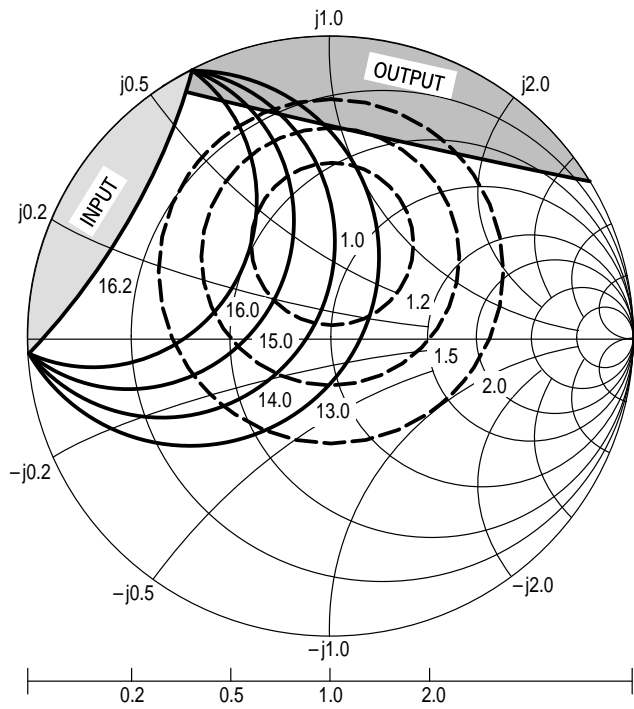

$V_{CE} = 3.0 \text{ V}$
 $I_C = 5.0 \text{ mA}$
 □ — Potentially Unstable

f (MHz)	NF OPT (dB)	Γ_{MS} NF OPT	R_N	K
500	1.03	$0.34 \angle 88^\circ$	8	0.69

Figure 11. MRF577T1 Constant Gain and Noise Figure Contours

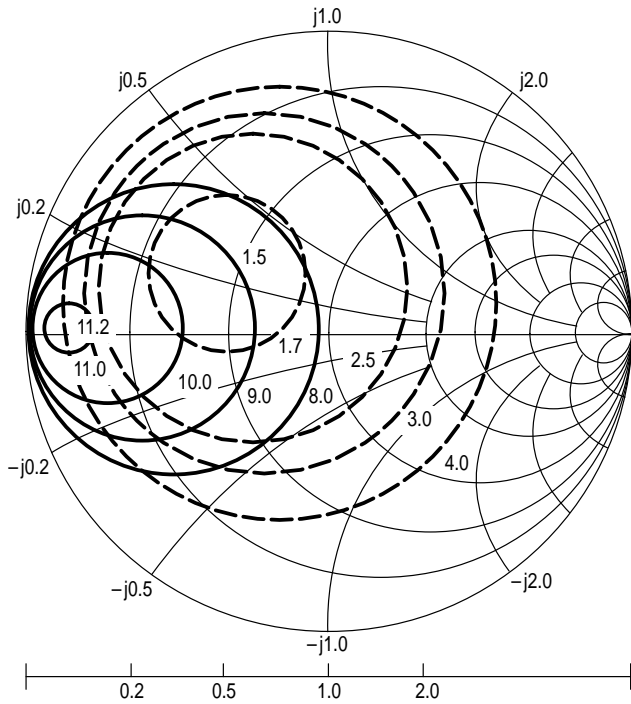

$V_{CE} = 3.0 \text{ V}$
 $I_C = 5.0 \text{ mA}$

f (MHz)	NF OPT (dB)	Γ_{MS} NF OPT	R_N	K
1000	1.47	$0.42 \angle 149^\circ$	5	1.02

Figure 12. MRF577T1 Constant Gain and Noise Figure Contours

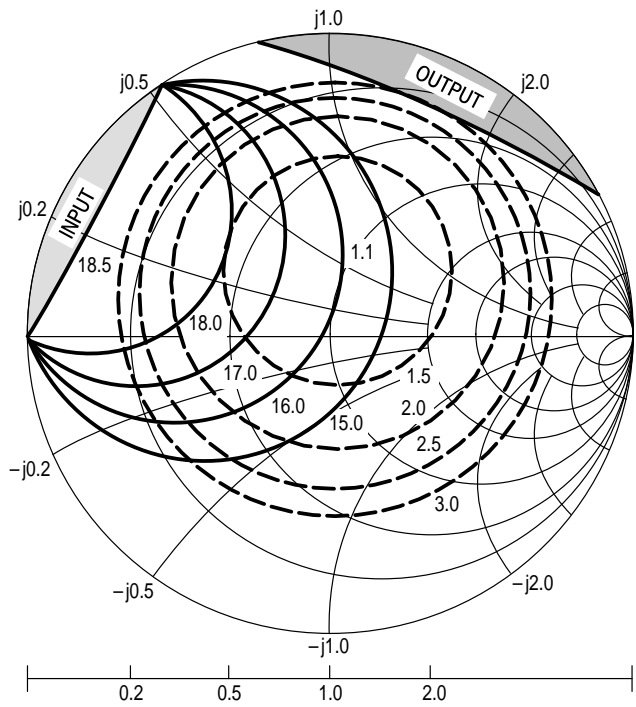

$V_{CE} = 6.0 \text{ V}$
 $I_C = 10 \text{ mA}$
 □ — Potentially Unstable

f (MHz)	NF OPT (dB)	Γ_{MS} NF OPT	R_N	K
500	1.15	$0.26 \angle 82^\circ$	9	0.86

Figure 13. MRF577T1 Constant Gain and Noise Figure Contours

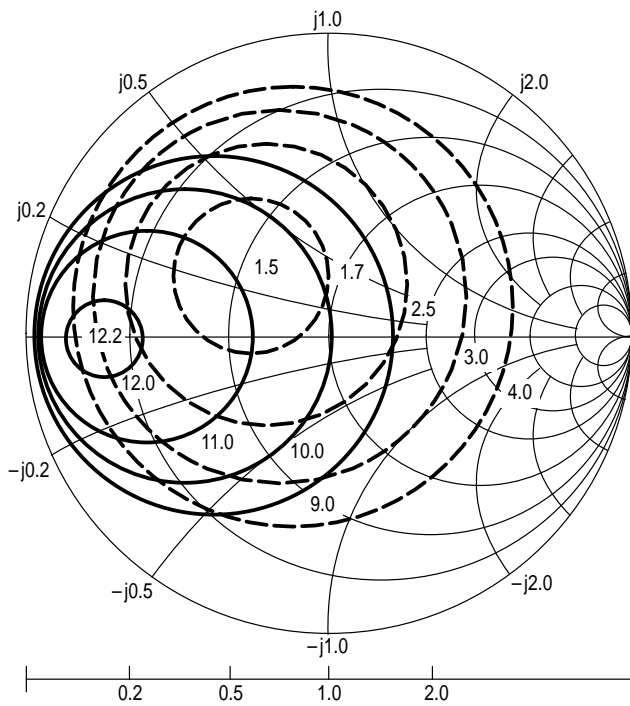

$V_{CE} = 6.0 \text{ V}$
 $I_C = 10 \text{ mA}$

f (MHz)	NF OPT (dB)	Γ_{MS} NF OPT	R_N	K
1000	1.49	$0.35 \angle 142^\circ$	6	1.04

Figure 14. MRF577T1 Constant Gain and Noise Figure Contours

PACKAGE DIMENSIONS

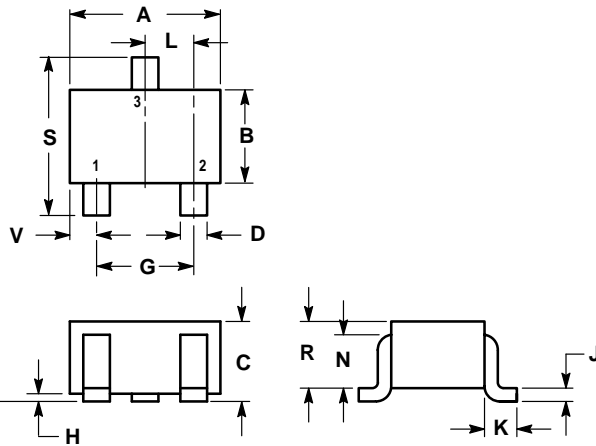

- NOTES:
 1. DIMENSIONING AND TOLERANCING PER ANSI Y14.5M, 1982.
 2. CONTROLLING DIMENSION: INCH.

DIM	INCHES		MILLIMETERS	
	MIN	MAX	MIN	MAX
A	0.071	0.087	1.80	2.20
B	0.045	0.053	1.15	1.35
C	0.035	0.049	0.90	1.25
D	0.012	0.016	0.30	0.40
G	0.047	0.055	1.20	1.40
H	0.000	0.004	0.00	0.10
J	0.004	0.010	0.10	0.25
K	0.017 REF		0.425 REF	
L	0.026 BSC		0.650 BSC	
N	0.028 REF		0.700 REF	
R	0.031	0.039	0.80	1.00
S	0.079	0.087	2.00	2.20
V	0.012	0.016	0.30	0.40

STYLE 3:
 PIN 1. BASE
 2. EMITTER
 3. COLLECTOR

CASE 419-02
 ISSUE J

Motorola reserves the right to make changes without further notice to any products herein. Motorola makes no warranty, representation or guarantee regarding the suitability of its products for any particular purpose, nor does Motorola assume any liability arising out of the application or use of any product or circuit, and specifically disclaims any and all liability, including without limitation consequential or incidental damages. "Typical" parameters which may be provided in Motorola data sheets and/or specifications can and do vary in different applications and actual performance may vary over time. All operating parameters, including "Typicals" must be validated for each customer application by customer's technical experts. Motorola does not convey any license under its patent rights nor the rights of others. Motorola products are not designed, intended, or authorized for use as components in systems intended for surgical implant into the body, or other applications intended to support or sustain life, or for any other application in which the failure of the Motorola product could create a situation where personal injury or death may occur. Should Buyer purchase or use Motorola products for any such unintended or unauthorized application, Buyer shall indemnify and hold Motorola and its officers, employees, subsidiaries, affiliates, and distributors harmless against all claims, costs, damages, and expenses, and reasonable attorney fees arising out of, directly or indirectly, any claim of personal injury or death associated with such unintended or unauthorized use, even if such claim alleges that Motorola was negligent regarding the design or manufacture of the part. Motorola and  are registered trademarks of Motorola, Inc. Motorola, Inc. is an Equal Opportunity/Affirmative Action Employer.

Mfax is a trademark of Motorola, Inc.

How to reach us:

USA/EUROPE/Locations Not Listed: Motorola Literature Distribution;
P.O. Box 5405, Denver, Colorado 80217. 1-303-675-2140 or 1-800-441-2447

JAPAN: Nippon Motorola Ltd.: SPD, Strategic Planning Office, 141,
4-32-1 Nishi-Gotanda, Shagawa-ku, Tokyo, Japan. 03-5487-8488

Customer Focus Center: 1-800-521-6274

Mfax™: RMFAX0@email.sps.mot.com – TOUCHTONE 1-602-244-6609
Motorola Fax Back System – US & Canada ONLY 1-800-774-1848
– http://sps.motorola.com/mfax/

ASIA/PACIFIC: Motorola Semiconductors H.K. Ltd.; 8B Tai Ping Industrial Park,
51 Ting Kok Road, Tai Po, N.T., Hong Kong. 852-26629298

HOME PAGE: <http://motorola.com/sps/>



MOTOROLA



MRF577T1/D