

3.5 Amp Bi-polar stepper motor drive

MSE570

The MSE570 is a low cost high performance Eurocard Bi-polar drive designed for mounting in 3U high Euro-racks. Ideally suited for use with Nema size 23 & 34 stepper motors, the unit provides a wide range of current options. Designed for use by original equipment manufacturers, the unit provides a reliable and economic in-service proven' drive solution. Furthermore, the MSE570 design enables users to customise the unit to meet their exact requirements by providing a series of upgrade options which can easily be implemented.

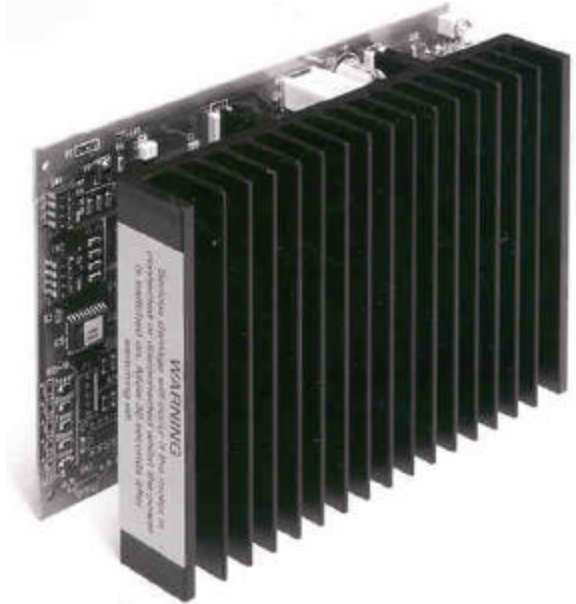

Efficient chopped constant current drive

The MSE570 features a chopped constant current output stage with on-board current settings from 0.5 to 3.5 Amps per phase to meet the requirements of virtually any 2 or 4 phase hybrid stepper motor in the Nema 17, 23 & 34 frame sizes. The use of chopped constant current drive techniques eliminate power consuming series resistors normally associated with low cost drives. Furthermore, the output current may be reduced via an external input when the motor is at standstill to reduce temperature rise in the drive and the motor. The drive is designed for use with rail voltages from 24 to 35 Vdc such as MSE173 when up to 4 drives can be incorporated in a single rack together with the power supply. For high speed operation the 35 Vdc Power supply type MSE562 is recommended for single and dual axis applications depending on motor current settings.

Choice of full or half step drive

The MSE570 may be set to operate in full step or half step drive. Half step drive is recommended since it provides increased resolution (400 steps/rev. using conventional hybrid stepper motors) together with improved smoothness and damping of motor resonance.

Customising the MSE 570 to meet individual application requirements

Choice of external or internal step control

In most applications MSE570 will be operated in conjunction with an external control source consisting of a clock pulse train to determine rate and distance together with a direction signal. Where operation off line from the control processor is required a print on the circuit board is provided for the user to add a simple voltage controlled oscillator to facilitate manual control of the motor drive system.

Thermal Protection

A thermal sensor may be fitted to prevent overheating of the heatsink and output stages. The sensor, such as the Airpax type 67L080, may be clipped to the heatsink and soldered in position at location 'SW3' When fitted an over-temperature signal is provided @ pin 20C This condition may be latched by setting SW1-2(LT) on. The drive may be automatically disabled on overtemperature by setting switch SW1-1 on.

Status LED's for condition monitoring

Provision on the MSE 570 drive board has been made for the user to add five status LED's. These may be soldered in location at the front edge of the board to provide a visual indication of drive condition. The function of each indicator is shown in the table.

LED 1	Green	Power in on
LED 2	yellow	Output is disabled
LED 3	Red	Over-temperature fault detected
LED 4	Red	Overload fault detected
LED 5	Yellow	Home phase output

Type without front panel Type with front panel		MSE570 PM 570	Notes
Supply Voltage	Vdc	15-36 + 10% max.	Max ripple: 3 V peak/Peak Depending on motor selected Chopped constant current Open circuit for full step
Current consumption	Amps	1-3 A	
Output Stage		2 Phase Bi-polar	
Step logic		Full step / half step	
Logic Supply Voltage	Vdc	15-24 + 10% max	Use motor supply if ≤ 24 Vdc
Output Stage			
Output current per phase	Amps	2 Phase Bi-polar 0.5 to 3.5	Chopped constant current Set by on-board DIP switch Open circuit for full step
Step logic		Full step / half step	
Control signals		CMOS Schmidt trigger	
Logic 0: (Low)	Volts	0 to 2	@ 12V with 10K Ω pull-up resistors & diode isolation or contact closure to 0V or open circuit
Logic 1: (high)	Volts	9V to 30V max.	
Monitor Outputs			Referenced to 0V @ 30mA max. + 24V max.
Low Level	Volts	Open collector NPN transistor 1 max.	
High Level	Volts	Open Circuit	
Auxiliary outputs	Vdc	Regulated +12 @ 50mA max. Regulated + 5 @ 50mA max.	For use with on-board oscillator
Up-grade options			User fit options: refer to manual
On board Oscillator		Optional	
Thermal Protection		Optional	
Condition monitoring		Optional	
Dimensions	Mm	100 high x 160 long x 60	Std. Eurocard : Use12E wide panel

Typical Connections

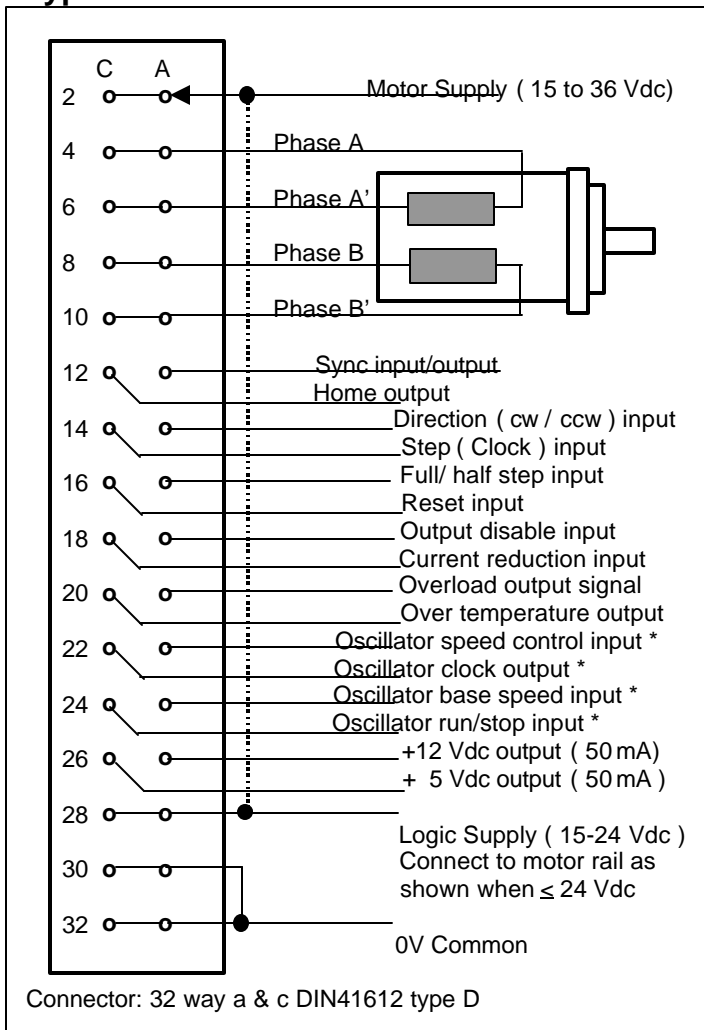

External Oscillator connections *

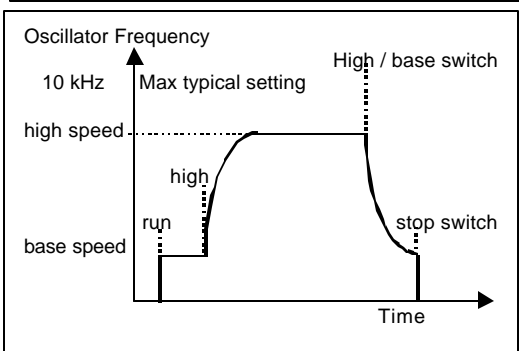
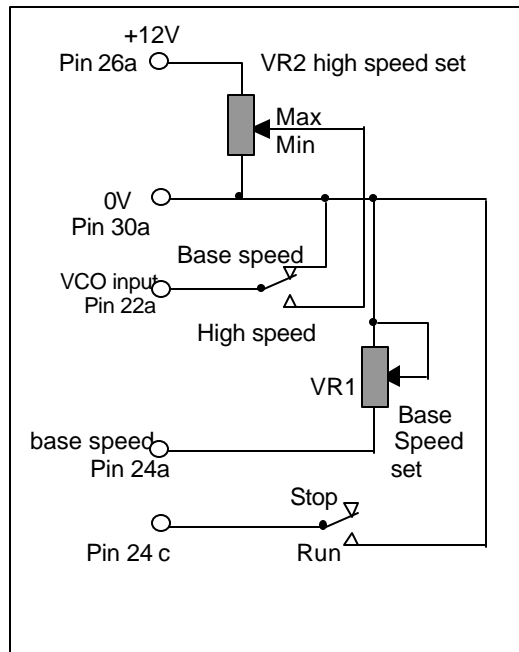

Note* Oscillator connections when circuit is fitted to MSE 570 Printed circuit board

Stepper motor drive current settings

MSE570

The motor phase current can be set to suit the motor to be driven by the use of the on-board DIP switch fitted to the MSE570. The table below shows the nominal phase currents for each setting

Switch Setting				Nominal Current per phase (Amps)	Typical Motor	Motor Connections	Typical Power Supply consumption @ 36 Vdc (Amps)
SW2-1	SW2-2	SW2-3	SW2-4				
off	off	off	off	0			
off	off	off	on	0.5			1.0
off	off	on	off	0.9	17HS-020	Single winding	1.1
off	off	on	on	1.2	23HS-102	parallel	1.2
off	on	off	off	1.3			1.3
off	on	off	on	1.6			1.4
off	on	on	off	1.85	34HS-106	series	1.5
off	on	on	on	2.1	23HS-104 34HS-209	parallel series	1.6
on	off	off	off	2.3	23HS-304	parallel	1.7
on	off	off	on	2.5	34HS-109	series	2.0
on	off	on	off	2.7			2.2
on	off	on	on	2.9	34HS-106	parallel	2.4
on	on	off	off	3.0			2.5
on	on	off	on	3.1			2.6
on	on	on	off	3.3			2.8
on	on	on	on	3.5	23HS-309 34HS-109 34HS-209	parallel parallel parallel	3.0

Rack mounting power supply

MSE562

The MSE 562 is designed for mounting in a 3U high Eurorack and is ideal for use with the MSE570 drive card. The unit will power up to 2 small motor axes or a single axis using a 34HS size motor. For applications requiring multi-axis operation using a combination of motors requiring high current settings the MSE173 Power supply is recommended to drive up to 4 motors.

MSE562 provides a 35 Vdc motor rail for optimum high speed operation using the MSE570 drive together with a 24 Vdc supply for the drive's on-board logic circuits.

Alternatively where a small motor is to be used with the PM546 Drive to obtain ultra high speed operation the 70 Vdc rail may be utilised.



Specification

Width	142.2 mm (28E)
Depth	220 mm
Mounting	3U high rack installation
Connector	DIN41612 type D (32 way a & c)
AC Supply	230 / 115 Vac 50 or 60 Hz.

Outputs:

5V \pm 0.25 V	1.5A Max	100mV ripple max.
24V \pm 2.0 V	1.0 A Max.	2.5 V ripple max.
35V \pm 3.0 V	3.0A Max	4.0 V ripple max.
70V \pm 3.0 V	2.0 A Max	14.0 V ripple max.

Connections:

Refer to handbook

Performance using MSE570 with 35Vdc supply



Coils in parallel, 1.2 amps per phase

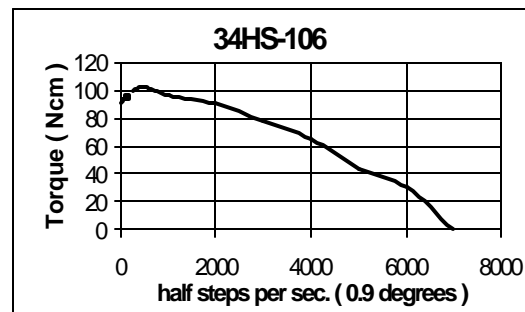

Coils in parallel, 2.9 amps per phase

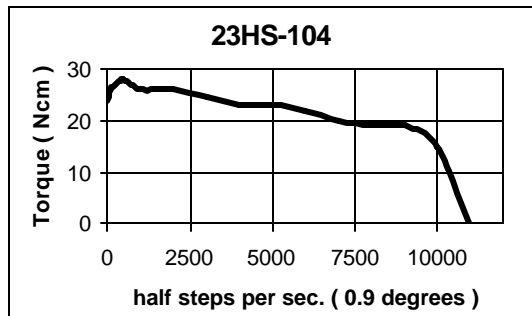

Coils in parallel, 2.1 amps per phase

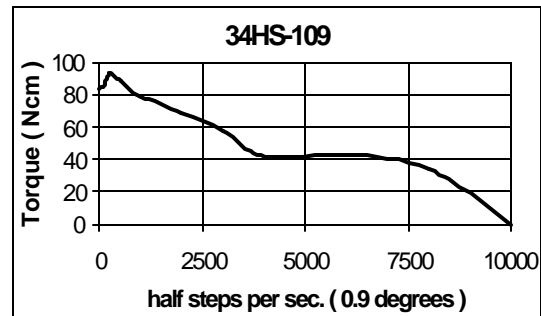

Coils in parallel, 3.5 amps per phase

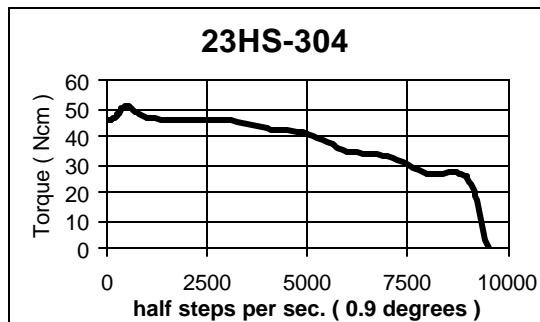

Coils in parallel, 2.3 amps per phase

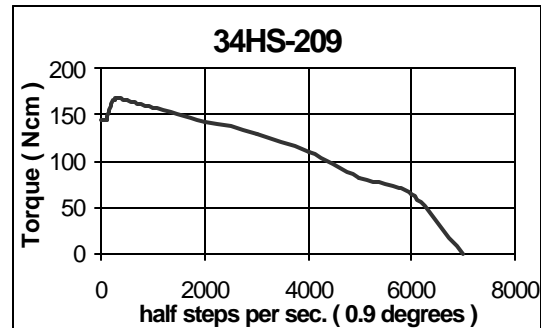

Coils in parallel, 3.5 amps per phase

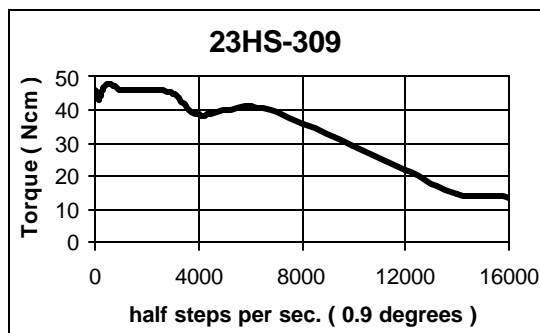

Coils in parallel, 3.5 amps per phase

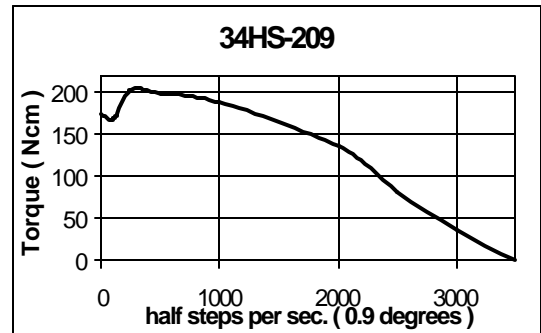

Coils in series. 2.1 amps per phase