



**POSITIVE ADJUSTABLE, LOW DROPOUT
SURFACE MOUNT
VOLTAGE REGULATORS**

5231

M.S.KENNEDY CORP.

4707 Dey Road Liverpool, N.Y. 13088

(315) 701-6751

FEATURES:

- Hermetic Surface Mount Package
- Low Dropout Voltage: 1.5V @ 2 Amps
- Adjustable Output Voltage
- On Board Thermal Overload Protection
- Short Circuit Current Limiting
- Output Current to 3 Amps
- Second Source for OM185
- Pin Compatible with the OM7628NM

MIL-PRF-38534 QUALIFIED

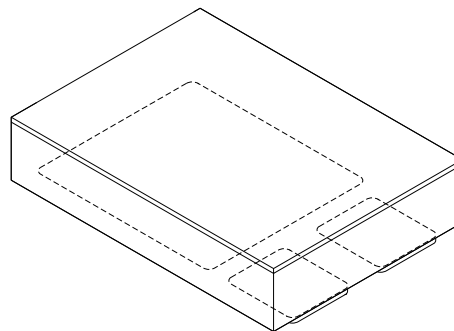

DESCRIPTION:

The MSK 5231 voltage regulator is a positive adjustable regulator that with proper heatsinking, can provide 3 Amps of output current. Low dropout and impressive thermal characteristics help to improve efficiency and lower power dissipation. An accurate reference voltage allows for precise output adjustment. The MSK 5231 is packaged in a hermetic, space efficient 3 pin power surface mount ceramic package.

EQUIVALENT SCHEMATIC

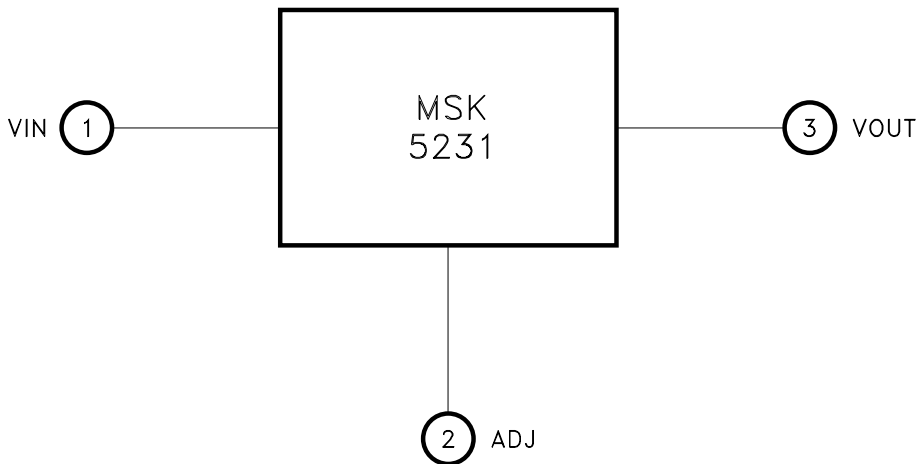

TYPICAL APPLICATIONS

- High Efficiency, High Current Linear Regulators
- Constant Current Regulators
- System Power Supplies
- Switching Power Supply Post Regulators
- Battery Chargers

PIN-OUT INFORMATION

- 1 VIN
- 2 Adjust
- 3 VOUT

ABSOLUTE MAXIMUM RATINGS

V_{IN} Input to Output Voltage Differential 35V
 I_{OUT} Output Current 4A
 P_D Power Dissipation Internally Limited

T_{ST} Storage Temperature Range . . . -65°C to +150°C
 T_{LD} Lead Temperature 300°C
 (10 Seconds Soldering)
 T_J Operating Temperature
 MSK 5231 -40°C to +85°C
 MSK 5231H/E -55°C to +125°C

ELECTRICAL SPECIFICATIONS

Parameter	Test Conditions ① ④	Group A Subgroup	MSK 5231H/E			MSK 5231			Units
			Min.	Typ.	Max.	Min.	Typ.	Max.	
Reference Voltage	$(V_{IN}-V_{OUT}) = 3V$ $I_{OUT} = 10mA$	1	1.238	1.250	1.262	1.230	1.250	1.270	V
	$1.5V \leq (V_{IN}-V_{OUT}) \leq 25V$ $10mA \leq I_{OUT} \leq 2.0A$	1	1.220	1.250	1.270	1.215	1.250	1.275	V
		2,3	1.220	1.250	1.270	-	-	-	V
Dropout Voltage ②	$I_{OUT} = 2.0A$ $\Delta V_{REF} = 1\%$	1	-	1.3	1.5	-	1.3	1.5	V
		2,3	-	1.3	1.5	-	-	-	V
Line Regulation	$1.5V \leq (V_{IN}-V_{OUT}) \leq 15V$ $I_{OUT} = 10mA$	1	-	0.02	0.2	-	0.02	0.4	%
	$15V \leq (V_{IN}-V_{OUT}) \leq 35V$ $I_{OUT} = 10mA$	2,3	-	0.05	0.5	-	-	-	%
Load Regulation	$V_{IN}-V_{OUT} = 3V$ $10mA \leq I_{OUT} \leq 2.0A$	1	-	0.1	0.8	-	0.1	1.0	%
		2,3	-	0.2	1.0	-	-	-	%
Current Limit ②	$V_{IN}-V_{OUT} = 5.0V$	1	3.2	4.0	2	3.2	4.0	-	A
		2,3	3.2	4.0	-	-	-	-	A
	$V_{IN}-V_{OUT} = 25V$	1	0.2	0.5	-	0.2	0.5	-	A
		2,3	0.2	0.5	-	-	-	-	A
Ripple Rejection ②	$F = 120Hz$ $C_{ADJ} = 25\mu F$ $C_{OUT} = 25\mu F$ $I_{OUT} = 2.0A$ $V_{IN}-V_{OUT} = 3.0V$	4	60	75	-	60	75	-	dB
Adjust Pin Current	$1.5V \leq (V_{IN}-V_{OUT}) \leq 25V$ $10mA \leq I_{OUT} \leq 2.0A$	1	-	55	120	-	55	120	μA
		2,3	-	55	120	-	-	-	μA
Minimum Load Current ②	$(V_{IN}-V_{OUT}) = 24V$	1	-	5	10	-	5	10	mA
		2,3	-	5	10	-	-	-	mA
Thermal Regulation ②	30mS pulse $T_A = 25^\circ C$	1	-	0.004	0.02	-	0.004	0.02	%/W
Temperature Stability ②	$-55^\circ C \leq T_J \leq +125^\circ C$	-	-	0.5	-	-	0.5	-	%
Thermal Resistance ②	Junction to Case @ 125°C	-	-	0.8	1.5	-	0.8	1.7	$^\circ C/W$

NOTES:

- ① Output decoupled to ground using 20 μF minimum capacitor unless otherwise specified.
- ② This parameter is guaranteed by design but need not be tested.
- ③ Typical parameters are representative of actual device performance but are for reference only.
- ④ All output parameters are tested using a low duty cycle pulse to maintain $T_J = T_C$.
- ⑤ Industrial grade and "E" suffix devices shall be tested to subgroup 1 unless otherwise specified.
- ⑥ Military grade devices ('H' suffix) shall be 100% tested to subgroups 1,2,3.
- ⑦ Subgroup 1,4 $T_A = T_C = +25^\circ C$
 2,5 $T_A = T_C = +125^\circ C$
 3,6 $T_A = T_C = -55^\circ C$

APPLICATION NOTES

OVERLOAD SHUTDOWN

The MSK 5231 features both power and thermal overload protection. When the maximum power dissipation is not exceeded, the regulator will current limit slightly above its 3 amp rating. As the V_{IN} - V_{OUT} voltage increases, however, shutdown occurs in relation to the maximum power dissipation curve. If the device heats enough to exceed its related die junction temperature due to excessive ambient temperature, improper heat sinking etc., the regulator shuts down until an appropriate junction temperature is maintained. It should also be noted that in the case of an extreme overload, such as sustained direct short, the device may not be able to recover. In these instances, the device must be shut off and power reapplied to eliminate the shutdown condition.

HEAT SINKING

To determine if a heat sink is required for your application and if so, what type, refer to the thermal model and governing equation below.

Governing Equation: $T_j = P_d \times (R_{\theta jc} + R_{\theta cs} + R_{\theta sa}) + T_a$

WHERE

- T_j = Junction Temperature
- P_d = Total Power Dissipation
- $R_{\theta jc}$ = Junction to Case Thermal Resistance
- $R_{\theta cs}$ = Case to Heat Sink Thermal Resistance
- $R_{\theta sa}$ = Heat Sink to Ambient Thermal Resistance
- T_c = Case Temperature
- T_a = Ambient Temperature
- T_s = Heat Sink Temperature

EXAMPLE:

This example demonstrates an analysis where the regulator is at one-half of its maximum rated power dissipation, which occurs when the output current is at 1.5 amps.

$$V_{IN} = +7.0V \quad V_{OUT} = +5.0V$$

$$I_{OUT} = 1.5A$$

- 1.) Assume 45° heat spreading model.
- 2.) Find power dissipation:

$$P_d = (V_{IN} - V_{OUT}) (I_{OUT})$$

$$P_d = (7-5) (1.5)$$

$$= 3.0W$$

- 3.) For conservative design, set $T_J = +125^\circ C$ Max.
- 4.) For this example, worst case $T_A = +90^\circ C$.
- 5.) $R_{\theta jc} = 1.5^\circ C/W$ from the Electrical Specification Table.
- 6.) $R_{\theta cs} = 0.15^\circ C/W$ for most thermal greases.
- 7.) Rearrange governing equation to solve for $R_{\theta sa}$:

$$R_{\theta sa} = ((T_J - T_A)/P_d) - (R_{\theta jc}) - (R_{\theta cs})$$

$$= (125^\circ C - 90^\circ C)/3.0W - 1.5^\circ C/W - 0.15^\circ C/W$$

$$= 10.0^\circ C/W$$

In this case the result is $10.0^\circ C/W$. Therefore, a heat sink with a thermal resistance of no more than $10.0^\circ C/W$ must be used in this application to maintain regulator circuit junction temperature under $125^\circ C$.

STABILITY

For stable operation in most applications it is recommended that a $10\mu f$ tantalum capacitor be used at the input of the regulator. In addition, if the regulator is not located very close to the power supply filter capacitors, a $4.7\mu f$ low ESR tantalum capacitor should be added to the regulator's input. Electrolytic capacitors may also be used. When substituting an electrolytic in place of a tantalum the value should be increased by a factor of ten over the tantalum value.

The output of the regulator should be bypassed using a minimum $10\mu f$ tantalum capacitor. To ensure good transient response under heavy load conditions the output capacitor may be increased without limit. Larger capacitance values will further improve stability and transient response.

LOAD REGULATION

Load regulation will be limited by the resistance of the wire connecting the regulator to the load. For example, if 20 gauge wire were used which has a resistance of approximately 0.008 ohms per foot, this would result in a voltage drop of 8mV/ft at 1 amp of load current. Also, best load regulation will be seen when the adjust resistor, R1, is connected directly to the regulator and not to the load. In addition, it is important to follow the capacitor selection guidelines for stability and load regulation performance.

OUTPUT VOLTAGE

The MSK 5231 requires two external resistors to set the output voltage. A 1.25 volt reference voltage is developed between the output and adjust pins. Resistor, R1, is placed between these pins with a second resistor, R2, placed from the adjust pin to ground. A constant current will flow from the output through these two resistors to set the output voltage. The series resistance of R1 & R2 should be selected to provide a minimum load current of 10mA.

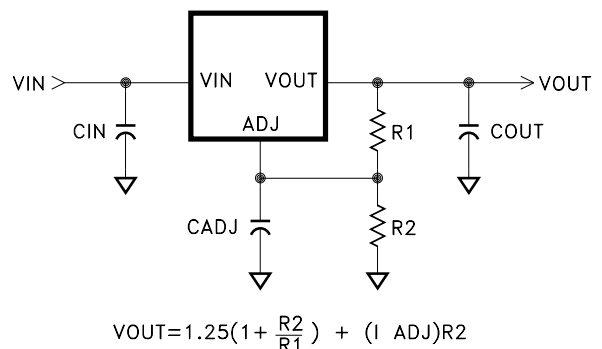

TYPICAL PERFORMANCE CURVES

DROPOUT VOLTAGE vs. OUTPUT CURRENT

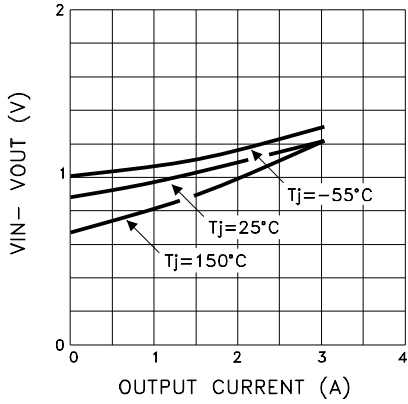

LOAD REGULATION vs. TEMPERATURE

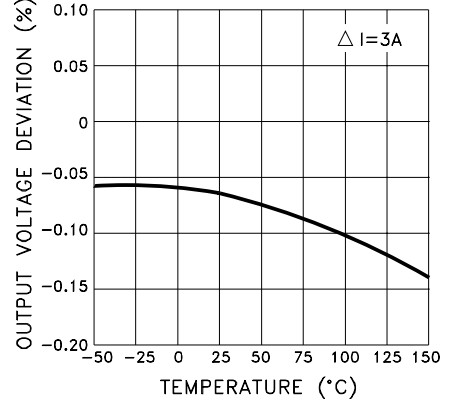

INTERNAL CURRENT LIMIT vs. VIN-VOUT

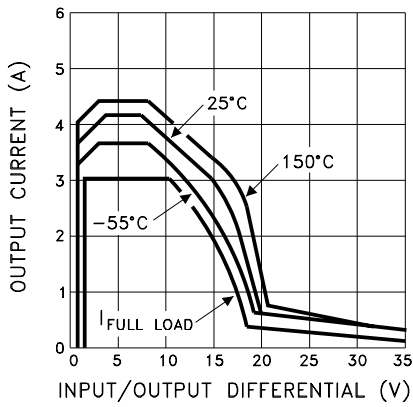

ADJUST PIN CURRENT vs. TEMPERATURE

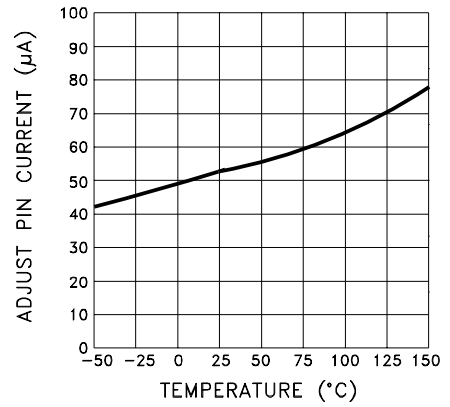

RIPPLE REJECTION vs. FREQUENCY

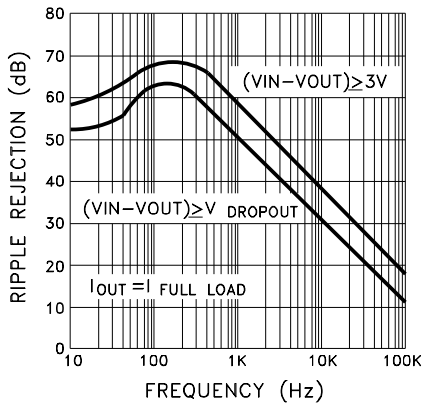

LINE TRANSIENT RESPONSE

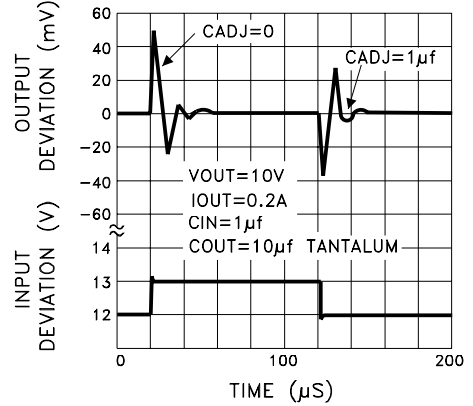

LOAD TRANSIENT RESPONSE

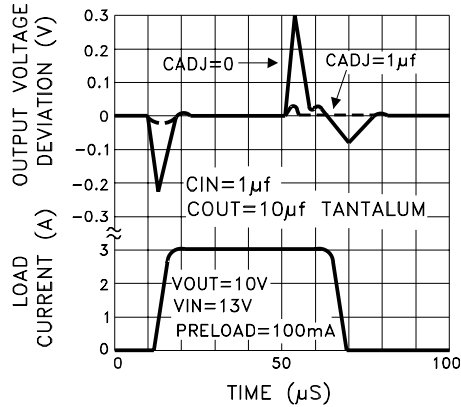

MECHANICAL SPECIFICATIONS

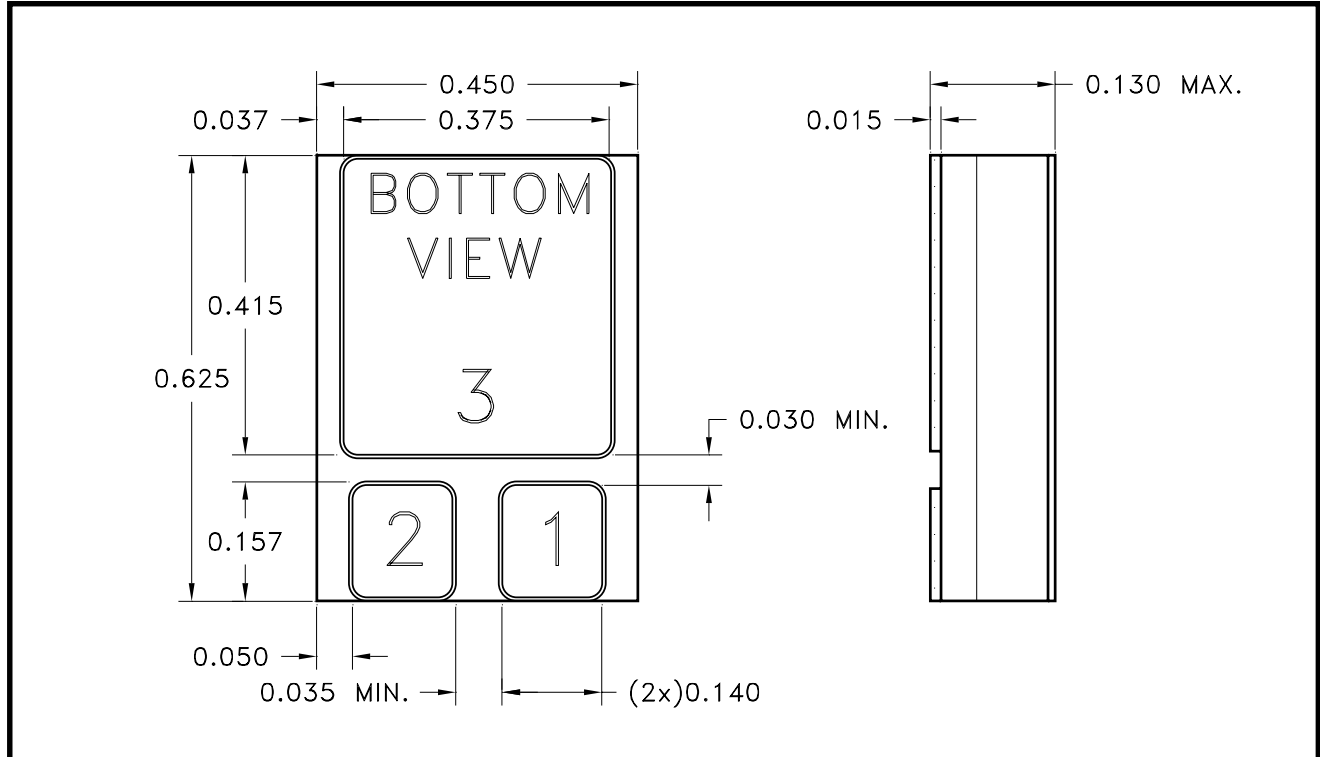

NOTE: ALL DIMENSIONS ARE ± 0.010 INCHES UNLESS OTHERWISE LABELED.

ORDERING INFORMATION

MSK5231 H

SCREENING

BLANK = INDUSTRIAL; E = EXTENDED RELIABILITY

H = MIL-PRF-38534 CLASS H

GENERAL PART NUMBER

M.S. Kennedy Corp.
 4707 Dey Road, Liverpool, New York 13088
 Phone (315) 701-6751
 FAX (315) 701-6752
 www.mskennedy.com