

MSM518121A

131,072-Word × 8-Bit Multiport DRAM

DESCRIPTION

The MSM518121A is an 1-Mbit CMOS multiport memory composed of a 131,072-words by 8-bit dynamic random access memory, RAM port, and a 256-word by 8-bit static serial access memory, SAM port. The RAM port and SAM port operate independently and asynchronously. The MSM518121A supports three types of operation: random access to and from the RAM port, high speed serial access to and from the SAM port and bidirectional transfer of data between any selected row in the RAM port and the SAM port. The RAM port and the SAM port can be accessed independently except when data is being transferred between them internally.

FEATURES

- Single power supply of 5 V ±10% with a built-in VBB generator
- All inputs and outputs :TTL compatible
- Multiport organization
 RAM port : 128K word × 8 bits
 SAM port : 256 word × 8 bits
- RAM port
 Fast page mode, Read modify write
 $\overline{\text{CAS}}$ before $\overline{\text{RAS}}$ refresh, Hidden refresh
 $\overline{\text{RAS}}$ only refresh, Standard write-per-bit
- SAM port
 High speed serial
 Read / Write capability
 Fully static register
 256 tap location
- RAM-SAM bidirectional, Read / Write / Pseudo write, Real time read transfer
- Package options:
 40-pin 475 mil plastic ZIP (ZIP40-P-475-1.27) (Product : MSM518121A-xxZS)
 40-pin 400 mil plastic SOJ (SOJ40-P-400-1.27) (Product : MSM518121A-xxJS)
 xx indicates speed rank.

PRODUCT FAMILY

| Family | Access Time | | Cycle Time | | Power Dissipation | |
|---------------|-------------|-------|------------|-------|-------------------|---------|
| | RAM | SAM | RAM | SAM | Operating | Standby |
| MSM518121A-70 | 70 ns | 25 ns | 140 ns | 30 ns | 120 mA | 8 mA |
| MSM518121A-80 | 80 ns | 25 ns | 150 ns | 30 ns | 110 mA | 8 mA |
| MSM518121A-10 | 100 ns | 25 ns | 180 ns | 30 ns | 100 mA | 8 mA |

PIN CONFIGURATION (TOP VIEW)

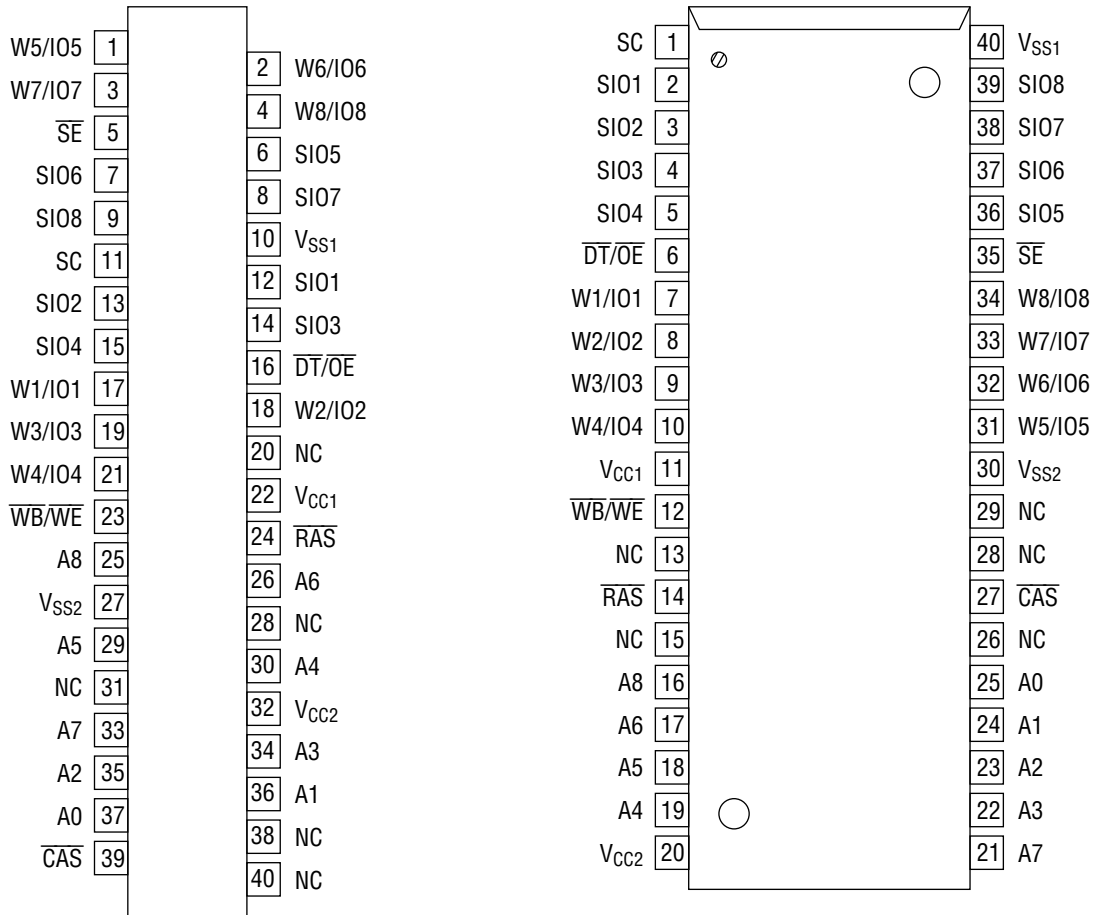

40-Pin Plastic ZIP

40-Pin Plastic SOJ

| Pin Name | Function |
|-----------------------------------|-----------------------------------|
| A0 - A8 | Address Input |
| \overline{RAS} | Row Address Strobe |
| \overline{CAS} | Column Address Strobe |
| $\overline{DT} / \overline{OE}$ | Data Transfer / Output Enable |
| $\overline{WB} / \overline{WE}$ | Write per Bit / Write Enable |
| W1/I01 - W8/I08 | Write Mask / Data IN, OUT |
| SC | Serial Clock |
| \overline{SE} | Serial Enable |
| SI01 - SI08 | Serial Input / Output |
| V _{CC} / V _{SS} | Power Supply (5 V) / Ground (0 V) |
| NC | No Connection |

Note: The same power supply voltage must be provided to every V_{CC} pin, and the same GND voltage level must be provided to every V_{SS} pin.

BLOCK DIAGRAM

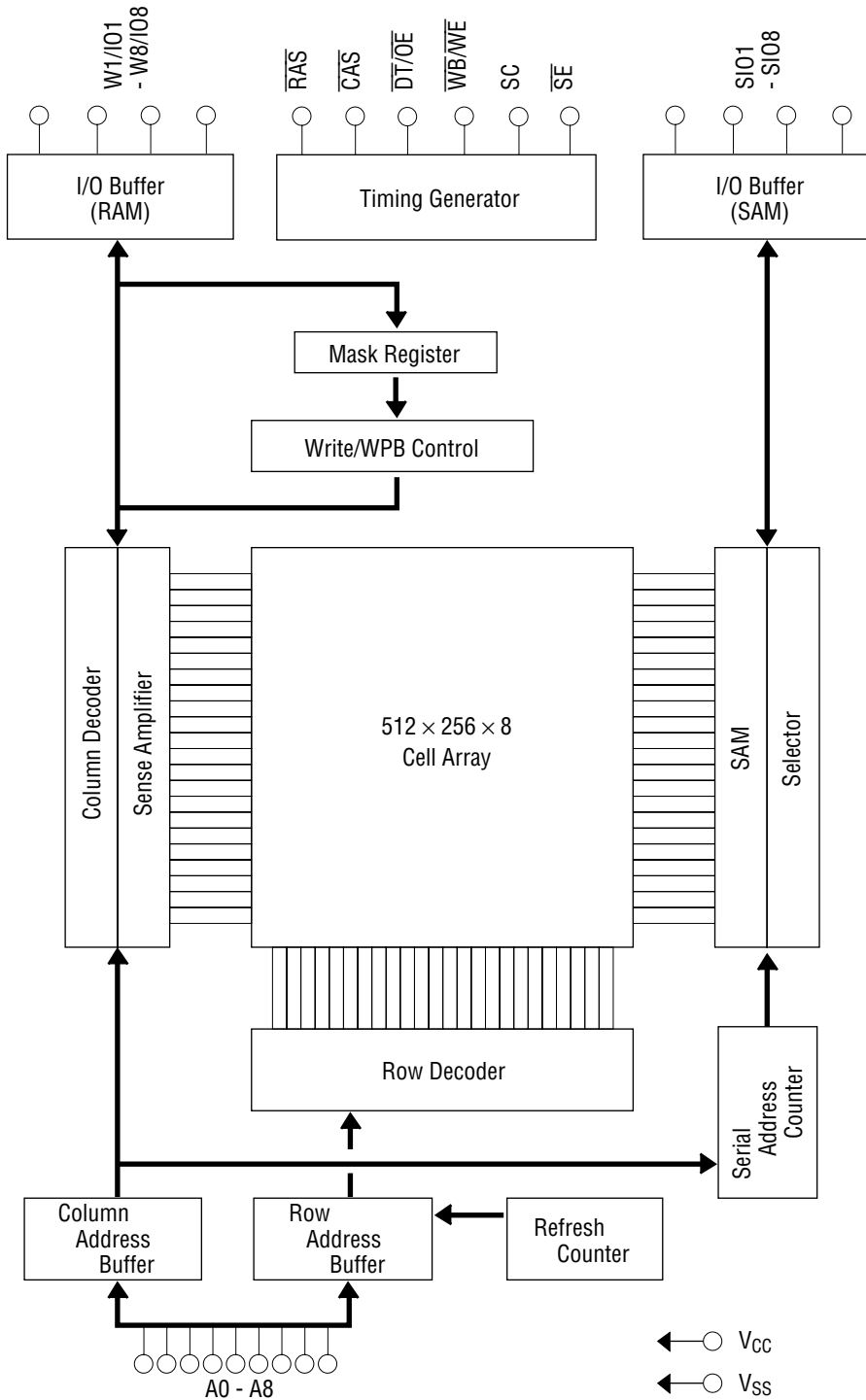

ELECTRICAL CHARACTERISTICS

Absolute Maximum Ratings

(Note : 16)

| Parameter | Symbol | Condition | Rating | Unit |
|-----------------------|-----------|--------------------------|-------------|------------------|
| Input Output Voltage | V_T | $T_a = 25^\circ\text{C}$ | -1.0 to 7.0 | V |
| Output Current | I_{OS} | $T_a = 25^\circ\text{C}$ | 50 | mA |
| Power Dissipation | P_D | $T_a = 25^\circ\text{C}$ | 1 | W |
| Operating Temperature | T_{opr} | — | 0 to 70 | $^\circ\text{C}$ |
| Storage Temperature | T_{stg} | — | -55 to 150 | $^\circ\text{C}$ |

Recommended Operating Conditions

(Ta = 0°C to 70°C) (Note : 17)

| Parameter | Symbol | Min. | Typ. | Max. | Unit |
|----------------------|----------|------|------|------|------|
| Power Supply Voltage | V_{CC} | 4.5 | 5.0 | 5.5 | V |
| Input High Voltage | V_{IH} | 2.4 | — | 6.5 | V |
| Input Low Voltage | V_{IL} | -1.0 | — | 0.8 | V |

Capacitance

(V_{CC} = 5 V ±10%, f = 1 MHz, T_a = 25°C)

| Parameter | Symbol | Min. | Max. | Unit |
|----------------------------|-----------|------|------|------|
| Input Capacitance | C_I | — | 7 | pF |
| Input / Output Capacitance | $C_{I/O}$ | — | 9 | pF |

Note : This parameter is periodically sampled and is not 100% tested.

DC Characteristics 1

| Parameter | Symbol | Condition | Min. | Max. | Unit |
|--------------------------|----------|---|------|------|---------------|
| Output "H" Level Voltage | V_{OH} | $I_{OH} = -2 \text{ mA}$ | 2.4 | — | V |
| Output "L" Level Voltage | V_{OL} | $I_{OL} = 2 \text{ mA}$ | — | 0.4 | |
| Input Leakage Current | I_{LI} | $0 \leq V_{IN} \leq V_{CC}$ All other pins not under test = 0 V | -10 | 10 | μA |
| Output Leakage Current | I_{LO} | $0 \leq V_{OUT} \leq 5.5 \text{ V}$ Output Disable | -10 | 10 | |

DC Characteristics 2

(V_{CC} = 5 V ±10%, T_a = 0°C to 70°C)

| Item (RAM) | SAM | Symbol | -70 | -80 | -10 | Unit | Note |
|--|---------|-------------------|------|------|------|------|------|
| | | | Max. | Max. | Max. | | |
| Operating Current ($\overline{\text{RAS}}$, $\overline{\text{CAS}}$ Cycling, $t_{\text{RC}} = t_{\text{RC min.}}$) | Standby | I _{CC1} | 85 | 75 | 65 | mA | 1, 2 |
| | Active | I _{CC1A} | 120 | 110 | 100 | | 1, 2 |
| Standby Current ($\overline{\text{RAS}}$, $\overline{\text{CAS}} = V_{\text{IH}}$) | Standby | I _{CC2} | 8 | 8 | 8 | | 3 |
| | Active | I _{CC2A} | 50 | 45 | 40 | | 1, 2 |
| $\overline{\text{RAS}}$ Only Refresh Current ($\overline{\text{RAS}}$ Cycling, $\overline{\text{CAS}} = V_{\text{IH}}$, $t_{\text{RC}} = t_{\text{RC min.}}$) | Standby | I _{CC3} | 85 | 75 | 65 | | 1, 2 |
| | Active | I _{CC3A} | 120 | 110 | 100 | | 1, 2 |
| Page Mode Current ($\overline{\text{RAS}} = V_{\text{IL}}$, $\overline{\text{CAS}}$ Cycling, $t_{\text{PC}} = t_{\text{PC min.}}$) | Standby | I _{CC4} | 70 | 65 | 60 | | 1, 2 |
| | Active | I _{CC4A} | 120 | 110 | 100 | | 1, 2 |
| $\overline{\text{CAS}}$ before $\overline{\text{RAS}}$ Refresh Current ($\overline{\text{RAS}}$ Cycling, $\overline{\text{CAS}}$ before $\overline{\text{RAS}}$, $t_{\text{RC}} = t_{\text{RC min.}}$) | Standby | I _{CC5} | 85 | 75 | 65 | | 1, 2 |
| | Active | I _{CC5A} | 120 | 110 | 100 | | 1, 2 |
| Data Transfer Current ($\overline{\text{RAS}}$, $\overline{\text{CAS}}$ Cycling, $t_{\text{RC}} = t_{\text{RC min.}}$) | Standby | I _{CC6} | 85 | 75 | 65 | | 1, 2 |
| | Active | I _{CC6A} | 120 | 110 | 100 | | 1, 2 |

AC Characteristics (1/3)

(V_{CC} = 5 V ±10%, T_a = 0°C to 70°C) Note 4, 5, 6

| Parameter | Symbol | -70 | | -80 | | -10 | | Unit | Note |
|---|-------------------|------|------|------|------|------|------|------|-------|
| | | Min. | Max. | Min. | Max. | Min. | Max. | | |
| Random Read or Write Cycle Time | t _{RC} | 140 | — | 150 | — | 180 | — | ns | |
| Read Modify Write Cycle Time | t _{RWC} | 195 | — | 195 | — | 235 | — | ns | |
| Fast Page Mode Cycle Time | t _{PC} | 45 | — | 50 | — | 55 | — | ns | |
| Fast Page Mode Read Modify Write Cycle Time | t _{PRWC} | 90 | — | 90 | — | 100 | — | ns | |
| Access Time from $\overline{\text{RAS}}$ | t _{RAC} | — | 70 | — | 80 | — | 100 | ns | 7, 13 |
| Access Time from Column Address | t _{AA} | — | 35 | — | 40 | — | 55 | ns | 7, 13 |
| Access Time from $\overline{\text{CAS}}$ | t _{CAC} | — | 20 | — | 25 | — | 25 | ns | 7, 14 |
| Access Time from $\overline{\text{CAS}}$ Precharge | t _{CPA} | — | 40 | — | 45 | — | 50 | ns | 7, 14 |
| Output Buffer Turn-off Delay | t _{OFF} | 0 | 20 | 0 | 20 | 0 | 20 | ns | 9 |
| Transition Time (Rise and Fall) | t _T | 3 | 35 | 3 | 35 | 3 | 35 | ns | 6 |
| $\overline{\text{RAS}}$ Precharge Time | t _{RP} | 60 | — | 60 | — | 70 | — | ns | |
| $\overline{\text{RAS}}$ Pulse Width | t _{RAS} | 70 | 10k | 80 | 10k | 100 | 10k | ns | |
| $\overline{\text{RAS}}$ Pulse Width (Fast Page Mode Only) | t _{RASP} | 70 | 100k | 80 | 100k | 100 | 100k | ns | |
| $\overline{\text{RAS}}$ Hold Time | t _{RSH} | 20 | — | 25 | — | 25 | — | ns | |
| $\overline{\text{CAS}}$ Hold Time | t _{CSH} | 70 | — | 80 | — | 100 | — | ns | |
| $\overline{\text{CAS}}$ Pulse Width | t _{CAS} | 20 | 10k | 25 | 10k | 25 | 10k | ns | |
| $\overline{\text{RAS}}$ to $\overline{\text{CAS}}$ Delay Time | t _{RCD} | 20 | 50 | 20 | 55 | 20 | 75 | ns | 13 |
| $\overline{\text{RAS}}$ to Column Address Delay Time | t _{RAD} | 15 | 35 | 15 | 40 | 20 | 50 | ns | 13 |
| Column Address to $\overline{\text{RAS}}$ Lead Time | t _{RAL} | 35 | — | 40 | — | 55 | — | ns | |
| $\overline{\text{CAS}}$ to $\overline{\text{RAS}}$ Precharge Time | t _{CRP} | 10 | — | 10 | — | 10 | — | ns | |
| $\overline{\text{CAS}}$ Precharge Time | t _{CPN} | 10 | — | 10 | — | 10 | — | ns | |
| $\overline{\text{CAS}}$ Precharge Time (Fast Page Mode) | t _{CP} | 10 | — | 10 | — | 10 | — | ns | |
| Row Address Set-up Time | t _{ASR} | 0 | — | 0 | — | 0 | — | ns | |
| Row Address Hold Time | t _{RAH} | 10 | — | 10 | — | 10 | — | ns | |
| Column Address Set-up Time | t _{ASC} | 0 | — | 0 | — | 0 | — | ns | |
| Column Address Hold Time | t _{CAH} | 15 | — | 15 | — | 15 | — | ns | |
| Column Address Hold Time referenced to $\overline{\text{RAS}}$ | t _{AR} | 55 | — | 55 | — | 70 | — | ns | |
| Read Command Set-up Time | t _{RCS} | 0 | — | 0 | — | 0 | — | ns | |
| Read Command Hold Time | t _{RCH} | 0 | — | 0 | — | 0 | — | ns | 10 |
| Read Command Hold Time referenced to $\overline{\text{RAS}}$ | t _{RRH} | 0 | — | 0 | — | 0 | — | ns | 10 |
| Write Command Hold Time | t _{WCH} | 15 | — | 15 | — | 15 | — | ns | |
| Write Command Hold Time referenced to $\overline{\text{RAS}}$ | t _{WCR} | 55 | — | 55 | — | 70 | — | ns | |
| Write Command Pulse Width | t _{WP} | 15 | — | 15 | — | 15 | — | ns | |
| Write Command to $\overline{\text{RAS}}$ Lead Time | t _{RWL} | 20 | — | 20 | — | 25 | — | ns | |
| Write Command to $\overline{\text{CAS}}$ Lead Time | t _{CWL} | 20 | — | 20 | — | 25 | — | ns | |

AC Characteristics (2/3)

(V_{CC} = 5 V ±10%, Ta = 0°C to 70°C) Note 4, 5, 6

| Parameter | Symbol | -70 | | -80 | | -10 | | Unit | Note |
|---|------------------|------|------|------|------|------|------|------|------|
| | | Min. | Max. | Min. | Max. | Min. | Max. | | |
| Data Set-up Time | t _{DS} | 0 | — | 0 | — | 0 | — | ns | 11 |
| Data Hold Time | t _{DH} | 15 | — | 15 | — | 15 | — | ns | 11 |
| Data Hold Time referenced to $\overline{\text{RAS}}$ | t _{DHR} | 55 | — | 55 | — | 70 | — | ns | |
| Write Command Set-up Time | t _{WCS} | 0 | — | 0 | — | 0 | — | ns | 12 |
| $\overline{\text{RAS}}$ to $\overline{\text{WE}}$ Delay Time | t _{RDW} | 100 | — | 100 | — | 130 | — | ns | 12 |
| Column Address to $\overline{\text{WE}}$ Delay Time | t _{AWD} | 65 | — | 65 | — | 80 | — | ns | 12 |
| $\overline{\text{CAS}}$ to $\overline{\text{WE}}$ Delay Time | t _{CWD} | 45 | — | 45 | — | 55 | — | ns | 12 |
| Data to $\overline{\text{CAS}}$ Delay Time | t _{DZC} | 0 | — | 0 | — | 0 | — | ns | |
| Data to $\overline{\text{OE}}$ Delay Time | t _{DZO} | 0 | — | 0 | — | 0 | — | ns | |
| Access Time from $\overline{\text{OE}}$ | t _{QEA} | — | 20 | — | 20 | — | 25 | ns | 7 |
| Output Buffer Turn-off Delay from $\overline{\text{OE}}$ | t _{QEZ} | 0 | 10 | 0 | 10 | 0 | 20 | ns | 9 |
| $\overline{\text{OE}}$ to Data Delay Time | t _{QED} | 10 | — | 10 | — | 20 | — | ns | |
| $\overline{\text{OE}}$ Command Hold Time | t _{QEH} | 10 | — | 10 | — | 20 | — | ns | |
| $\overline{\text{RAS}}$ Hold Time referenced to $\overline{\text{OE}}$ | t _{ROH} | 15 | — | 15 | — | 15 | — | ns | |
| $\overline{\text{CAS}}$ Set-up Time for $\overline{\text{CAS}}$ before $\overline{\text{RAS}}$ Cycle | t _{CSR} | 10 | — | 10 | — | 10 | — | ns | |
| $\overline{\text{CAS}}$ Hold Time for $\overline{\text{CAS}}$ before $\overline{\text{RAS}}$ Cycle | t _{CHR} | 10 | — | 10 | — | 10 | — | ns | |
| $\overline{\text{RAS}}$ Precharge to $\overline{\text{CAS}}$ Active Time | t _{RPC} | 0 | — | 0 | — | 0 | — | ns | |
| Refresh Period | t _{REF} | — | 8 | — | 8 | — | 8 | ms | |
| $\overline{\text{WB}}$ Set-up Time | t _{WSR} | 0 | — | 0 | — | 0 | — | ns | |
| $\overline{\text{WB}}$ Hold Time | t _{RWH} | 15 | — | 15 | — | 15 | — | ns | |
| Write Per Bit Mask Data Set-up Time | t _{MS} | 0 | — | 0 | — | 0 | — | ns | |
| Write Per Bit Mask Data Hold Time | t _{MH} | 15 | — | 15 | — | 15 | — | ns | |
| $\overline{\text{DT}}$ High Set-up Time | t _{THS} | 0 | — | 0 | — | 0 | — | ns | |
| $\overline{\text{DT}}$ High Hold Time | t _{THH} | 15 | — | 15 | — | 15 | — | ns | |
| $\overline{\text{DT}}$ Low Set-up Time | t _{TLS} | 0 | — | 0 | — | 0 | — | ns | |
| $\overline{\text{DT}}$ Low Hold Time | t _{TLH} | 15 | 10k | 15 | 10k | 15 | 10k | ns | |
| $\overline{\text{DT}}$ Low Hold Time referenced to $\overline{\text{RAS}}$ (Real Time Read Transfer) | t _{RTH} | 60 | 10k | 65 | 10k | 80 | 10k | ns | |
| $\overline{\text{DT}}$ Low Hold Time referenced to Column Address (Real Time Read Transfer) | t _{ATH} | 25 | — | 30 | — | 30 | — | ns | |
| $\overline{\text{DT}}$ Low Hold Time referenced to $\overline{\text{CAS}}$ (Real Time Read Transfer) | t _{CTH} | 20 | — | 25 | — | 25 | — | ns | |
| $\overline{\text{SE}}$ Set-up Time referenced to $\overline{\text{RAS}}$ | t _{ESR} | 0 | — | 0 | — | 0 | — | ns | |
| $\overline{\text{SE}}$ Hold Time referenced to $\overline{\text{RAS}}$ | t _{REH} | 15 | — | 15 | — | 15 | — | ns | |
| $\overline{\text{DT}}$ to $\overline{\text{RAS}}$ Precharge Time | t _{TRP} | 60 | — | 60 | — | 70 | — | ns | |
| $\overline{\text{DT}}$ Precharge Time | t _{TP} | 20 | — | 20 | — | 30 | — | ns | |
| $\overline{\text{RAS}}$ to First SC Delay Time (Read Transfer) | t _{RSD} | 70 | — | 80 | — | 100 | — | ns | |
| Column Address to First SC Delay Time (Read Transfer) | t _{ASD} | 45 | — | 45 | — | 50 | — | ns | |
| $\overline{\text{CAS}}$ to First SC Delay Time (Read Transfer) | t _{CSD} | 20 | — | 25 | — | 25 | — | ns | |
| Last SC to $\overline{\text{DT}}$ Lead Time (Real Time Read Transfer) | t _{TSL} | 5 | — | 5 | — | 5 | — | ns | |

AC Characteristics (3/3)

(V_{CC} = 5 V ±10%, T_a = 0°C to 70°C) Note 4, 5, 6

| Parameter | Symbol | -70 | | -80 | | -10 | | Unit | Note |
|--|-------------------|------|------|------|------|------|------|------|------|
| | | Min. | Max. | Min. | Max. | Min. | Max. | | |
| \overline{DT} to First SC Delay Time (Read Transfer) | t _{TSD} | 15 | — | 15 | — | 15 | — | ns | |
| Last SC to \overline{RAS} Set-up Time (Serial Input) | t _{SRS} | 25 | — | 25 | — | 30 | — | ns | |
| \overline{RAS} to First SC Delay Time (Serial Input) | t _{SRD} | 20 | — | 20 | — | 25 | — | ns | |
| \overline{RAS} to Serial Input Delay Time | t _{SDD} | 40 | — | 40 | — | 50 | — | ns | |
| Serial Output Buffer Turn-off Delay from \overline{RAS} (Pseudo Write Transfer) | t _{SDZ} | 10 | 40 | 10 | 40 | 10 | 50 | ns | 9 |
| SC Cycle Time | t _{SCC} | 30 | — | 30 | — | 30 | — | ns | |
| SC Pulse Width (SC High Time) | t _{SC} | 10 | — | 10 | — | 10 | — | ns | |
| SC Precharge Time (SC Low Time) | t _{SCP} | 10 | — | 10 | — | 10 | — | ns | |
| Access Time from SC | t _{SCA} | — | 25 | — | 25 | — | 25 | ns | 8 |
| Serial Output Hold Time from SC | t _{SOH} | 5 | — | 5 | — | 5 | — | ns | |
| Serial Input Set-up Time | t _{SDS} | 0 | — | 0 | — | 0 | — | ns | |
| Serial Input Hold Time | t _{SDH} | 15 | — | 15 | — | 15 | — | ns | |
| Access Time from \overline{SE} | t _{SEA} | — | 25 | — | 25 | — | 25 | ns | 8 |
| \overline{SE} Pulse Width | t _{SE} | 25 | — | 25 | — | 25 | — | ns | |
| \overline{SE} Precharge Time | t _{SEP} | 25 | — | 25 | — | 25 | — | ns | |
| Serial Output Buffer Turn-off Delay from \overline{SE} | t _{SEZ} | 0 | 20 | 0 | 20 | 0 | 20 | ns | 9 |
| Serial Input to \overline{SE} Delay Time | t _{SZE} | 0 | — | 0 | — | 0 | — | ns | |
| Serial Input to First SC Delay Time | t _{SZS} | 0 | — | 0 | — | 0 | — | ns | |
| Serial Write Enable Set-up Time | t _{SWS} | 5 | — | 5 | — | 5 | — | ns | |
| Serial Write Enable Hold Time | t _{SWH} | 15 | — | 15 | — | 15 | — | ns | |
| Serial Write Disable Set-up Time | t _{SWIS} | 5 | — | 5 | — | 5 | — | ns | |
| Serial Write Disable Hold Time | t _{SWIH} | 15 | — | 15 | — | 15 | — | ns | |

- Notes:
1. These parameters depend on output loading. Specified values are obtained with the output open.
 2. These parameters are measured at minimum cycle test.
 3. I_{CC2} (Max.) are measured under the condition of TTL input level.
 4. V_{IH} (Min.) and V_{IL} (Max.) are reference levels for measuring timing of input signals. Also, transition times are measured between V_{IH} and V_{IL} .
 5. An initial pause of 200 μ s is required after power-up followed by any 8 \overline{RAS} cycles ($\overline{DT}/\overline{OE}$ "high") and any 8 SC cycles before proper device operation is achieved. In the case of using an internal refresh counter, a minimum of 8 \overline{CAS} before \overline{RAS} initialization cycles in stead of 8 \overline{RAS} cycles are required.
 6. AC measurements assume $t_T = 5$ ns.
 7. RAM port outputs are measured with a load equivalent to 1 TTL load and 100 pF. Output reference levels are $V_{OH}/V_{OL} = 2.4$ V/0.8 V.
 8. SAM port outputs are measured with a load equivalent to 1 TTL load and 30 pF. Output reference levels are $V_{OH}/V_{OL} = 2.0$ V/0.8 V.
 9. t_{OFF} (Max.), t_{OEZ} (Max.), t_{SDZ} (Max.) and t_{SEZ} (Max.) define the time at which the outputs achieve the open circuit condition and are not reference to output voltage levels.
 10. Either t_{RCH} or t_{RRH} must be satisfied for a read cycle.
 11. These parameters are referenced to \overline{CAS} leading edge of early write cycles and to $\overline{WB}/\overline{WE}$ leading edge in \overline{OE} controlled write cycles and read modify write cycles.
 12. t_{WCS} , t_{RWD} , t_{CWD} and t_{AWD} are not restrictive operating parameters. They are included in the data sheet as electrical characteristics only.
 If $t_{WCS} \geq t_{WCS}$ (Min.), the cycle is an early write cycle, and the data out pin will remain open circuit (high impedance) throughout the entire cycle : If $t_{RWD} \geq t_{RWD}$ (Min.), $t_{CWD} \geq t_{CWD}$ (Min.) and $t_{AWD} \geq t_{AWD}$ (Min.) the cycle is a read-write cycle and the data out will contain data read from the selected cell : If neither of the above sets of conditions is satisfied, the condition of the data out (at access time) is indeterminate.
 13. Operation within the t_{RCD} (Max.) limit ensures that t_{RAC} (Max.) can be met. t_{RCD} (Max.) is specified as a reference point only : If t_{RCD} is greater than the specified t_{RCD} (Max.) limit, then access time is controlled by t_{CAC} .
 14. Operation within the t_{RAD} (Max.) limit ensures that t_{RAC} (Max.) can be met. t_{RAD} (Max.) is specified as a reference point only : If t_{RAD} is greater than the specified t_{RAD} (Max.) limit, then access time is controlled by t_{AA} .
 15. Input levels at the AC parameter measurement are 3.0 V/0 V.
 16. Stresses greater than those listed under "Absolute Maximum Ratings" may cause permanent damage to the device.
 17. All voltages are referenced to V_{SS} .

TIMING WAVEFORM

Read Cycle

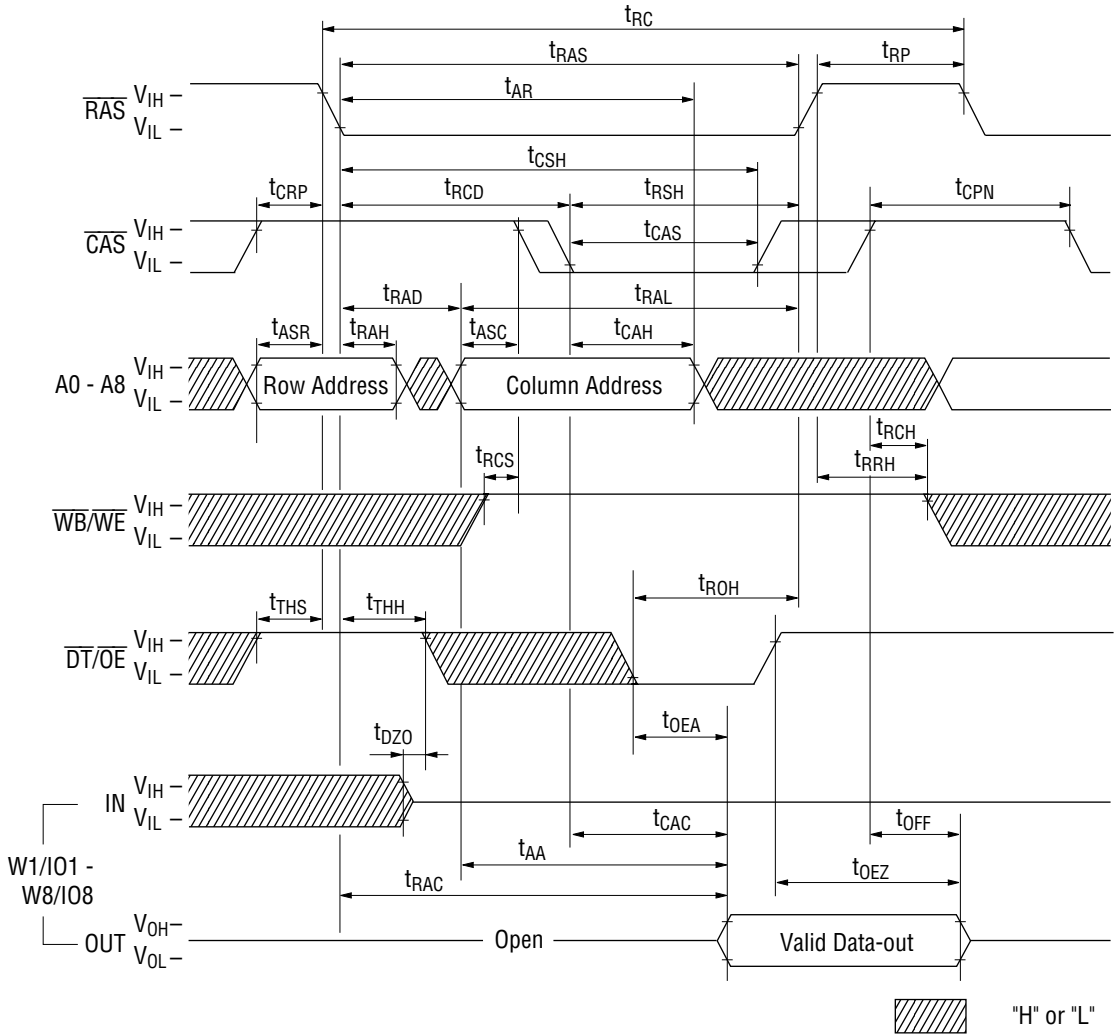

Write Cycle (Early Write)

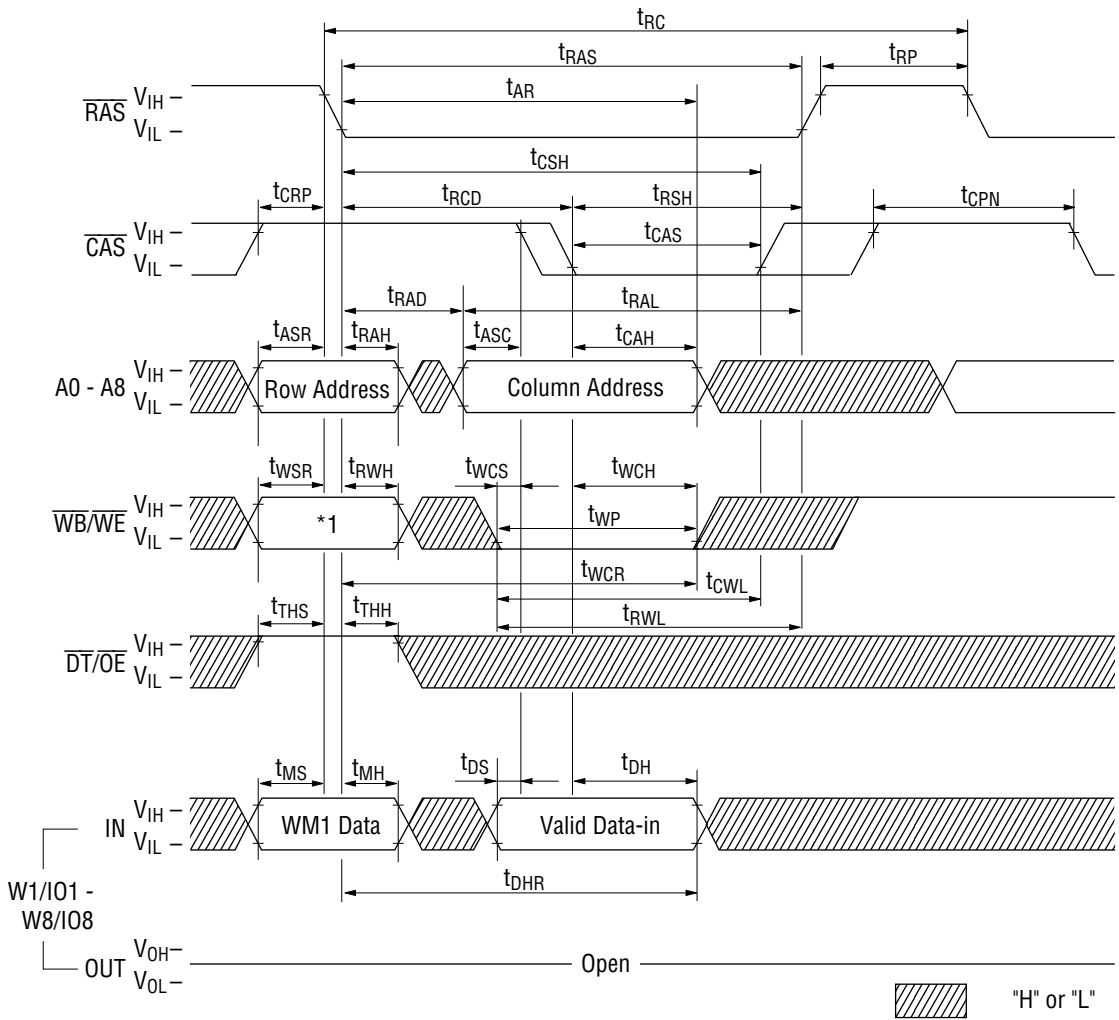

| *1 $\overline{\text{WB/WE}}$ | W1/IO1 - W8/IO8 | Cycle |
|------------------------------|-----------------|---------------|
| 0 | WM1 data | Write per Bit |
| 1 | Don't Care | Normal Write |

WM1 data: 0: Write Disable
1: Write Enable

Write Cycle (\overline{OE} Controlled Write)

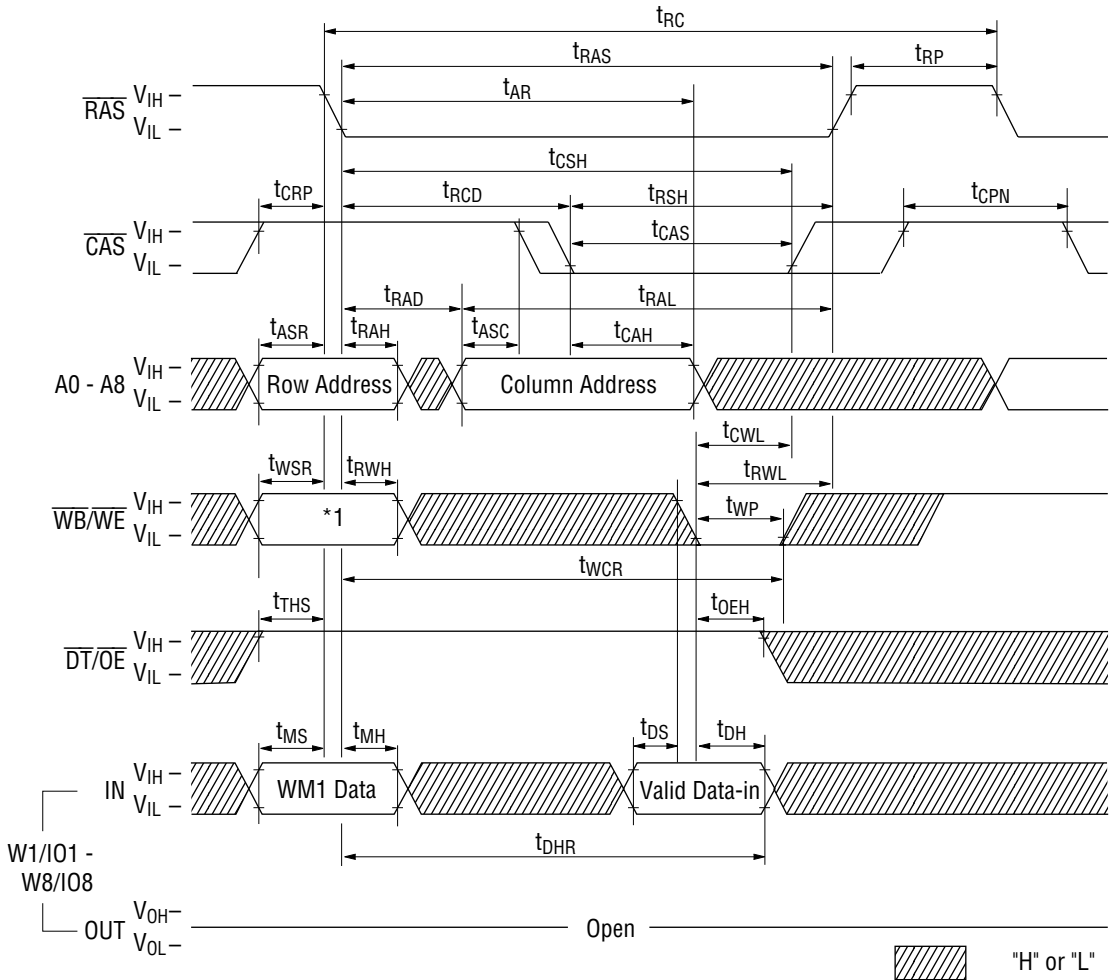

| *1 $\overline{WB}/\overline{WE}$ | W1/IO1 - W8/IO8 | Cycle |
|----------------------------------|-----------------|---------------|
| 0 | WM1 data | Write per Bit |
| 1 | Don't Care | Normal Write |

WM1 data: 0: Write Disable
1: Write Enable

Fast Page Mode Read Modify Write Cycle

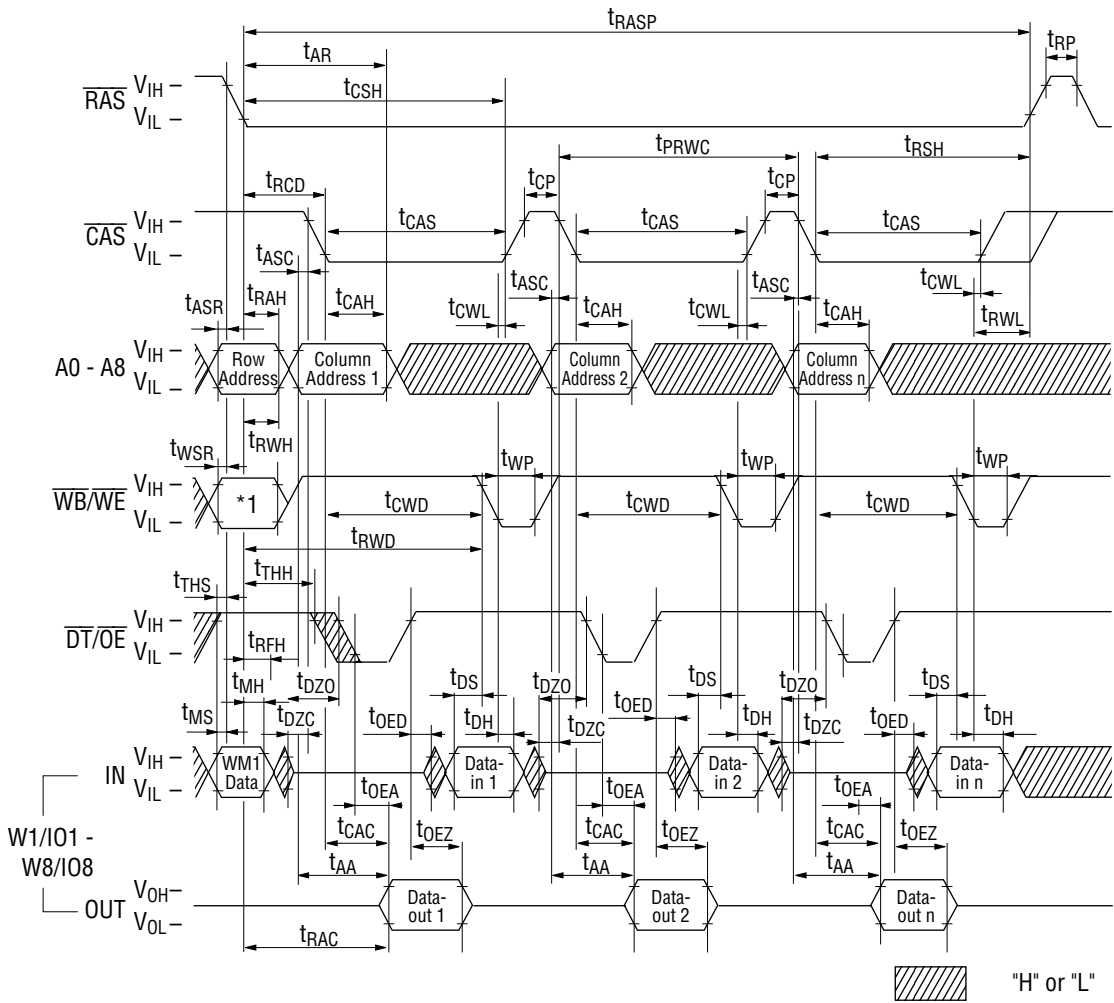

| *1 WB/WE | W1/IO1 - W8/IO8 | Cycle |
|----------|-----------------|---------------|
| 0 | WM1 data | Write per Bit |
| 1 | Don't Care | Normal Write |

WM1 data: 0: Write Disable
1: Write Enable

RAS Only Refresh Cycle

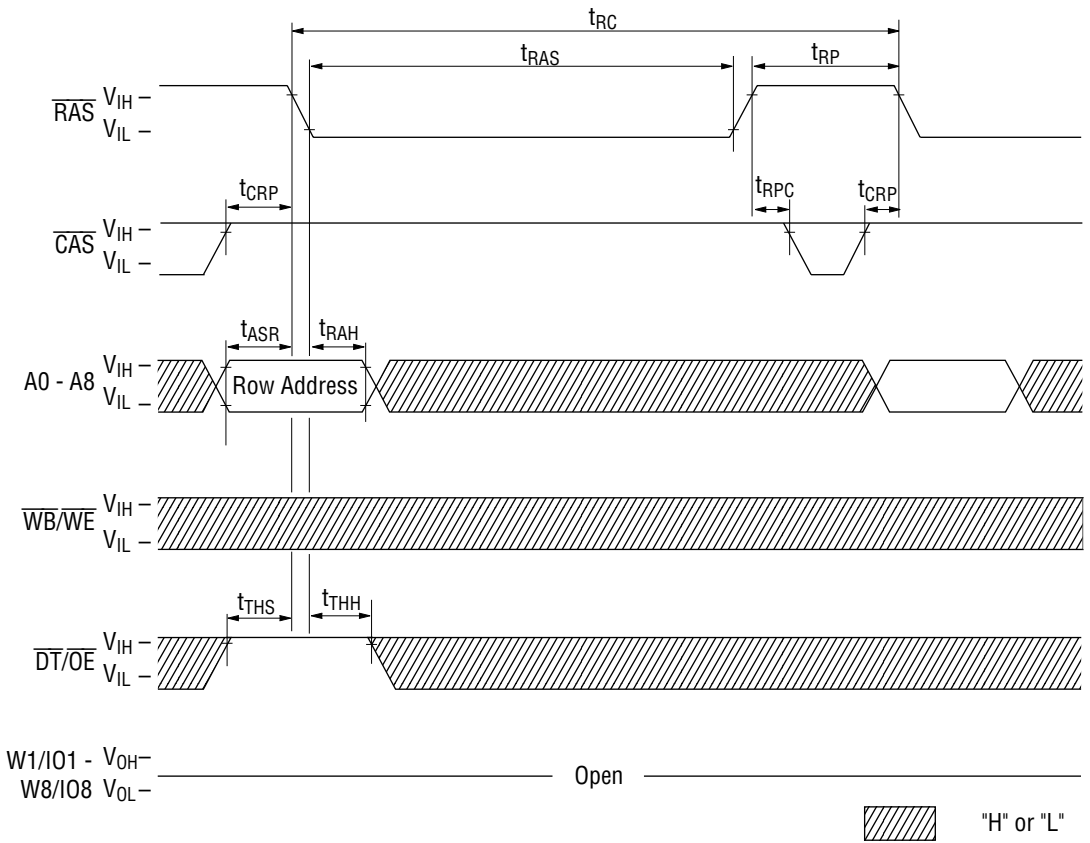

CAS before RAS Refresh Cycle

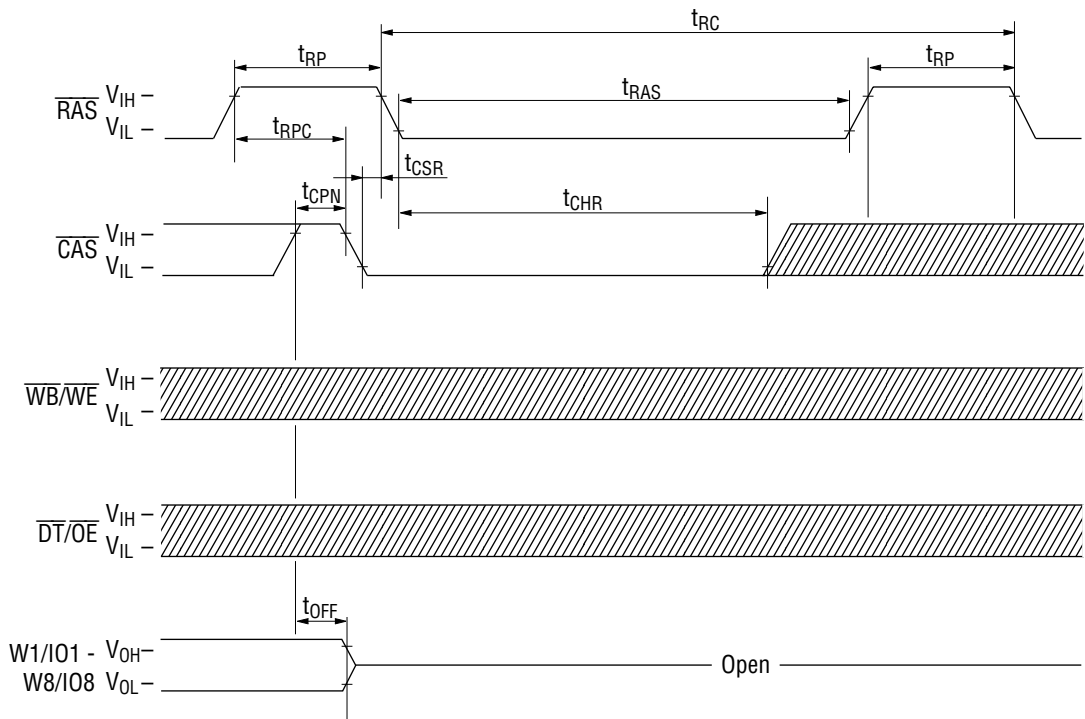

Note: A0 - A8 = Don't care ("H" or "L")  "H" or "L"

Hidden Refresh Cycle

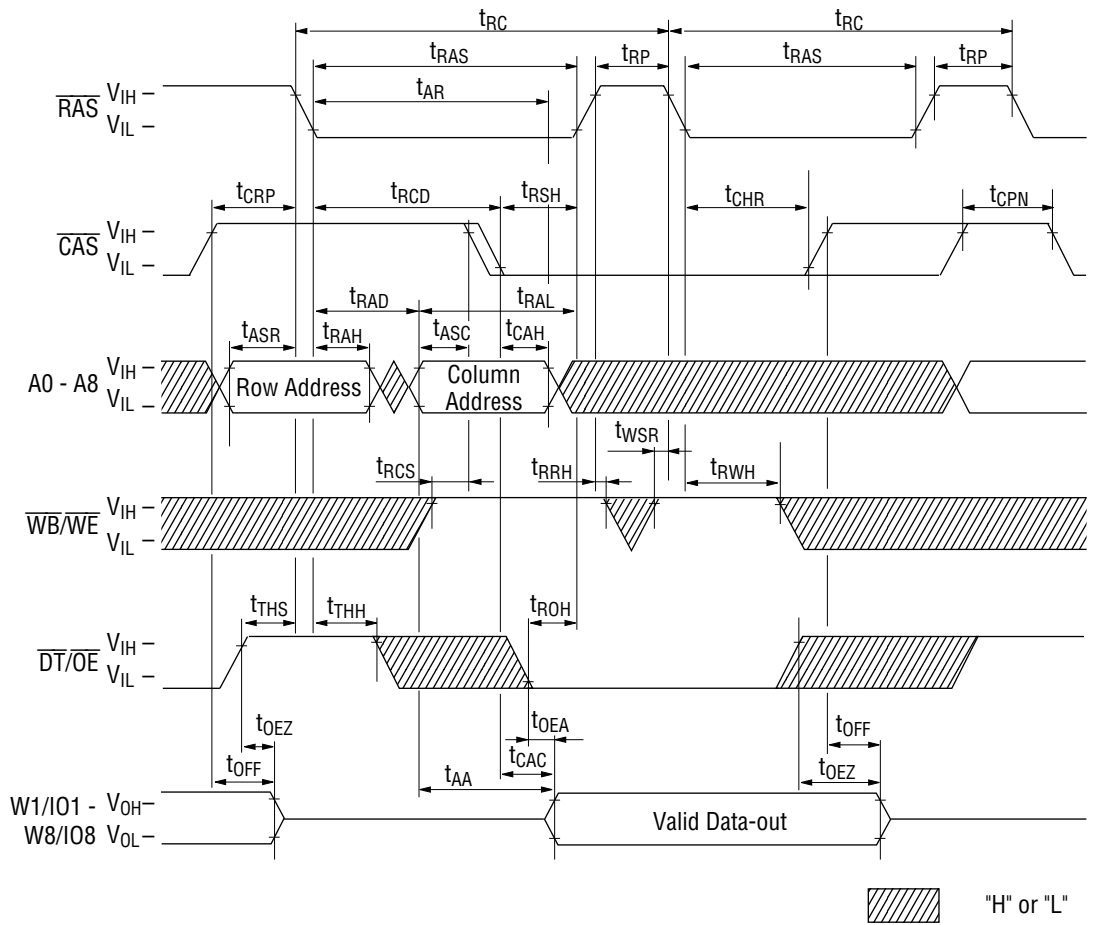

Read Transfer Cycle (Previous Transfer is Write Transfer Cycle)

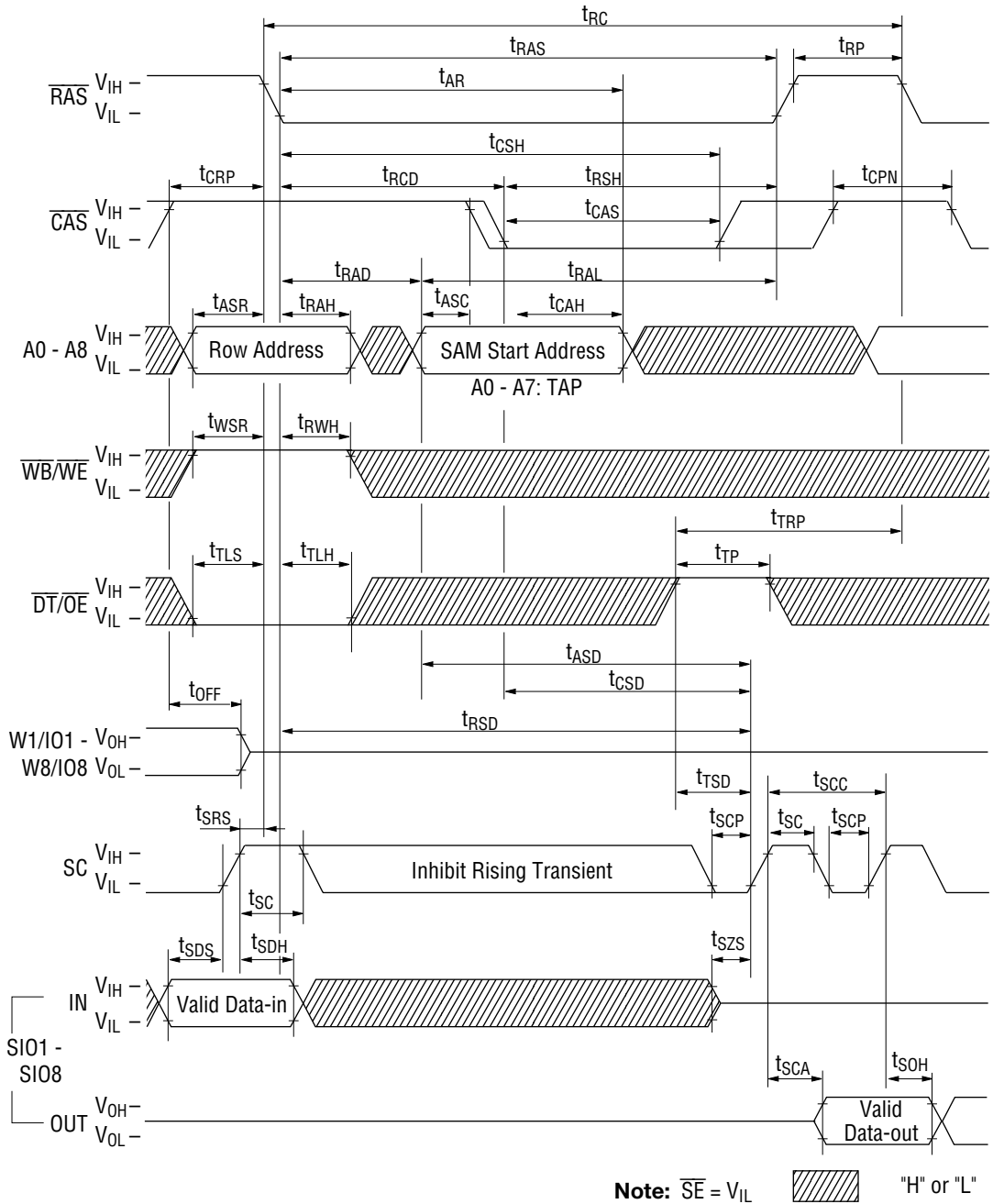

Real Time Read Transfer Cycle

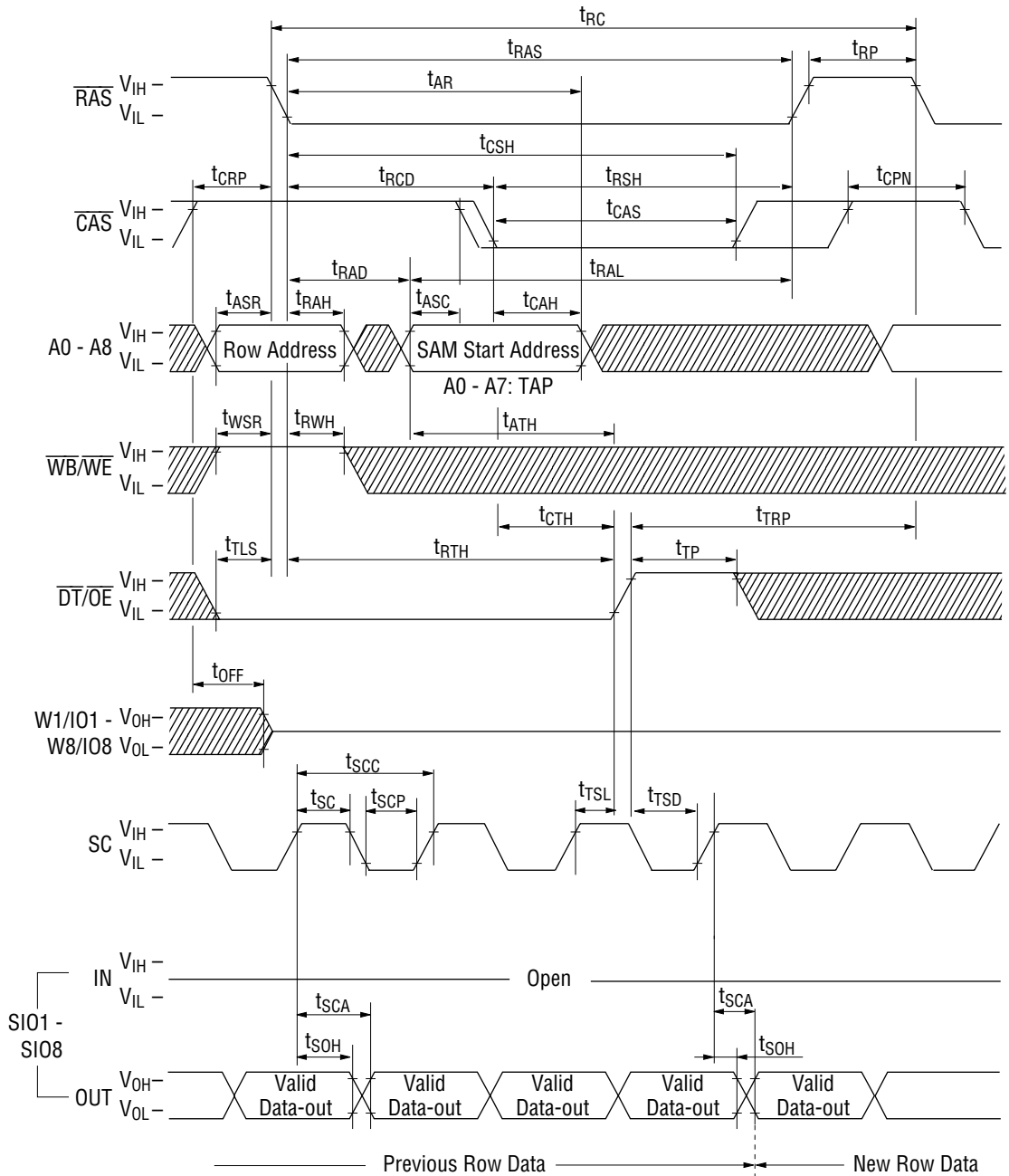

Note: $\overline{SE} = V_{IL}$  "H" or "L"

Pseudo Write Transfer Cycle

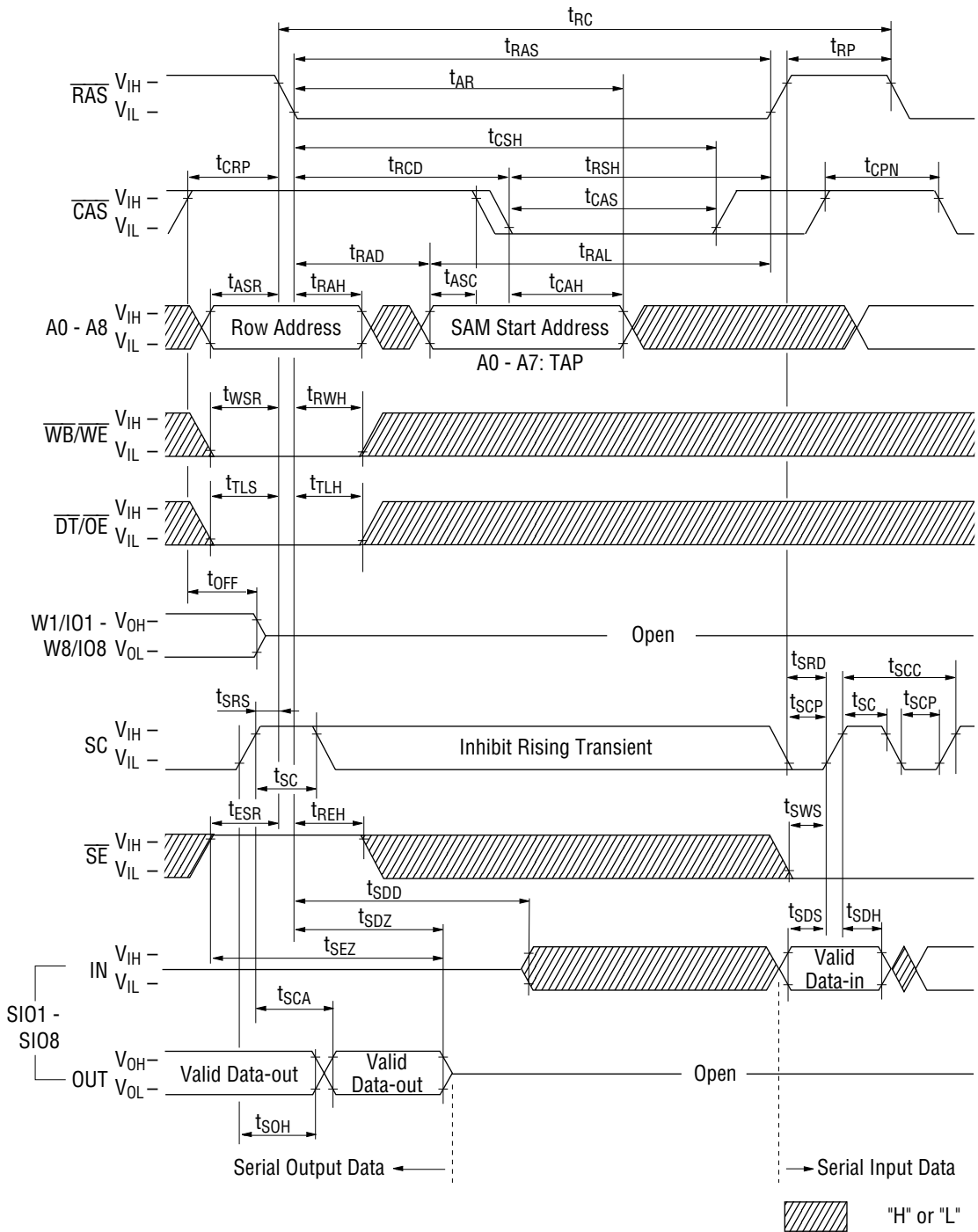

Write Transfer Cycle

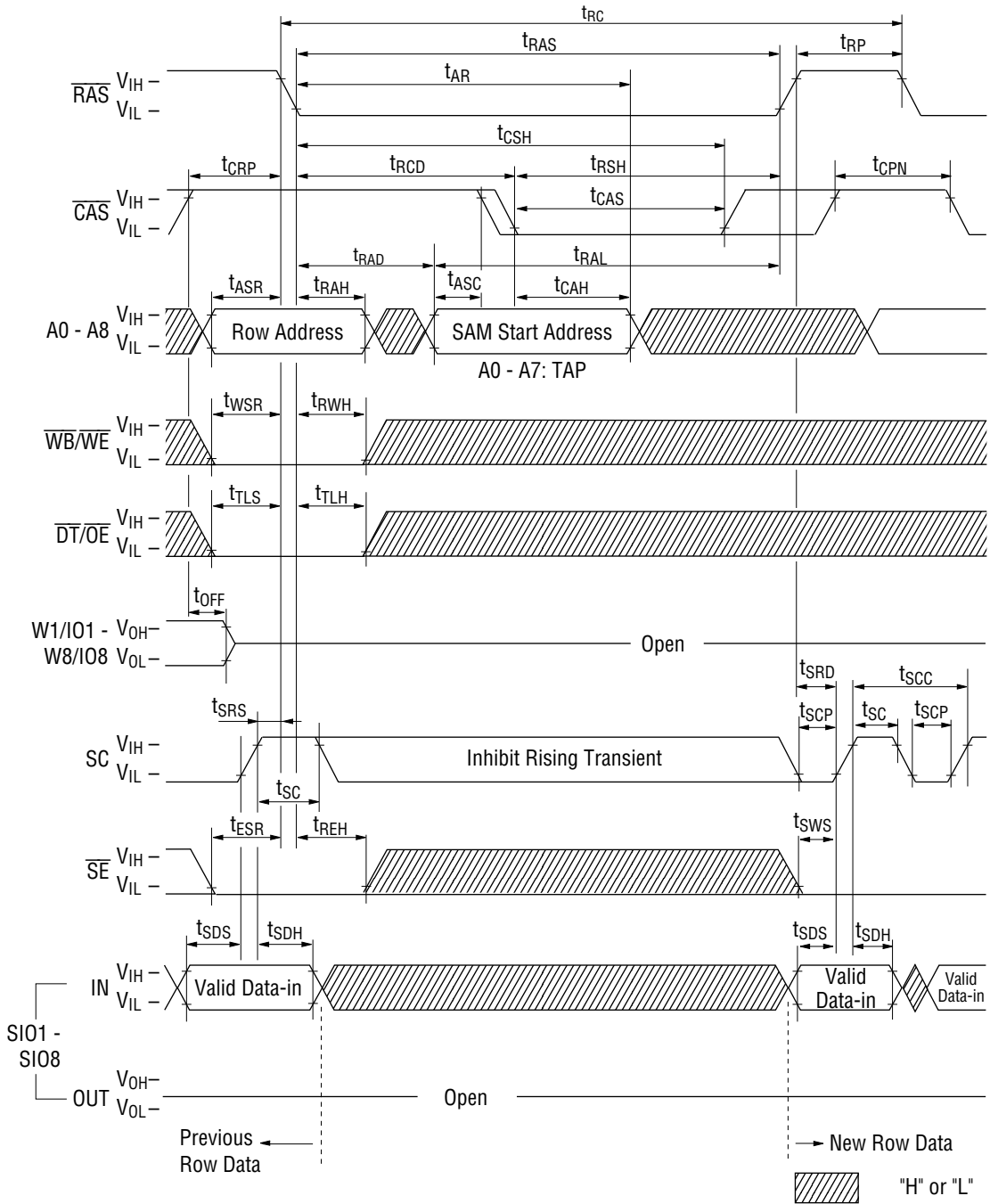

Serial Read Cycle ($\overline{SE} = V_{IL}$)

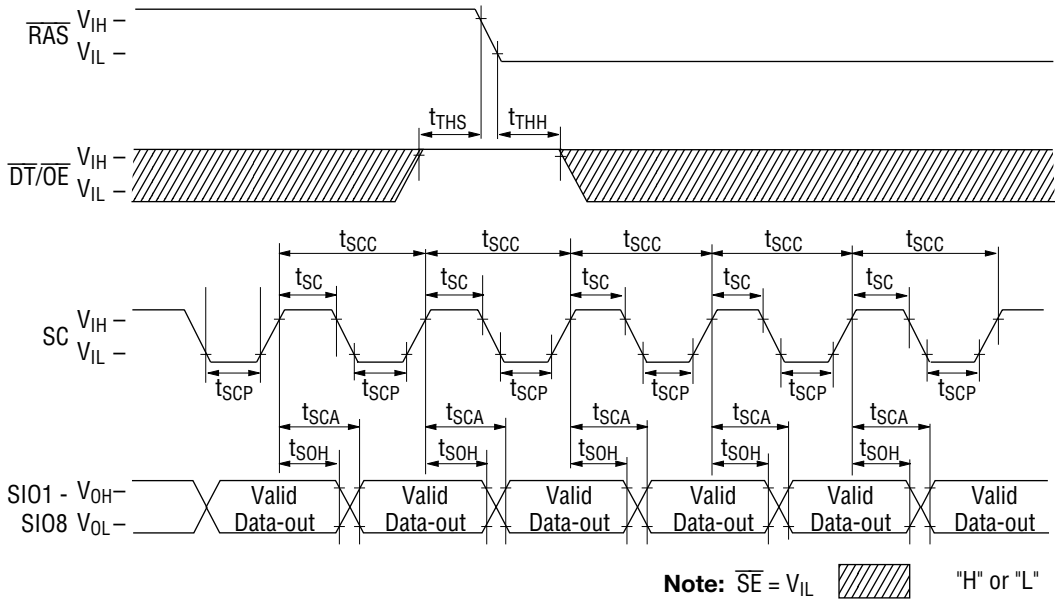

Serial Read Cycle (\overline{SE} Controlled Outputs)

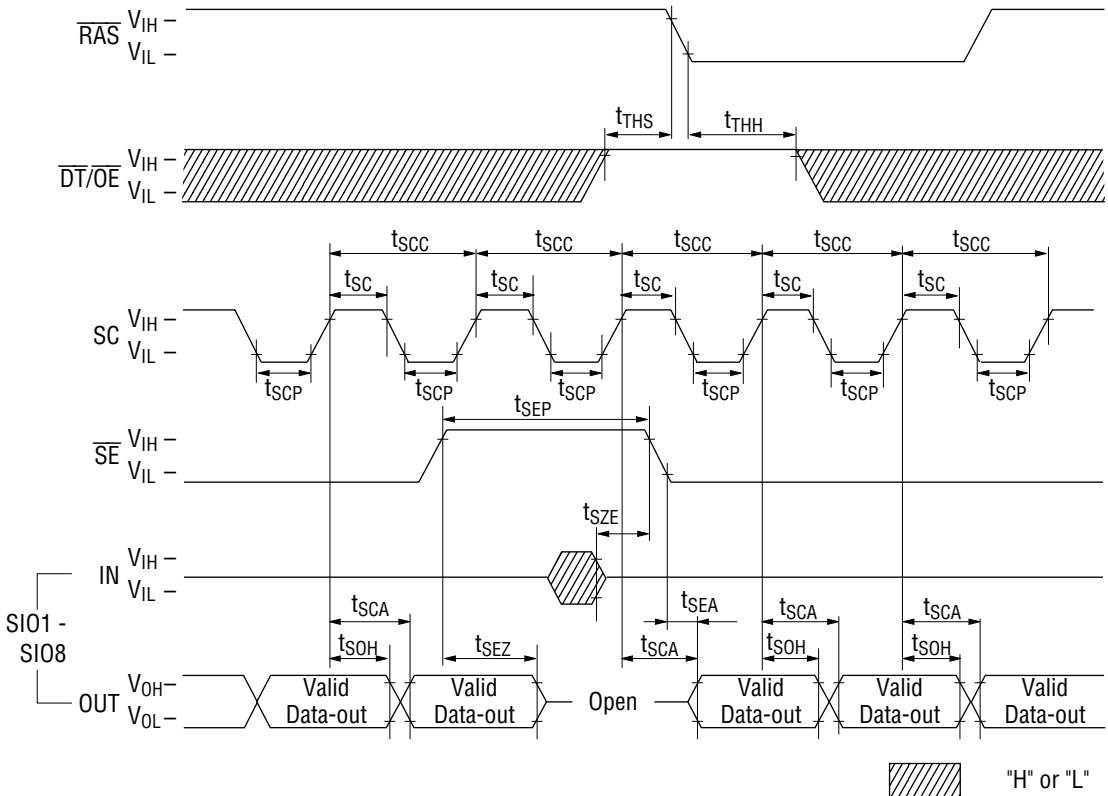

Address Input : A0 - A8

The 17 address bits decode an 8-bit location out of the 131,072 locations in the MSM518121A memory array. The address bits are multiplexed to 9 address input pins (A0 to A8) as standard DRAM. Nine row address bits are latched at the falling edge of $\overline{\text{RAS}}$. The following eight column address bits are latched at the falling edge of $\overline{\text{CAS}}$.

Row Address Strobe : $\overline{\text{RAS}}$

$\overline{\text{RAS}}$ is a basic a RAM control input signal. The RAM port is in standby mode when the $\overline{\text{RAS}}$ level is "high". As the standard DRAM's $\overline{\text{RAS}}$ signal function, $\overline{\text{RAS}}$ is the control input that latches the row address bits as a random access cycle begins at the falling edge of $\overline{\text{RAS}}$.

In addition to the conventional RAM signal functions, the level of the input signals, $\overline{\text{CAS}}$, $\overline{\text{DT}}/\overline{\text{OE}}$, $\overline{\text{WB}}/\overline{\text{WE}}$, and $\overline{\text{SE}}$, at the falling edge of $\overline{\text{RAS}}$, determines the MSM518121A operation modes.

Column Address Strobe : $\overline{\text{CAS}}$

As the standard DRAM's $\overline{\text{CAS}}$ signal function, $\overline{\text{CAS}}$ is the control input signal that latches the column address input and acts as an RAM port output enable signal.

Data Transfer / Output Enable : $\overline{\text{DT}}/\overline{\text{OE}}$

$\overline{\text{DT}}/\overline{\text{OE}}$ is also a control input signal having multiple functions. As the standard DRAM's $\overline{\text{OE}}$ signal function, $\overline{\text{DT}}/\overline{\text{OE}}$ is used as an output enable control when $\overline{\text{DT}}/\overline{\text{OE}}$ is "high" at the falling edge of $\overline{\text{RAS}}$.

In addition to the conventional $\overline{\text{OE}}$ signal function, a data transfer operation is started between the RAM port and the SAM port when the $\overline{\text{DT}}/\overline{\text{OE}}$ is "low" at the falling edge of $\overline{\text{RAS}}$.

Write-per-Bit / Write Enable : $\overline{\text{WB}}/\overline{\text{WE}}$

$\overline{\text{WB}}/\overline{\text{WE}}$ is a control input signal having multiple functions. As the standard DRAM's $\overline{\text{WE}}$ signal function, it is used to write data into the memory array on the RAM port when $\overline{\text{WB}}/\overline{\text{WE}}$ is "high" at the falling edge of $\overline{\text{RAS}}$.

In addition to the conventional $\overline{\text{WE}}$ signal function, the $\overline{\text{WB}}/\overline{\text{WE}}$ determines the write-per-bit function when $\overline{\text{WB}}/\overline{\text{WE}}$ is "low" at the falling edge of $\overline{\text{RAS}}$, during RAM port operations. The $\overline{\text{WB}}/\overline{\text{WE}}$ also determines the direction of data transfer between the RAM and SAM. When $\overline{\text{WB}}/\overline{\text{WE}}$ is "high" at the falling edge of $\overline{\text{RAS}}$, the data is transferred from RAM to SAM (Read transfer). When $\overline{\text{WB}}/\overline{\text{WE}}$ is "low" at the falling edge of $\overline{\text{RAS}}$, the data is transferred from SAM to RAM (Write transfer).

Write Mask Data / Data Input and Mask Data : W1 / IO1 - W8 / IO8

W1 / IO1 to W8 / IO8 have the functions of both Input/Output and a control input signal. As the standard DRAM's I/O pins, input data on the W1 / IO1 to W8 / IO8 are written into the RAM port during the write cycle. The input data is latched at the falling edge of either $\overline{\text{CAS}}$ or $\overline{\text{WB}}/\overline{\text{WE}}$, whichever occurs later. The RAM data out buffers, which will output read data from the W1 / IO1 to W8 / IO8 pins, become low impedance state after the specified access times from $\overline{\text{RAS}}$, $\overline{\text{CAS}}$, $\overline{\text{DT}}/\overline{\text{OE}}$ and column address are satisfied and the output data will remain valid as long as $\overline{\text{CAS}}$ and $\overline{\text{DT}}/\overline{\text{OE}}$ are kept "low". The outputs will return to the high-impedance state at the rising edge of either $\overline{\text{CAS}}$ or $\overline{\text{DT}}/\overline{\text{OE}}$, whichever occurs earlier.

In addition to the conventional I/O functions, the W1 / IO1 to W8 / IO8 have the function to set the mask data, which select mask input pins out of eight input pins, W1 / IO1 to W8 / IO8, at the falling edge of $\overline{\text{RAS}}$. Data is written in to the DRAM on data lines where the write-mask data is a logic "1". Writing is inhibited on data lines where the write-mask data is a logic "0". The write-mask data is valid for only one cycle.

Serial Clock : SC

SC is a main serial cycle control input signal. All operations of the SAM port are synchronized with the serial clock SC. Data is shifted in or out of the SAM registers at the rising edge of SC. In a serial read, the output data becomes valid on the SIO pins after the maximum specified serial access time t_{SCA} from the rising edge of SC.

The serial clock SC also increments the 8 bits serial pointer which is used to select the SAM address. The pointer address is incremented in a wrap-around mode to select sequential locations after the setting location which is determined by the column address in the read transfer cycle. When the pointer reaches the most significant address location (Decimal 255), the next SC clock will place it at the least significant address location (Decimal 0).

The serial clock SC must be held data constant V_{IH} or V_{IL} level during read/pseudo write/write transfer operations and should not be clocked while the SAM port is in the standby mode to prevent the SAM pointer from being incremented.

Serial Enable : $\overline{\text{SE}}$

The $\overline{\text{SE}}$ is a serial access enable control and serial read/write control input signal. In a serial read cycle, $\overline{\text{SE}}$ is used as an output control. In a serial write cycle, $\overline{\text{SE}}$ is used as a write enable control. When $\overline{\text{SE}}$ is "high", serial access is disabled, however, the serial address pointer location is still incremented when SC is clocked even when $\overline{\text{SE}}$ is "high".

Serial Input / Output : SIO1 - SIO8

Serial input/output mode is determined by the most recent read, write or pseudo write transfer cycle. When a read transfer cycle is performed, the SAM port is in the output mode. When a write or pseudo write transfer cycle is performed, the SAM port is switched from output mode to input mode.

Fast Page Mode Cycle

Fast page mode allows data to be transferred into or out multiple column locations of the same row by performing multiple $\overline{\text{CAS}}$ cycle during a single active $\overline{\text{RAS}}$ cycle.

During a fast page cycle, the $\overline{\text{RAS}}$ signal may be maintained active for a period up to 100 μ seconds.

For the initial fast page mode access, the output data is valid after the specified access times from $\overline{\text{RAS}}$, $\overline{\text{CAS}}$, column address and $\overline{\text{DT/OE}}$.

For all subsequent fast page mode read operations, the output data is valid after the specified access times from $\overline{\text{CAS}}$, column address and $\overline{\text{DT/OE}}$. When the write-per-bit function is enabled, the mask data latched at the falling edge of $\overline{\text{RAS}}$ is maintained throughout the fast page mode write or Read-Modify-Write cycle.

$\overline{\text{RAS}}$ -Only Refresh

The data in the DRAM requires periodic refreshing to prevent data loss. Refreshing is accomplished by performing a memory cycle at each of the 512 rows in the DRAM array within the specified 8 ms refresh period.

Although any normal memory cycle will perform the refresh operation, this function is most easily accomplished with " $\overline{\text{RAS}}$ -Only" cycle.

$\overline{\text{CAS}}$ before $\overline{\text{RAS}}$ Refresh

The MSM518121A also offers an internal-refresh function. When $\overline{\text{CAS}}$ is held "low" for a specified period (t_{CSR}) before $\overline{\text{RAS}}$ goes "low", an internal refresh address counter and on-chip refresh control clock generators are enabled and an internal refresh operation takes place.

When the refresh operation is completed, the internal refresh address counter is automatically incremented in preparation for the next $\overline{\text{CAS}}$ -before- $\overline{\text{RAS}}$ cycle. For successive $\overline{\text{CAS}}$ -before- $\overline{\text{RAS}}$ refresh cycle, $\overline{\text{CAS}}$ can remain "low" while cycling $\overline{\text{RAS}}$.

Hidden Refresh

A hidden refresh is a $\overline{\text{CAS}}$ -before- $\overline{\text{RAS}}$ refresh performed by holding $\overline{\text{CAS}}$ "low" from a previous read cycle. This allows for the output data from the previous memory cycle to remain valid while performing a refresh.

The internal refresh address counter provides the address and the refresh is accomplished by cycling $\overline{\text{RAS}}$ after the specified $\overline{\text{RAS}}$ -precharge period.

Write-per-Bit Function

The Write-Per-Bit selectively controls the internal write-enable circuits of the RAM port. Write-Per-Bit is enabled when $\overline{\text{WB/WE}}$ held "low" at the falling edge of $\overline{\text{RAS}}$ in a random write operation. Also, at the falling edge of $\overline{\text{RAS}}$, the mask data on the Wi/IOi pins are latched into a write mask register. The write mask data must be presented at the Wi/IOi pins at every falling edge of $\overline{\text{RAS}}$. A "0" on any of the Wi/IOi pins will disable the corresponding write circuits and new data will not be written into the RAM. A "1" on any of the Wi/IOi pins will enable the corresponding write circuits and new data will be written into the RAM.

DATA TRANSFER OPERATION

The MSM518121A features an internal data transfer capability between RAM and the SAM. During a transfer cycle, 256 words by 8 bits of data can be loaded from RAM to SAM (Read Transfer) or from SAM to RAM (Write Transfer).

The MSM518121A supports three types of transfer operations: Read transfer, Write Transfer and pseudo write transfer. Data transfer operations between RAM and SAM are invoked by holding the $\overline{DT}/\overline{OE}$ signal "low" at the falling edge of \overline{RAS} , the type of data transfer operation is determined by the state of \overline{CAS} , $\overline{WB}/\overline{WE}$ and \overline{SE} latched at the falling edge of \overline{RAS} .

During data transfer operations, the SAM port is switched from input to output mode (Read Transfer) or output to input mode (Write Transfer/Pseudo Write Transfer).

During a data transfer cycle, the row A0-A8 select one of the 512 rows of the memory array to or from which data will be transferred and the column address A0-A8 select one of the tap locations in the serial register. The selected tap location is the start position in the SAM port from which the first serial data will be read out during the subsequent serial read cycle or the start position in the SAM port into which the first serial data will be written during the subsequent serial write cycle.

Read Transfer Cycle

A read transfer consists of loading a selected row of data from the RAM array into the SAM register. A read transfer is invoked by holding \overline{CAS} "high", $\overline{DT}/\overline{OE}$ "low" and $\overline{WB}/\overline{WE}$ "high" at the falling edge of \overline{RAS} . The row address selected at the falling edge of \overline{RAS} determines the RAM row to be transferred into the SAM.

The transfer cycle is completed at the rising edge of $\overline{DT}/\overline{OE}$. When the transfer is completed, the SAM port is set into the output mode.

In a read/real time read transfer of a new row of data is completed at the rising edge of $\overline{DT}/\overline{OE}$ and this data becomes valid on the SIO lines after the specified access time t_{SCA} from the rising edge of the subsequent serial clock (SC) cycle. The start address of the serial pointer of the SAM is determined by the column address selected at the falling edge of \overline{CAS} .

In a read transfer cycle preceded by a write transfer cycle, the SC clock must be held at a constant V_{IL} or V_{IH} after the SC high time has been satisfied. A rising edge of the SC clock must not occur until after the specified delay t_{TSD} from the rising edge of $\overline{DT}/\overline{OE}$.

In a real time read transfer cycle (which is preceded by another read transfer cycle), the previous row data appears on the SIO lines until the $\overline{DT}/\overline{OE}$ signal goes "high" and the serial access time t_{SCA} for the following serial clock is satisfied.

This feature allows for the first bit of the new row of data to appear on the serial output as soon as the last bit of the previous row has been strobed without any timing loss. To make this continuous data flow possible, the rising edge of $\overline{DT}/\overline{OE}$ must be synchronized with \overline{RAS} , \overline{CAS} and the subsequent rising edge of SC (t_{RTH} , t_{CTH} , and t_{TSL}/t_{TSD} must be satisfied). The timing restriction t_{TSL}/t_{TSD} are 5 ns min./10 ns min..

Write Transfer Cycle

A write transfer cycle transfers the contents of the SAM register into a selected row of the RAM array. If the SAM data to be transferred must first be loaded through the SAM port, a pseudo write transfer operation must precede the write transfer cycles.

Data transferred to SAM by read transfer cycle can be written to other address of RAM by write transfer cycle.

A write transfer is invoked by holding $\overline{\text{CAS}}$ "low", $\overline{\text{WB}}/\overline{\text{WE}}$ "low" and $\overline{\text{SE}}$ "low" at the falling edge of $\overline{\text{RAS}}$.

The row address selected at the falling edge of $\overline{\text{RAS}}$ determines the RAM row address into which the data will be transferred. The column address selected at the falling edge of $\overline{\text{CAS}}$ determines the start address of the serial pointer of the SAM.

After the writettransfer is completed, the SIO lines are set in the input mode so that serial data synchronized with the SC clock can be loaded.

When consecutive write transfer operations are performed, new data must not be written into the serial register until the $\overline{\text{RAS}}$ cycle of the preceding write transfer is completed.

Consequently, the SC clock must be held at a constant V_{IL} or V_{IH} during the $\overline{\text{RAS}}$ cycle. A rising edge of the SC clock is only allowed after the specified delay t_{SRD} from the rising edge of $\overline{\text{RAS}}$, at which time a new row of data can be written in the serial register.

Pseudo Write Transfer Cycle

A pseudo write transfer cycle must be performed before loading data into the serial register after a read transfer operation has been excuted. The only purpose of a pseudo write transfer is to change the SAM port mode from output mode to input mode (A data transfer from SAM to RAM does not occur).

After the serial register is loaded with new data, a write transfer cycle must be performed to transfer the data from SAM to RAM. A pseudo write transfer is invoked by holding $\overline{\text{CAS}}$ "high", DT/OE "low", $\overline{\text{WB}}/\overline{\text{WE}}$ "low" and $\overline{\text{SE}}$ "high" at the falling edge of $\overline{\text{RAS}}$. The timing conditions are the same as the one for the write transfer cycle except for the state of $\overline{\text{SE}}$ at the falling edge of $\overline{\text{RAS}}$.

Transfer Operation Without $\overline{\text{CAS}}$

During all transfer cycles, the $\overline{\text{CAS}}$ input clock must be cycled, so that the column address are latched at the falling edge of $\overline{\text{CAS}}$, to set the SAM tap location. If $\overline{\text{CAS}}$ was maintained at a constant "high" level during a transfer cycle, the SAM pointer location would be undifined. Therefore a transfer cycle with $\overline{\text{CAS}}$ held "high" is not allowed.

Normal Read Transfer Cycle After Normal Read Transfer Cycle

Another read transfer may be performed following the read transfer provided that a minimum delay of 30 ns from the rising edge of the first clock SC is satisfied.

POWER-UP

Power must be applied to the $\overline{\text{RAS}}$ and $\overline{\text{DT}}/\overline{\text{OE}}$ input signals to pull them "high" before or at the same time as the V_{CC} supply is turned on. After power-up, a pause of 200 μ seconds (minimum) is required with $\overline{\text{RAS}}$ and $\overline{\text{DT}}/\overline{\text{OE}}$ held "high".

After the pause, a minimum of 8 $\overline{\text{RAS}}$ and 8 SC dummy cycles must be performed to stabilize the internal circuitry, before valid read, write or transfer operations can begin. During the initialization period, the $\overline{\text{DT}}/\overline{\text{OE}}$ signal must be held "high". If the internal refresh counter is used, a minimum 8 $\overline{\text{CAS}}$ -before- $\overline{\text{RAS}}$ initialization cycles are required instead of 8 $\overline{\text{RAS}}$ cycle.

Initial State After Power-up

When power is achieved with $\overline{\text{RAS}}$, $\overline{\text{CAS}}$, $\overline{\text{DT}}/\overline{\text{OE}}$ and $\overline{\text{WB}}/\overline{\text{WE}}$ held "high" the internal state of the MSM518121A is automatically set as follows.

| | | |
|---------------------|-------|------------|
| SAM port | ————> | Input mode |
| Write mask register | ————> | Write mode |
| TAP pointer | ————> | Invalid |

However, the initial state can not be guaranteed for various power-up conditions and input signal levels. Therefore, it is recommended that the initial state be set after the initialization of the device is performed (200 μ seconds pause followed by a minimum of 8 $\overline{\text{RAS}}$ cycles and 8 SC cycles) and before valid operations begin.

(Unit : mm)

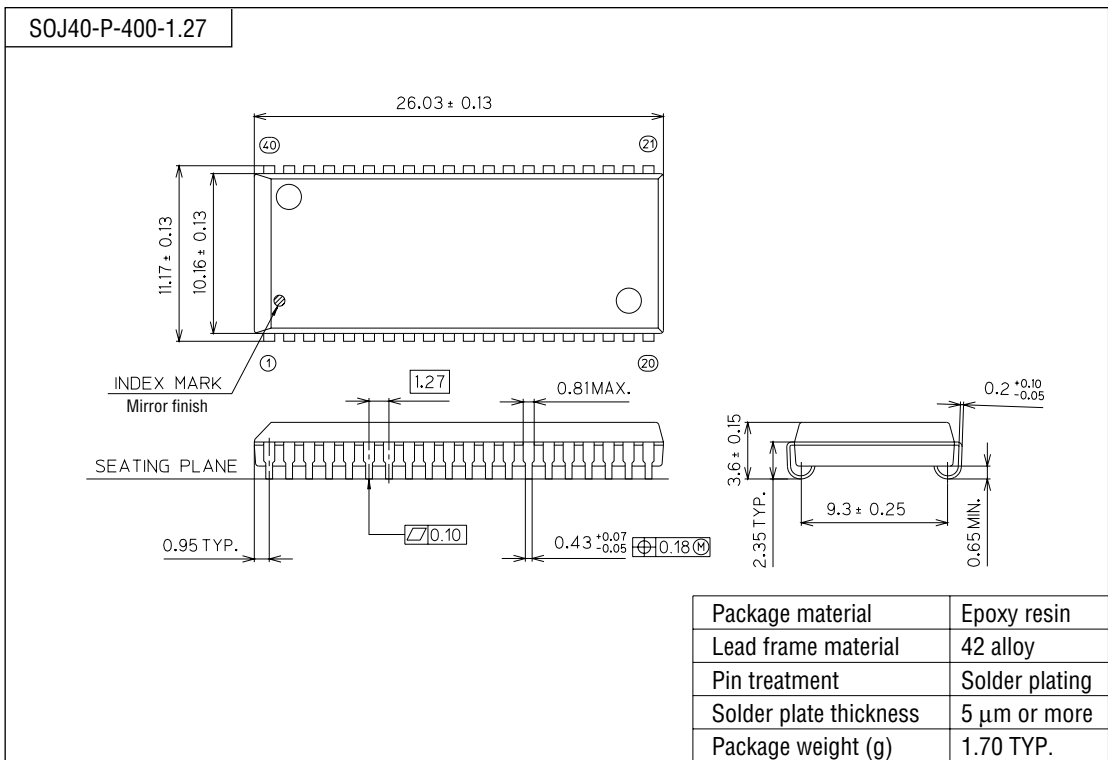

Notes for Mounting the Surface Mount Type Package

The SOP, QFP, TSOP, SOJ, QFJ (PLCC), SHP and BGA are surface mount type packages, which are very susceptible to heat in reflow mounting and humidity absorbed in storage. Therefore, before you perform reflow mounting, contact Oki's responsible sales person for the product name, package name, pin number, package code and desired mounting conditions (reflow method, temperature and times).