

# T-1 3/4 ( f5mm) HIGH POWER AlInGaP LED LAMPs

## MVL-584SO

### Description

The MVL-584SO utilizes the latest absorbing substrate Aluminum Indium Gallium Phosphide (AlInGaP) LED technology. This LED material has outstanding light output efficiency over a wide range of drive current. The package is T-1 3/4 (5mm) water clear standard type.

### Package Dimensions

Unit: mm ( inches )

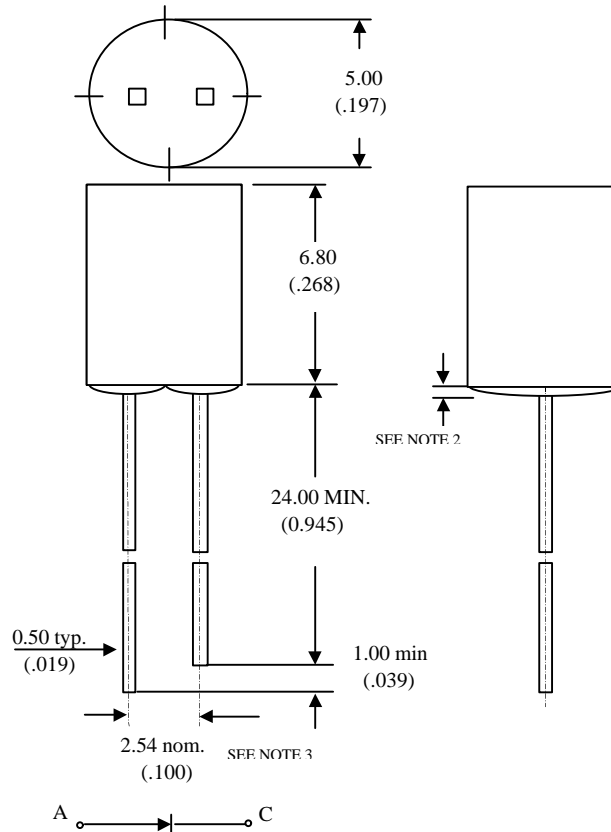

### Features

- Ultra - brightness
- Low power consumption
- TTL compatible
- Reliable

#### Notes :

1. Tolerance is  $\pm 0.25$  mm (.010") unless otherwise noted.
2. Protruded resin under flange is 1.5 mm (.059") max.
3. Lead spacing is measured where the leads emerge from the package.

### Absolute Maximum Ratings

@  $T_A = 25^\circ\text{C}$

Parameter	Maximum Rating	Unit
Power Dissipation	125	mW
Peak Forward Current(1/10 Duty Cycle 100 $\mu$ s pulse width )	100	mA
Continuous Forward Current	50	mA
Reverse Voltage	5	V
Operating Temperature Range	-40 $^\circ\text{C}$ to +100 $^\circ\text{C}$	
Storage Temperature Range	-40 $^\circ\text{C}$ to +100 $^\circ\text{C}$	
Lead Soldering Temperature 1.6 mm from body for 5 seconds at 260 $^\circ\text{C}$		

**UNI**

Unity Opto Technology Co., Ltd.

09/05/2000

## Optical-Electrical Characteristics

@ T<sub>A</sub>=25°C

Parameter	Test Conditions	Symbol	Min .	Typ .	Max .	Unit .
Luminous Intensity	I <sub>F</sub> =20mA	I <sub>V</sub>	-	1300	-	mcd
Forward Voltage	I <sub>F</sub> =20mA	V <sub>F</sub>	-	1.9	2.5	V
Reverse Current	V <sub>R</sub> =5V	I <sub>R</sub>	-	-	100	μA
Peak / Dominant Wavelength	I <sub>F</sub> =20mA	λ <sub>p</sub> /λ <sub>d</sub>	-	610/605	-	nm
Spectral Line Half Width	I <sub>F</sub> =20mA	Δλ	-	20	-	nm
Viewing Angle	I <sub>F</sub> =20mA	2θ <sub>1/2</sub>	-	75	-	deg.

## Typical Optical-Electrical Characteristic Curves

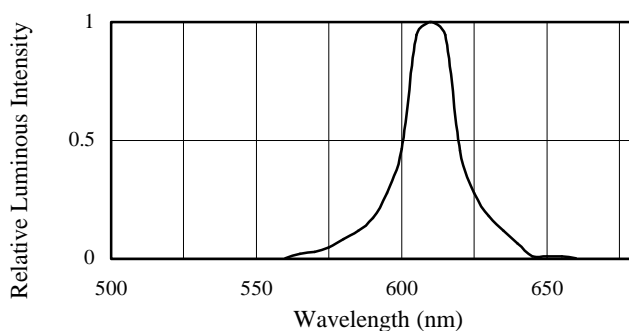

FIG.1 SPECTRAL DISTRIBUTION

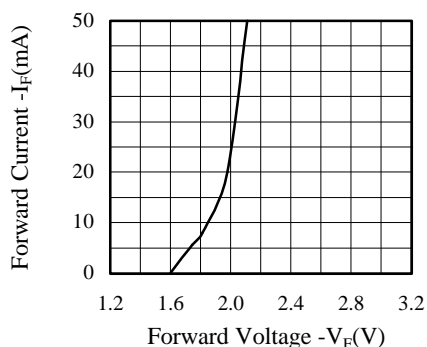

FIG.2 FORWARD CURRENT VS. FORWARD VOLTAGE

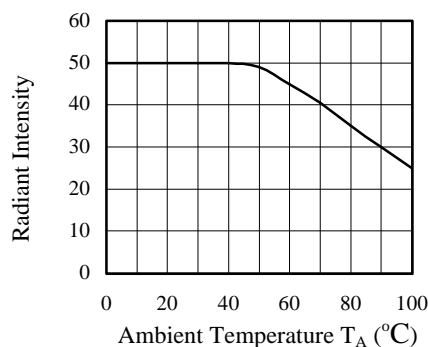

FIG.3 FORWARD CURRENT VS. AMBIENT TEMPERATURE

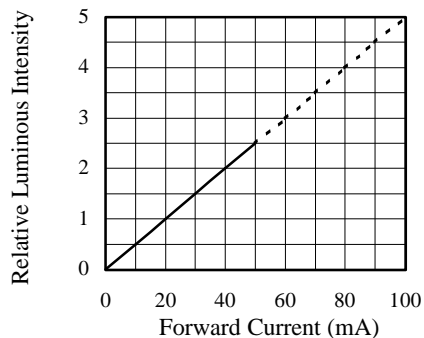

FIG.4 RELATIVE LUMINOUS INTENSITY VS. FORWARD CURRENT

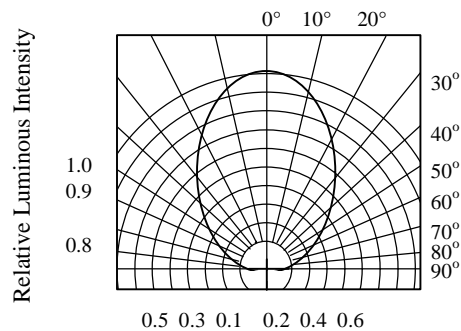

FIG.5 RADIATION DIAGRAM