

# Specification

\_\_\_\_\_ Co., Ltd.

Name of products

Model

High output type Hall Element

N H E 5 2 0

Acceptance of client      Please send back 2 sets of this specification  
with your signature for acceptance

Date  
30th Nov.2001

NIPPON CERAMIC CO.,LTD

APPROVED BY

CHECKED BY

1 . Absolute Maximum Ratings

( T a = 2 5 )

Item	Symbol	Rating	Unit
Max.Control current	I c max	2 0	m A
Max.Power dissipation	P d	1 5 0	m W
Operating temp.	T o p r	- 2 0 ~ + 1 0 0	
Storage temp.	T s t g	- 4 0 ~ + 1 1 0	

2 . Electrical Characteristics

( T a = 2 5 )

Item	Symbol	Condition	Min	Standard	Max	Unit
Hall voltage	VH	V c = 1 V , B = 5 0 0 G	1 2 0		3 2 0	m V
Residual voltage	V o	V c = 1 V , B = 0 G			± 7	m V
Input resistance	R i n	I = 1 m A , B = 0 G	2 4 0		5 5 0	
Output resistance	R o u t	I = 1 m A , B = 0 G	2 4 0		5 5 0	
Temp.coeff.of VH		T a = - 2 0 ~ + 1 0 0			- 2	%/
Temp.coeff.of resistance		T a = - 2 0 ~ + 1 0 0			- 2	%/

$$VH = VHM - Vo$$

VHM : Measured value of Hall voltage at 500 gauss  
 V o : Residual voltage

3 . Classification of rank for Hall voltage and indication on print

Classification of rank for Hall voltage

VH ( m V )	Name of Rank	Printing
1 9 2 ~ 2 3 5	5	I F 5
2 2 5 ~ 2 7 5	6	I F 6
2 6 5 ~ 3 2 0	7	I F 7

Indication of model(Rank)

N H E 5 2 0 - ( is showing name of Rank)

4 . Guaranteed condition on mounting of mini-mould package

- ( 1 ) . Commendable condition of soldering to substrate
  - 1 ) Please avoid rapid heating and rapid cooling to main body.
  - 2 ) Please do preliminary heating for 2~3 min.at 130 ~ 150
  - 3 ) Best condition of soldering(example:reflow)is done for 3~5sec.at 230 ~ 250
- ( 2 ) . The way of soldering and guaranteed temperature
  - 1 ) The way of soldering

Method	Explanation of method	Temp.
Reflow	Soldering is done in high temp.circumstances.	350 within 3 sec
Solder dip	Soldering is done in dipping sink of solder.	350 within 3 sec
Soldering Iron	Repair soldering part of lead wire by soldering iron.	3 5 0 within 3 sec.

2 ) Range of guaranteed temp.

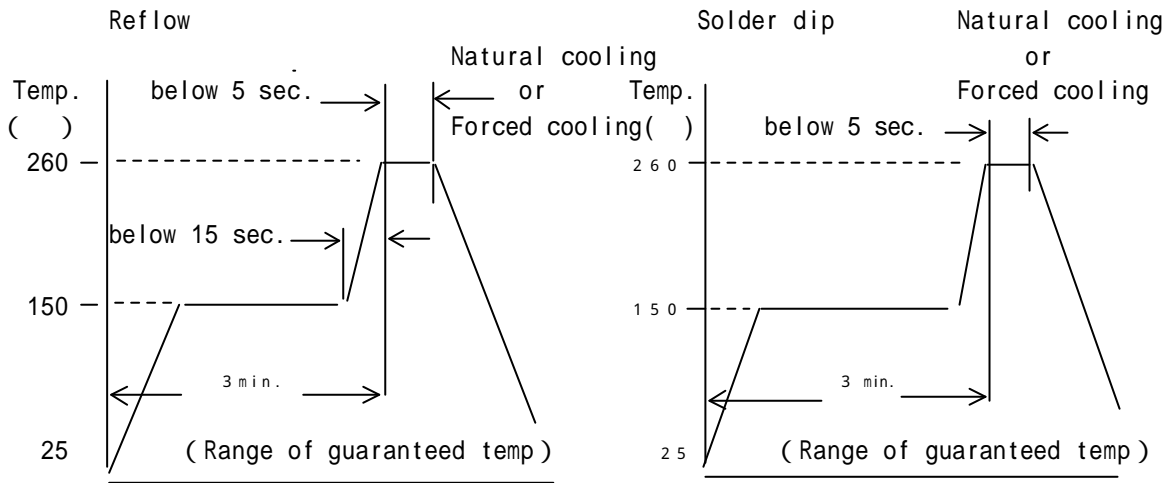

Guaranteed Value (at highest temp.)

Method	Reflow	Dip
Temp	2 6 0	2 6 0
Hour	5 sec	5 sec

5 . Shipping Condition

( 1 ) . Structure of taping

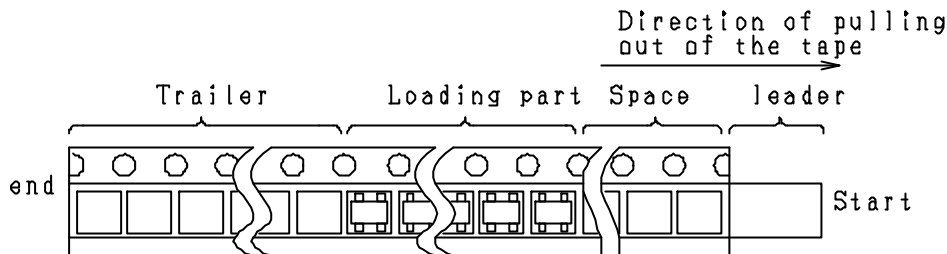

- ( 1 ) - 1 . There is printed side of Hall element on the side of cover tape.  
Hall element is put in the tape matching with the direction of pulling out of the tape and long handed side of Hall element.  
It doesn't matter the direction of Hall element itself.
- ( 1 ) - 2 . It needs over 4cm of the space before and behind the tape,so does the part of trailer.

( 2 ) . Mechanical strength and handling

- ( 2 ) - 1 . The exfoliate strength of covertape is 10 ~ 90g

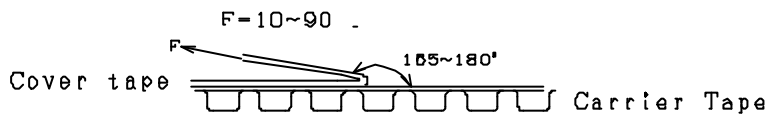

- ( 2 ) - 2 . Even though tape is curved by radius 15mm, the product doesn't jump out.
- ( 2 ) - 3 . The product doesn't stick on the cover tape.
- ( 2 ) - 4 . It is stored in the place where its temperature below 40 and humidity below 80%. It should not be stored to expose to the direct rays of sun.
- ( 2 ) - 5 . It should not have missing one consecutively in the tape.
- ( 2 ) - 6 . It should not have any joint on the tape.

( 3 ) . Packing

- ( 3 ) - 1 . It is put 3,000pcs of Hall element in 1 reel.
- ( 3 ) - 2 . It is put 5 rolls of reel(15,000pcs)in small carton box.
- ( 3 ) - 3 . It is put 6 small carton boxes(90,000pcs)in big carton box.

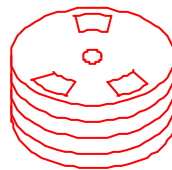
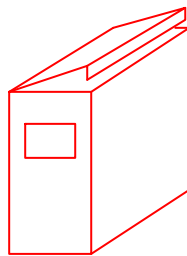

Note:Piling reels and put 5reels in the small box

6 . Outline drawing of Hall Element [Unit : mm]

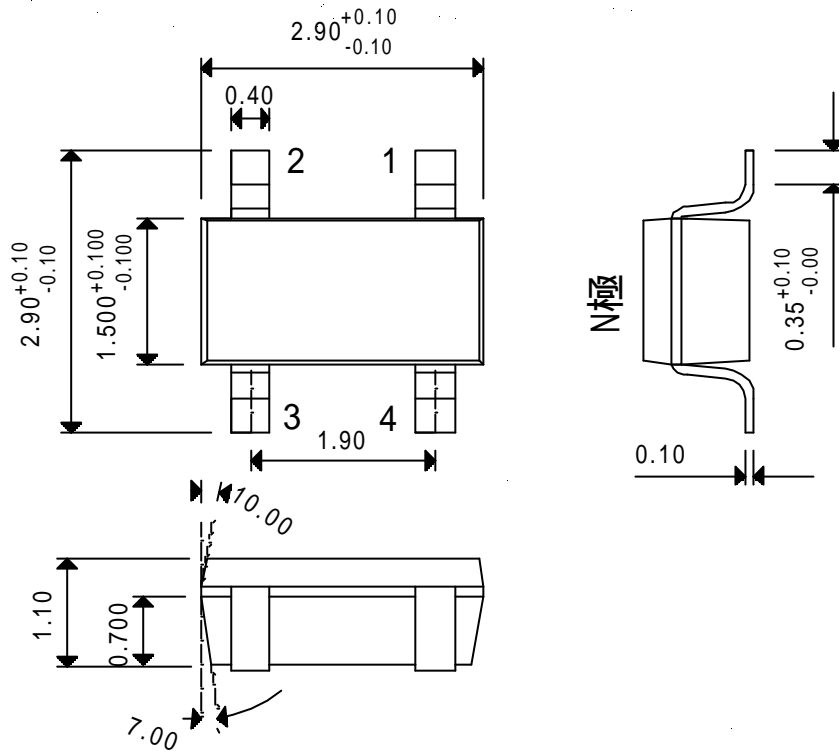

Terminal	
Input	1(±):3(±)
Output	2(±):4(±)

7 . printing

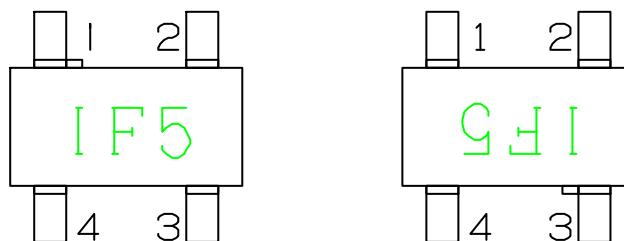

8 . Outline drawing of carrier tape [Unit : mm]

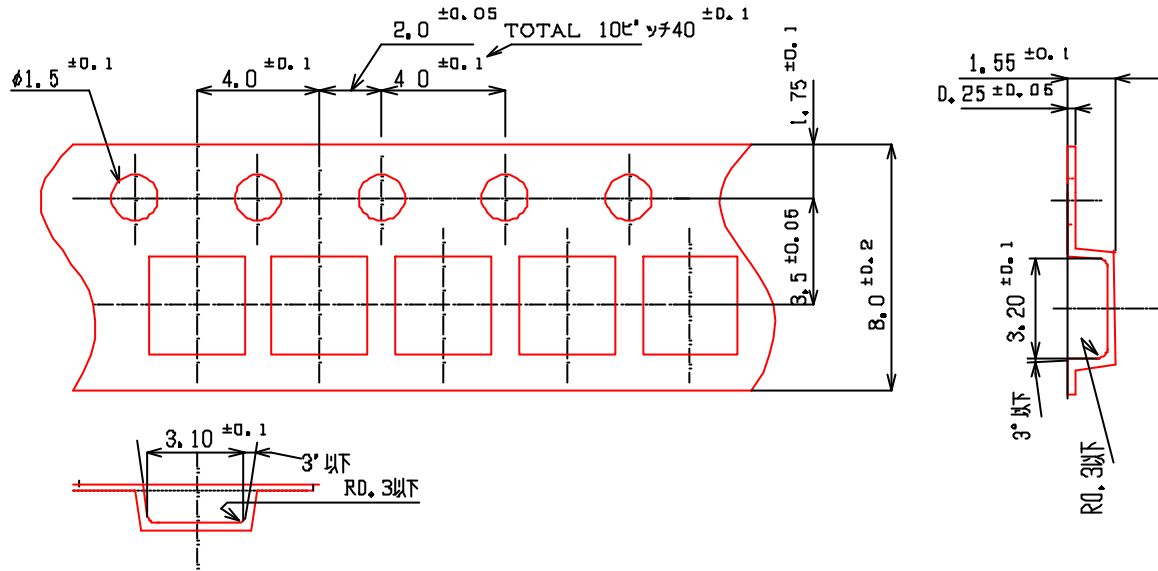

9 . Outline drawing of reel [Unit : mm]

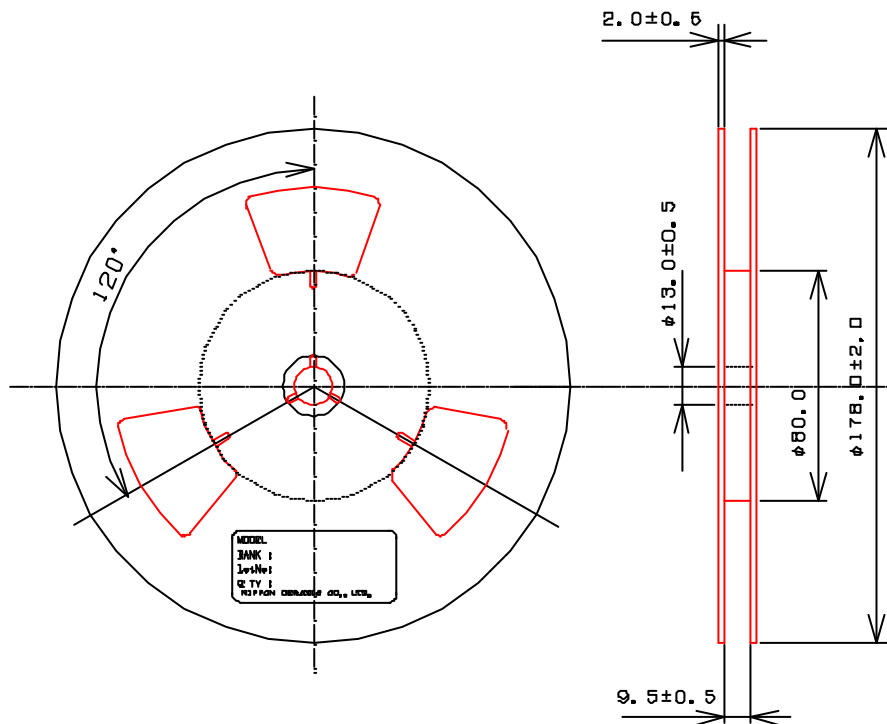

1 0 . The matters that demand special attention

( 1 ) . Attention for storage

Because the shipment is done by taping method, it is required paying most attention on circumstances for its storage as we are mentioning on section 5. To store the products under the following circumstances and corresponding to those situation, will cause damage of appearance, defectiveness of characteristics and inferior of structure etc.

It needs your understandings about fully cares for the storage.

And our recommendable circumstance is to keep them in N2-Box.

a . Circumstances under high temperature, high humidity for long hours.

b . Circumstances that has corrosive gas, organic gas, acidity and alkalinity background.

c . Circumstances that has many dust.

( 2 ) . Attention for mounting

Please follow the matters as we mentioned on section 4.

( 3 ) . Notice

This specification certifies the quality of Hall element itself.

However, it is beyond the limits of the subject of guarantee under the following condition.

a . When it is done inappropriate handling by user, or is used in the wrong way.

b . When it is done additional treatment by others ( except supplier.)

C . When it has situation like natural disaster etc that Nicera doesnot have responsibility.

The limit of guarantee on this specification means the guarantee of replacement for Hall element itself.

The expenses for exchange, damage caused by inferior and trouble of Supplies, are not included. Your understanding and cooperation is highly appreciated.