

■ PAD COORDINATES 1

Chip Size 22070μm x 2550μm (Chip Center 0μm x 0μm)

PAD No.	Terminal	X(μm)	Y(μm)	PAD No.	Terminal	X(μm)	Y(μm)	PAD No.	Terminal	X(μm)	Y(μm)
1	DMY ₀	-10642.5	-1090.0	52	D ₁₀	-5584.5	-1090.0	103	V _{4A2}	-292.0	-1090.0
2	DMY ₁	-10599.5	-1090.0	53	D ₁₀	-5511.5	-1090.0	104	V _{SSA}	-182.5	-1090.0
3	DMY ₂	-10556.5	-1090.0	54	D ₁₁	-5365.5	-1090.0	105	V _{SSA}	-109.5	-1090.0
4	V _{SSA}	-10475.5	-1090.0	55	D ₁₁	-5292.5	-1090.0	106	V _{LCD}	0.0	-1090.0
5	V _{SSA}	-10402.5	-1090.0	56	D ₁₂	-5146.5	-1090.0	107	V _{LCD}	73.0	-1090.0
6	SEL68	-10293.0	-1090.0	57	D ₁₂	-5073.5	-1090.0	108	V _{LCD}	146.0	-1090.0
7	SEL68	-10220.0	-1090.0	58	D ₁₃	-4927.5	-1090.0	109	V _{LCD}	219.0	-1090.0
8	V _{DDA}	-10110.5	-1090.0	59	D ₁₃	-4854.5	-1090.0	110	V _{LCD}	292.0	-1090.0
9	V _{DDA}	-10037.5	-1090.0	60	D ₁₄	-4708.5	-1090.0	111	V _{LCD}	365.0	-1090.0
10	P/S	-9928.0	-1090.0	61	D ₁₄	-4635.5	-1090.0	112	V ₁	511.0	-1090.0
11	P/S	-9855.0	-1090.0	62	D ₁₅	-4489.5	-1090.0	113	V ₁	584.0	-1090.0
12	V _{SSA}	-9745.5	-1090.0	63	D ₁₅	-4416.5	-1090.0	114	V ₁	657.0	-1090.0
13	V _{SSA}	-9672.5	-1090.0	64	V _{DD}	-4197.5	-1090.0	115	V ₁	730.0	-1090.0
14	RESb	-9563.0	-1090.0	65	V _{DD}	-4124.5	-1090.0	116	V ₁	803.0	-1090.0
15	RESb	-9490.0	-1090.0	66	V _{DD}	-4051.5	-1090.0	117	V ₁	876.0	-1090.0
16	DMY ₃	-9380.5	-1090.0	67	V _{DD}	-3978.5	-1090.0	118	V ₂	1022.0	-1090.0
17	CSb	-9271.0	-1090.0	68	V _{DD}	-3905.5	-1090.0	119	V ₂	1095.0	-1090.0
18	CSb	-9198.0	-1090.0	69	V _{DD}	-3832.5	-1090.0	120	V ₂	1168.0	-1090.0
19	DMY ₄	-9088.5	-1090.0	70	V _{DD}	-3759.5	-1090.0	121	V ₂	1241.0	-1090.0
20	RS	-8979.0	-1090.0	71	CL	-3613.5	-1090.0	122	V ₂	1314.0	-1090.0
21	RS	-8906.0	-1090.0	72	CL	-3540.5	-1090.0	123	V ₂	1387.0	-1090.0
22	DMY ₅	-8796.5	-1090.0	73	FLM	-3394.5	-1090.0	124	V ₃	1533.0	-1090.0
23	WRb	-8687.0	-1090.0	74	FLM	-3321.5	-1090.0	125	V ₃	1606.0	-1090.0
24	WRb	-8614.0	-1090.0	75	FR	-3175.5	-1090.0	126	V ₃	1679.0	-1090.0
25	DMY ₆	-8504.5	-1090.0	76	FR	-3102.5	-1090.0	127	V ₃	1752.0	-1090.0
26	RDb	-8395.0	-1090.0	77	CLK	-2956.5	-1090.0	128	V ₃	1825.0	-1090.0
27	RDb	-8322.0	-1090.0	78	CLK	-2883.5	-1090.0	129	V ₃	1898.0	-1090.0
28	V _{DDA}	-8212.5	-1090.0	79	OSC ₁	-2701.0	-1090.0	130	V ₄	2044.0	-1090.0
29	V _{DDA}	-8139.5	-1090.0	80	OSC ₁	-2628.0	-1090.0	131	V ₄	2117.0	-1090.0
30	D ₀ /SCL	-7993.5	-1090.0	81	OSC ₂	-2409.0	-1090.0	132	V ₄	2190.0	-1090.0
31	D ₀ /SCL	-7920.5	-1090.0	82	OSC ₂	-2336.0	-1090.0	133	V ₄	2263.0	-1090.0
32	D ₁ /SDA	-7774.5	-1090.0	83	V _{SS}	-2044.0	-1090.0	134	V ₄	2336.0	-1090.0
33	D ₁ /SDA	-7701.5	-1090.0	84	V _{SS}	-1971.0	-1090.0	135	V ₄	2409.0	-1090.0
34	D ₂	-7555.5	-1090.0	85	V _{SS}	-1898.0	-1090.0	136	V _{REG}	2555.0	-1090.0
35	D ₂	-7482.5	-1090.0	86	V _{SS}	-1825.0	-1090.0	137	V _{REG}	2628.0	-1090.0
36	D ₃ /SMODE	-7336.5	-1090.0	87	V _{SS}	-1752.0	-1090.0	138	V _{REG}	2701.0	-1090.0
37	D ₃ /SMODE	-7263.5	-1090.0	88	V _{SS}	-1679.0	-1090.0	139	V _{REG}	2774.0	-1090.0
38	D ₄ /SPOL	-7117.5	-1090.0	89	V _{SS}	-1606.0	-1090.0	140	V _{REG}	2847.0	-1090.0
39	D ₄ /SPOL	-7044.5	-1090.0	90	V _{1A1}	-1460.0	-1090.0	141	V _{REG}	2920.0	-1090.0
40	D ₅	-6898.5	-1090.0	91	V _{1A1}	-1387.0	-1090.0	142	V _{REF}	3029.5	-1090.0
41	D ₅	-6825.5	-1090.0	92	V _{DDA}	-1277.5	-1090.0	143	V _{REF}	3102.5	-1090.0
42	D ₆	-6679.5	-1090.0	93	V _{DDA}	-1204.5	-1090.0	144	V _{REF}	3175.5	-1090.0
43	D ₆	-6606.5	-1090.0	94	V _{1A2}	-1095.0	-1090.0	145	V _{REF}	3248.5	-1090.0
44	D ₇	-6460.5	-1090.0	95	V _{1A2}	-1022.0	-1090.0	146	V _{REF}	3321.5	-1090.0
45	D ₇	-6387.5	-1090.0	96	V _{SSA}	-912.5	-1090.0	147	V _{REF}	3394.5	-1090.0
46	V _{SSA}	-6241.5	-1090.0	97	V _{SSA}	-839.5	-1090.0	148	V _{BA}	3504.0	-1090.0
47	V _{SSA}	-6168.5	-1090.0	98	V _{4A1}	-730.0	-1090.0	149	V _{BA}	3577.0	-1090.0
48	D ₈	-6022.5	-1090.0	99	V _{4A1}	-657.0	-1090.0	150	V _{BA}	3650.0	-1090.0
49	D ₈	-5949.5	-1090.0	100	V _{DDA}	-547.5	-1090.0	151	V _{BA}	3723.0	-1090.0
50	D ₉	-5803.5	-1090.0	101	V _{DDA}	-474.5	-1090.0	152	V _{BA}	3796.0	-1090.0
51	D ₉	-5730.5	-1090.0	102	V _{4A2}	-365.0	-1090.0	153	V _{BA}	3869.0	-1090.0

■ PAD COORDINATES 2

Chip Size 22070μm x 2550μm (Chip Center 0μm x 0μm)

PAD No.	Terminal	X(μm)	Y(μm)	PAD No.	Terminal	X(μm)	Y(μm)	PAD No.	Terminal	X(μm)	Y(μm)
154	V _{SSH}	4051.5	-1090.0	205	C ₃₋	8212.5	-1090.0	256	DMY ₂₈	10845.0	-107.5
155	V _{SSH}	4124.5	-1090.0	206	C ₃₋	8285.5	-1090.0	257	DMY ₂₉	10845.0	-64.5
156	V _{SSH}	4197.5	-1090.0	207	C ₃₋	8358.5	-1090.0	258	DMY ₃₀	10845.0	-21.5
157	V _{SSH}	4270.5	-1090.0	208	C ₃₋	8431.5	-1090.0	259	DMY ₃₁	10845.0	21.5
158	V _{SSH}	4343.5	-1090.0	209	C ₃₋	8504.5	-1090.0	260	DMY ₃₂	10845.0	64.5
159	V _{SSH}	4416.5	-1090.0	210	C ₃₋	8577.5	-1090.0	261	DMY ₃₃	10845.0	107.5
160	V _{SSH}	4489.5	-1090.0	211	C ₄₊	8687.0	-1090.0	262	DMY ₃₄	10845.0	150.5
161	V _{OUT}	4672.0	-1090.0	212	C ₄₊	8760.0	-1090.0	263	COM ₆₃	10845.0	193.5
162	V _{OUT}	4745.0	-1090.0	213	C ₄₊	8833.0	-1090.0	264	COM ₆₂	10845.0	236.5
163	V _{OUT}	4818.0	-1090.0	214	C ₄₊	8906.0	-1090.0	265	COM ₆₁	10845.0	279.5
164	V _{OUT}	4891.0	-1090.0	215	C ₄₊	8979.0	-1090.0	266	COM ₆₀	10845.0	322.5
165	V _{OUT}	4964.0	-1090.0	216	C ₄₊	9052.0	-1090.0	267	COM ₅₉	10845.0	365.5
166	V _{OUT}	5037.0	-1090.0	217	C ₄₋	9161.5	-1090.0	268	COM ₅₈	10845.0	408.5
167	V _{OUT}	5110.0	-1090.0	218	C ₄₋	9234.5	-1090.0	269	COM ₅₇	10845.0	451.5
168	V _{EE}	5292.5	-1090.0	219	C ₄₋	9307.5	-1090.0	270	COM ₅₆	10845.0	494.5
169	V _{EE}	5365.5	-1090.0	220	C ₄₋	9380.5	-1090.0	271	COM ₅₅	10845.0	537.5
170	V _{EE}	5438.5	-1090.0	221	C ₄₋	9453.5	-1090.0	272	COM ₅₄	10845.0	580.5
171	V _{EE}	5511.5	-1090.0	222	C ₄₋	9526.5	-1090.0	273	COM ₅₃	10845.0	623.5
172	V _{EE}	5584.5	-1090.0	223	C ₅₊	9636.0	-1090.0	274	COM ₅₂	10845.0	666.5
173	V _{EE}	5657.5	-1090.0	224	C ₅₊	9709.0	-1090.0	275	COM ₅₁	10845.0	709.5
174	V _{EE}	5730.5	-1090.0	225	C ₅₊	9782.0	-1090.0	276	COM ₅₀	10845.0	752.5
175	C ₁₊	5840.0	-1090.0	226	C ₅₊	9855.0	-1090.0	277	DMY ₃₅	10845.0	795.5
176	C ₁₊	5913.0	-1090.0	227	C ₅₊	9928.0	-1090.0	278	DMY ₃₆	10845.0	838.5
177	C ₁₊	5986.0	-1090.0	228	C ₅₊	10001.0	-1090.0	279	DMY ₃₇	10845.0	881.5
178	C ₁₊	6059.0	-1090.0	229	C ₅₋	10110.5	-1090.0	280	DMY ₃₈	10642.5	1085.0
179	C ₁₊	6132.0	-1090.0	230	C ₅₋	10183.5	-1090.0	281	DMY ₃₉	10599.5	1085.0
180	C ₁₊	6205.0	-1090.0	231	C ₅₋	10256.5	-1090.0	282	DMY ₄₀	10556.5	1085.0
181	C ₁₋	6314.5	-1090.0	232	C ₅₋	10329.5	-1090.0	283	COM ₄₉	10513.5	1085.0
182	C ₁₋	6387.5	-1090.0	233	C ₅₋	10402.5	-1090.0	284	COM ₄₈	10470.5	1085.0
183	C ₁₋	6460.5	-1090.0	234	C ₅₋	10475.5	-1090.0	285	COM ₄₇	10427.5	1085.0
184	C ₁₋	6533.5	-1090.0	235	DMY ₇	10556.5	-1090.0	286	COM ₄₆	10384.5	1085.0
185	C ₁₋	6606.5	-1090.0	236	DMY ₈	10599.5	-1090.0	287	COM ₄₅	10341.5	1085.0
186	C ₁₋	6679.5	-1090.0	237	DMY ₉	10642.5	-1090.0	288	COM ₄₄	10298.5	1085.0
187	C ₂₊	6789.0	-1090.0	238	DMY ₁₀	10845.0	-881.5	289	COM ₄₃	10255.5	1085.0
188	C ₂₊	6862.0	-1090.0	239	DMY ₁₁	10845.0	-838.5	290	COM ₄₂	10212.5	1085.0
189	C ₂₊	6935.0	-1090.0	240	DMY ₁₂	10845.0	-795.5	291	COM ₄₁	10169.5	1085.0
190	C ₂₊	7008.0	-1090.0	241	DMY ₁₃	10845.0	-752.5	292	COM ₄₀	10126.5	1085.0
191	C ₂₊	7081.0	-1090.0	242	DMY ₁₄	10845.0	-709.5	293	COM ₃₉	10083.5	1085.0
192	C ₂₊	7154.0	-1090.0	243	DMY ₁₅	10845.0	-666.5	294	COM ₃₈	10040.5	1085.0
193	C ₂₋	7263.5	-1090.0	244	DMY ₁₆	10845.0	-623.5	295	COM ₃₇	9997.5	1085.0
194	C ₂₋	7336.5	-1090.0	245	DMY ₁₇	10845.0	-580.5	296	COM ₃₆	9954.5	1085.0
195	C ₂₋	7409.5	-1090.0	246	DMY ₁₈	10845.0	-537.5	297	COM ₃₅	9911.5	1085.0
196	C ₂₋	7482.5	-1090.0	247	DMY ₁₉	10845.0	-494.5	298	COM ₃₄	9868.5	1085.0
197	C ₂₋	7555.5	-1090.0	248	DMY ₂₀	10845.0	-451.5	299	COM ₃₃	9825.5	1085.0
198	C ₂₋	7628.5	-1090.0	249	DMY ₂₁	10845.0	-408.5	300	COM ₃₂	9782.5	1085.0
199	C ₃₊	7738.0	-1090.0	250	DMY ₂₂	10845.0	-365.5	301	COM ₃₁	9739.5	1085.0
200	C ₃₊	7811.0	-1090.0	251	DMY ₂₃	10845.0	-322.5	302	COM ₃₀	9696.5	1085.0
201	C ₃₊	7884.0	-1090.0	252	DMY ₂₄	10845.0	-279.5	303	COM ₂₉	9653.5	1085.0
202	C ₃₊	7957.0	-1090.0	253	DMY ₂₅	10845.0	-236.5	304	COM ₂₈	9610.5	1085.0
203	C ₃₊	8030.0	-1090.0	254	DMY ₂₆	10845.0	-193.5	305	COM ₂₇	9567.5	1085.0
204	C ₃₊	8103.0	-1090.0	255	DMY ₂₇	10845.0	-150.5	306	COM ₂₆	9524.5	1085.0

■ PAD COORDINATES 3

Chip Size 22070μm x 2550μm (Chip Center 0μm x 0μm)

PAD No.	Terminal	X(μm)	Y(μm)	PAD No.	Terminal	X(μm)	Y(μm)	PAD No.	Terminal	X(μm)	Y(μm)
307	COM ₂₅	9481.5	1085.0	358	SEGB ₇	7288.5	1085.0	409	SEGB ₂₄	5095.5	1085.0
308	COM ₂₄	9438.5	1085.0	359	SEGC ₇	7245.5	1085.0	410	SEGC ₂₄	5052.5	1085.0
309	COM ₂₃	9395.5	1085.0	360	SEGA ₈	7202.5	1085.0	411	SEGA ₂₅	5009.5	1085.0
310	COM ₂₂	9352.5	1085.0	361	SEGB ₈	7159.5	1085.0	412	SEGB ₂₅	4966.5	1085.0
311	COM ₂₁	9309.5	1085.0	362	SEGC ₈	7116.5	1085.0	413	SEGC ₂₅	4923.5	1085.0
312	COM ₂₀	9266.5	1085.0	363	SEGA ₉	7073.5	1085.0	414	SEGA ₂₆	4880.5	1085.0
313	COM ₁₉	9223.5	1085.0	364	SEGB ₉	7030.5	1085.0	415	SEGB ₂₆	4837.5	1085.0
314	COM ₁₈	9180.5	1085.0	365	SEGC ₉	6987.5	1085.0	416	SEGC ₂₆	4794.5	1085.0
315	COM ₁₇	9137.5	1085.0	366	SEGA ₁₀	6944.5	1085.0	417	SEGA ₂₇	4751.5	1085.0
316	COM ₁₆	9094.5	1085.0	367	SEGB ₁₀	6901.5	1085.0	418	SEGB ₂₇	4708.5	1085.0
317	COM ₁₅	9051.5	1085.0	368	SEGC ₁₀	6858.5	1085.0	419	SEGC ₂₇	4665.5	1085.0
318	COM ₁₄	9008.5	1085.0	369	SEGA ₁₁	6815.5	1085.0	420	SEGA ₂₈	4622.5	1085.0
319	COM ₁₃	8965.5	1085.0	370	SEGB ₁₁	6772.5	1085.0	421	SEGB ₂₈	4579.5	1085.0
320	COM ₁₂	8922.5	1085.0	371	SEGC ₁₁	6729.5	1085.0	422	SEGC ₂₈	4536.5	1085.0
321	COM ₁₁	8879.5	1085.0	372	SEGA ₁₂	6686.5	1085.0	423	SEGA ₂₉	4493.5	1085.0
322	COM ₁₀	8836.5	1085.0	373	SEGB ₁₂	6643.5	1085.0	424	SEGB ₂₉	4450.5	1085.0
323	COM ₉	8793.5	1085.0	374	SEGC ₁₂	6600.5	1085.0	425	SEGC ₂₉	4407.5	1085.0
324	COM ₈	8750.5	1085.0	375	SEGA ₁₃	6557.5	1085.0	426	SEGA ₃₀	4364.5	1085.0
325	COM ₇	8707.5	1085.0	376	SEGB ₁₃	6514.5	1085.0	427	SEGB ₃₀	4321.5	1085.0
326	COM ₆	8664.5	1085.0	377	SEGC ₁₃	6471.5	1085.0	428	SEGC ₃₀	4278.5	1085.0
327	COM ₅	8621.5	1085.0	378	SEGA ₁₄	6428.5	1085.0	429	SEGA ₃₁	4235.5	1085.0
328	COM ₄	8578.5	1085.0	379	SEGB ₁₄	6385.5	1085.0	430	SEGB ₃₁	4192.5	1085.0
329	COM ₃	8535.5	1085.0	380	SEGC ₁₄	6342.5	1085.0	431	SEGC ₃₁	4149.5	1085.0
330	COM ₂	8492.5	1085.0	381	SEGA ₁₅	6299.5	1085.0	432	SEGA ₃₂	4106.5	1085.0
331	COM ₁	8449.5	1085.0	382	SEGB ₁₅	6256.5	1085.0	433	SEGB ₃₂	4063.5	1085.0
332	COM ₀	8406.5	1085.0	383	SEGC ₁₅	6213.5	1085.0	434	SEGC ₃₂	4020.5	1085.0
333	SEGA ₀	8363.5	1085.0	384	SEGA ₁₆	6170.5	1085.0	435	SEGA ₃₃	3977.5	1085.0
334	SEGSB ₀	8320.5	1085.0	385	SEGB ₁₆	6127.5	1085.0	436	SEGB ₃₃	3934.5	1085.0
335	SEGSC ₀	8277.5	1085.0	386	SEGC ₁₆	6084.5	1085.0	437	SEGC ₃₃	3891.5	1085.0
336	SEGA ₀	8234.5	1085.0	387	SEGA ₁₇	6041.5	1085.0	438	SEGA ₃₄	3848.5	1085.0
337	SEGB ₀	8191.5	1085.0	388	SEGB ₁₇	5998.5	1085.0	439	SEGB ₃₄	3805.5	1085.0
338	SEGC ₀	8148.5	1085.0	389	SEGC ₁₇	5955.5	1085.0	440	SEGC ₃₄	3762.5	1085.0
339	SEGA ₁	8105.5	1085.0	390	SEGA ₁₈	5912.5	1085.0	441	SEGA ₃₅	3719.5	1085.0
340	SEGB ₁	8062.5	1085.0	391	SEGB ₁₈	5869.5	1085.0	442	SEGB ₃₅	3676.5	1085.0
341	SEGC ₁	8019.5	1085.0	392	SEGC ₁₈	5826.5	1085.0	443	SEGC ₃₅	3633.5	1085.0
342	SEGA ₂	7976.5	1085.0	393	SEGA ₁₉	5783.5	1085.0	444	SEGA ₃₆	3590.5	1085.0
343	SEGB ₂	7933.5	1085.0	394	SEGB ₁₉	5740.5	1085.0	445	SEGB ₃₆	3547.5	1085.0
344	SEGC ₂	7890.5	1085.0	395	SEGC ₁₉	5697.5	1085.0	446	SEGC ₃₆	3504.5	1085.0
345	SEGA ₂	7847.5	1085.0	396	SEGA ₂₀	5654.5	1085.0	447	SEGA ₃₇	3461.5	1085.0
346	SEGB ₃	7804.5	1085.0	397	SEGB ₂₀	5611.5	1085.0	448	SEGB ₃₇	3418.5	1085.0
347	SEGC ₃	7761.5	1085.0	398	SEGC ₂₀	5568.5	1085.0	449	SEGC ₃₇	3375.5	1085.0
348	SEGA ₄	7718.5	1085.0	399	SEGA ₂₁	5525.5	1085.0	450	SEGA ₃₈	3332.5	1085.0
349	SEGB ₄	7675.5	1085.0	400	SEGB ₂₁	5482.5	1085.0	451	SEGB ₃₈	3289.5	1085.0
350	SEGC ₄	7632.5	1085.0	401	SEGC ₂₁	5439.5	1085.0	452	SEGC ₃₈	3246.5	1085.0
351	SEGA ₅	7589.5	1085.0	402	SEGA ₂₂	5396.5	1085.0	453	SEGA ₃₉	3203.5	1085.0
352	SEGB ₅	7546.5	1085.0	403	SEGB ₂₂	5353.5	1085.0	454	SEGB ₃₉	3160.5	1085.0
353	SEGC ₅	7503.5	1085.0	404	SEGC ₂₂	5310.5	1085.0	455	SEGC ₃₉	3117.5	1085.0
354	SEGA ₆	7460.5	1085.0	405	SEGA ₂₃	5267.5	1085.0	456	SEGA ₄₀	3074.5	1085.0
355	SEGB ₆	7417.5	1085.0	406	SEGB ₂₃	5224.5	1085.0	457	SEGB ₄₀	3031.5	1085.0
356	SEGC ₆	7374.5	1085.0	407	SEGC ₂₃	5181.5	1085.0	458	SEGC ₄₀	2988.5	1085.0
357	SEGA ₇	7331.5	1085.0	408	SEGA ₂₄	5138.5	1085.0	459	SEGA ₄₁	2945.5	1085.0

■ PAD COORDINATES 4

Chip Size 22070μm x 2550μm (Chip Center 0μm x 0μm)

PAD No.	Terminal	X(μm)	Y(μm)	PAD No.	Terminal	X(μm)	Y(μm)	PAD No.	Terminal	X(μm)	Y(μm)
460	SEGB ₄₁	2902.5	1085.0	511	SEGB ₅₈	709.5	1085.0	562	SEGB ₇₅	-1483.5	1085.0
461	SEGC ₄₁	2859.5	1085.0	512	SEGC ₅₈	666.5	1085.0	563	SEGC ₇₅	-1526.5	1085.0
462	SEGA ₄₂	2816.5	1085.0	513	SEGA ₅₉	623.5	1085.0	564	SEGA ₇₆	-1569.5	1085.0
463	SEGB ₄₂	2773.5	1085.0	514	SEGB ₅₉	580.5	1085.0	565	SEGB ₇₆	-1612.5	1085.0
464	SEGC ₄₂	2730.5	1085.0	515	SEGC ₅₉	537.5	1085.0	566	SEGC ₇₆	-1655.5	1085.0
465	SEGA ₄₃	2687.5	1085.0	516	SEGA ₆₀	494.5	1085.0	567	SEGA ₇₇	-1698.5	1085.0
466	SEGB ₄₃	2644.5	1085.0	517	SEGB ₆₀	451.5	1085.0	568	SEGB ₇₇	-1741.5	1085.0
467	SEGC ₄₃	2601.5	1085.0	518	SEGC ₆₀	408.5	1085.0	569	SEGC ₇₇	-1784.5	1085.0
468	SEGA ₄₄	2558.5	1085.0	519	SEGA ₆₁	365.5	1085.0	570	SEGA ₇₈	-1827.5	1085.0
469	SEGB ₄₄	2515.5	1085.0	520	SEGB ₆₁	322.5	1085.0	571	SEGB ₇₈	-1870.5	1085.0
470	SEGC ₄₄	2472.5	1085.0	521	SEGC ₆₁	279.5	1085.0	572	SEGC ₇₈	-1913.5	1085.0
471	SEGA ₄₅	2429.5	1085.0	522	SEGA ₆₂	236.5	1085.0	573	SEGA ₇₉	-1956.5	1085.0
472	SEGB ₄₅	2386.5	1085.0	523	SEGB ₆₂	193.5	1085.0	574	SEGB ₇₉	-1999.5	1085.0
473	SEGC ₄₅	2343.5	1085.0	524	SEGC ₆₂	150.5	1085.0	575	SEGC ₇₉	-2042.5	1085.0
474	SEGA ₄₆	2300.5	1085.0	525	SEGA ₆₃	107.5	1085.0	576	SEGA ₈₀	-2085.5	1085.0
475	SEGB ₄₆	2257.5	1085.0	526	SEGB ₆₃	64.5	1085.0	577	SEGB ₈₀	-2128.5	1085.0
476	SEGC ₄₆	2214.5	1085.0	527	SEGC ₆₃	21.5	1085.0	578	SEGC ₈₀	-2171.5	1085.0
477	SEGA ₄₇	2171.5	1085.0	528	SEGA ₆₄	-21.5	1085.0	579	SEGA ₈₁	-2214.5	1085.0
478	SEGB ₄₇	2128.5	1085.0	529	SEGB ₆₄	-64.5	1085.0	580	SEGB ₈₁	-2257.5	1085.0
479	SEGC ₄₇	2085.5	1085.0	530	SEGC ₆₄	-107.5	1085.0	581	SEGC ₈₁	-2300.5	1085.0
480	SEGA ₄₈	2042.5	1085.0	531	SEGA ₆₅	-150.5	1085.0	582	SEGA ₈₂	-2343.5	1085.0
481	SEGB ₄₈	1999.5	1085.0	532	SEGB ₆₅	-193.5	1085.0	583	SEGB ₈₂	-2386.5	1085.0
482	SEGC ₄₈	1956.5	1085.0	533	SEGC ₆₅	-236.5	1085.0	584	SEGC ₈₂	-2429.5	1085.0
483	SEGA ₄₉	1913.5	1085.0	534	SEGA ₆₆	-279.5	1085.0	585	SEGA ₈₃	-2472.5	1085.0
484	SEGB ₄₉	1870.5	1085.0	535	SEGB ₆₆	-322.5	1085.0	586	SEGB ₈₃	-2515.5	1085.0
485	SEGC ₄₉	1827.5	1085.0	536	SEGC ₆₆	-365.5	1085.0	587	SEGC ₈₃	-2558.5	1085.0
486	SEGA ₅₀	1784.5	1085.0	537	SEGA ₆₇	-408.5	1085.0	588	SEGA ₈₄	-2601.5	1085.0
487	SEGB ₅₀	1741.5	1085.0	538	SEGB ₆₇	-451.5	1085.0	589	SEGB ₈₄	-2644.5	1085.0
488	SEGC ₅₀	1698.5	1085.0	539	SEGC ₆₇	-494.5	1085.0	590	SEGC ₈₄	-2687.5	1085.0
489	SEGA ₅₁	1655.5	1085.0	540	SEGA ₆₈	-537.5	1085.0	591	SEGA ₈₅	-2730.5	1085.0
490	SEGB ₅₁	1612.5	1085.0	541	SEGB ₆₈	-580.5	1085.0	592	SEGB ₈₅	-2773.5	1085.0
491	SEGC ₅₁	1569.5	1085.0	542	SEGC ₆₈	-623.5	1085.0	593	SEGC ₈₅	-2816.5	1085.0
492	SEGA ₅₂	1526.5	1085.0	543	SEGA ₆₉	-666.5	1085.0	594	SEGA ₈₆	-2859.5	1085.0
493	SEGB ₅₂	1483.5	1085.0	544	SEGB ₆₉	-709.5	1085.0	595	SEGB ₈₆	-2902.5	1085.0
494	SEGC ₅₂	1440.5	1085.0	545	SEGC ₆₉	-752.5	1085.0	596	SEGC ₈₆	-2945.5	1085.0
495	SEGA ₅₃	1397.5	1085.0	546	SEGA ₇₀	-795.5	1085.0	597	SEGA ₈₇	-2988.5	1085.0
496	SEGB ₅₃	1354.5	1085.0	547	SEGB ₇₀	-838.5	1085.0	598	SEGB ₈₇	-3031.5	1085.0
497	SEGC ₅₃	1311.5	1085.0	548	SEGC ₇₀	-881.5	1085.0	599	SEGC ₈₇	-3074.5	1085.0
498	SEGA ₅₄	1268.5	1085.0	549	SEGA ₇₁	-924.5	1085.0	600	SEGA ₈₈	-3117.5	1085.0
499	SEGB ₅₄	1225.5	1085.0	550	SEGB ₇₁	-967.5	1085.0	601	SEGB ₈₈	-3160.5	1085.0
500	SEGC ₅₄	1182.5	1085.0	551	SEGC ₇₁	-1010.5	1085.0	602	SEGC ₈₈	-3203.5	1085.0
501	SEGA ₅₅	1139.5	1085.0	552	SEGA ₇₂	-1053.5	1085.0	603	SEGA ₈₉	-3246.5	1085.0
502	SEGB ₅₅	1096.5	1085.0	553	SEGB ₇₂	-1096.5	1085.0	604	SEGB ₈₉	-3289.5	1085.0
503	SEGC ₅₅	1053.5	1085.0	554	SEGC ₇₂	-1139.5	1085.0	605	SEGC ₈₉	-3332.5	1085.0
504	SEGA ₅₆	1010.5	1085.0	555	SEGA ₇₃	-1182.5	1085.0	606	SEGA ₉₀	-3375.5	1085.0
505	SEGB ₅₆	967.5	1085.0	556	SEGB ₇₃	-1225.5	1085.0	607	SEGB ₉₀	-3418.5	1085.0
506	SEGC ₅₆	924.5	1085.0	557	SEGC ₇₃	-1268.5	1085.0	608	SEGC ₉₀	-3461.5	1085.0
507	SEGA ₅₇	881.5	1085.0	558	SEGA ₇₄	-1311.5	1085.0	609	SEGA ₉₁	-3504.5	1085.0
508	SEGB ₅₇	838.5	1085.0	559	SEGB ₇₄	-1354.5	1085.0	610	SEGB ₉₁	-3547.5	1085.0
509	SEGC ₅₇	795.5	1085.0	560	SEGC ₇₄	-1397.5	1085.0	611	SEGC ₉₁	-3590.5	1085.0
510	SEGA ₅₈	752.5	1085.0	561	SEGA ₇₅	-1440.5	1085.0	612	SEGA ₉₂	-3633.5	1085.0

■ PAD COORDINATES 5

Chip Size 22070μm x 2550μm (Chip Center 0μm x 0μm)

PAD No.	Terminal	X(μm)	Y(μm)	PAD No.	Terminal	X(μm)	Y(μm)	PAD No.	Terminal	X(μm)	Y(μm)
613	SEGB ₉₂	-3676.5	1085.0	664	SEGB ₁₀₉	-5869.5	1085.0	715	SEGB ₁₂₆	-8062.5	1085.0
614	SEGC ₉₂	-3719.5	1085.0	665	SEGC ₁₀₉	-5912.5	1085.0	716	SEGC ₁₂₆	-8105.5	1085.0
615	SEGA ₉₃	-3762.5	1085.0	666	SEGA ₁₁₀	-5955.5	1085.0	717	SEGA ₁₂₇	-8148.5	1085.0
616	SEGB ₉₃	-3805.5	1085.0	667	SEGB ₁₁₀	-5998.5	1085.0	718	SEGB ₁₂₇	-8191.5	1085.0
617	SEGC ₉₃	-3848.5	1085.0	668	SEGC ₁₁₀	-6041.5	1085.0	719	SEGC ₁₂₇	-8234.5	1085.0
618	SEGA ₉₄	-3891.5	1085.0	669	SEGA ₁₁₁	-6084.5	1085.0	720	SEGSA ₁	-8277.5	1085.0
619	SEGB ₉₄	-3934.5	1085.0	670	SEGB ₁₁₁	-6127.5	1085.0	721	SEGSB ₁	-8320.5	1085.0
620	SEGC ₉₄	-3977.5	1085.0	671	SEGC ₁₁₁	-6170.5	1085.0	722	SEGSC ₁	-8363.5	1085.0
621	SEGA ₉₅	-4020.5	1085.0	672	SEGA ₁₁₂	-6213.5	1085.0	723	COM ₆₄	-8406.5	1085.0
622	SEGB ₉₅	-4063.5	1085.0	673	SEGB ₁₁₂	-6256.5	1085.0	724	COM ₆₅	-8449.5	1085.0
623	SEGC ₉₅	-4106.5	1085.0	674	SEGC ₁₁₂	-6299.5	1085.0	725	COM ₆₆	-8492.5	1085.0
624	SEGA ₉₆	-4149.5	1085.0	675	SEGA ₁₁₃	-6342.5	1085.0	726	COM ₆₇	-8535.5	1085.0
625	SEGB ₉₆	-4192.5	1085.0	676	SEGB ₁₁₃	-6385.5	1085.0	727	COM ₆₈	-8578.5	1085.0
626	SEGC ₉₆	-4235.5	1085.0	677	SEGC ₁₁₃	-6428.5	1085.0	728	COM ₆₉	-8621.5	1085.0
627	SEGA ₉₇	-4278.5	1085.0	678	SEGA ₁₁₄	-6471.5	1085.0	729	COM ₇₀	-8664.5	1085.0
628	SEGB ₉₇	-4321.5	1085.0	679	SEGB ₁₁₄	-6514.5	1085.0	730	COM ₇₁	-8707.5	1085.0
629	SEGC ₉₇	-4364.5	1085.0	680	SEGC ₁₁₄	-6557.5	1085.0	731	COM ₇₂	-8750.5	1085.0
630	SEGA ₉₈	-4407.5	1085.0	681	SEGA ₁₁₅	-6600.5	1085.0	732	COM ₇₃	-8793.5	1085.0
631	SEGB ₉₈	-4450.5	1085.0	682	SEGB ₁₁₅	-6643.5	1085.0	733	COM ₇₄	-8836.5	1085.0
632	SEGC ₉₈	-4493.5	1085.0	683	SEGC ₁₁₅	-6686.5	1085.0	734	COM ₇₅	-8879.5	1085.0
633	SEGA ₉₉	-4536.5	1085.0	684	SEGA ₁₁₆	-6729.5	1085.0	735	COM ₇₆	-8922.5	1085.0
634	SEGB ₉₉	-4579.5	1085.0	685	SEGB ₁₁₆	-6772.5	1085.0	736	COM ₇₇	-8965.5	1085.0
635	SEGC ₉₉	-4622.5	1085.0	686	SEGC ₁₁₆	-6815.5	1085.0	737	COM ₇₈	-9008.5	1085.0
636	SEGA ₁₀₀	-4665.5	1085.0	687	SEGA ₁₁₇	-6858.5	1085.0	738	COM ₇₉	-9051.5	1085.0
637	SEGB ₁₀₀	-4708.5	1085.0	688	SEGB ₁₁₇	-6901.5	1085.0	739	COM ₈₀	-9094.5	1085.0
638	SEGC ₁₀₀	-4751.5	1085.0	689	SEGC ₁₁₇	-6944.5	1085.0	740	COM ₈₁	-9137.5	1085.0
639	SEGA ₁₀₁	-4794.5	1085.0	690	SEGA ₁₁₈	-6987.5	1085.0	741	COM ₈₂	-9180.5	1085.0
640	SEGB ₁₀₁	-4837.5	1085.0	691	SEGB ₁₁₈	-7030.5	1085.0	742	COM ₈₃	-9223.5	1085.0
641	SEGC ₁₀₁	-4880.5	1085.0	692	SEGC ₁₁₈	-7073.5	1085.0	743	COM ₈₄	-9266.5	1085.0
642	SEGA ₁₀₂	-4923.5	1085.0	693	SEGA ₁₁₉	-7116.5	1085.0	744	COM ₈₅	-9309.5	1085.0
643	SEGB ₁₀₂	-4966.5	1085.0	694	SEGB ₁₁₉	-7159.5	1085.0	745	COM ₈₆	-9352.5	1085.0
644	SEGC ₁₀₂	-5009.5	1085.0	695	SEGC ₁₁₉	-7202.5	1085.0	746	COM ₈₇	-9395.5	1085.0
645	SEGA ₁₀₃	-5052.5	1085.0	696	SEGA ₁₂₀	-7245.5	1085.0	747	COM ₈₈	-9438.5	1085.0
646	SEGB ₁₀₃	-5095.5	1085.0	697	SEGB ₁₂₀	-7288.5	1085.0	748	COM ₈₉	-9481.5	1085.0
647	SEGC ₁₀₃	-5138.5	1085.0	698	SEGC ₁₂₀	-7331.5	1085.0	749	COM ₉₀	-9524.5	1085.0
648	SEGA ₁₀₄	-5181.5	1085.0	699	SEGA ₁₂₁	-7374.5	1085.0	750	COM ₉₁	-9567.5	1085.0
649	SEGB ₁₀₄	-5224.5	1085.0	700	SEGB ₁₂₁	-7417.5	1085.0	751	COM ₉₂	-9610.5	1085.0
650	SEGC ₁₀₄	-5267.5	1085.0	701	SEGC ₁₂₁	-7460.5	1085.0	752	COM ₉₃	-9653.5	1085.0
651	SEGA ₁₀₅	-5310.5	1085.0	702	SEGA ₁₂₂	-7503.5	1085.0	753	COM ₉₄	-9696.5	1085.0
652	SEGB ₁₀₅	-5353.5	1085.0	703	SEGB ₁₂₂	-7546.5	1085.0	754	COM ₉₅	-9739.5	1085.0
653	SEGC ₁₀₅	-5396.5	1085.0	704	SEGC ₁₂₂	-7589.5	1085.0	755	COM ₉₆	-9782.5	1085.0
654	SEGA ₁₀₆	-5439.5	1085.0	705	SEGA ₁₂₃	-7632.5	1085.0	756	COM ₉₇	-9825.5	1085.0
655	SEGB ₁₀₆	-5482.5	1085.0	706	SEGB ₁₂₃	-7675.5	1085.0	757	COM ₉₈	-9868.5	1085.0
656	SEGC ₁₀₆	-5525.5	1085.0	707	SEGC ₁₂₃	-7718.5	1085.0	758	COM ₉₉	-9911.5	1085.0
657	SEGA ₁₀₇	-5568.5	1085.0	708	SEGA ₁₂₄	-7761.5	1085.0	759	COM ₁₀₀	-9954.5	1085.0
658	SEGB ₁₀₇	-5611.5	1085.0	709	SEGB ₁₂₄	-7804.5	1085.0	760	COM ₁₀₁	-9997.5	1085.0
659	SEGC ₁₀₇	-5654.5	1085.0	710	SEGC ₁₂₄	-7847.5	1085.0	761	COM ₁₀₂	-10040.5	1085.0
660	SEGA ₁₀₈	-5697.5	1085.0	711	SEGA ₁₂₅	-7890.5	1085.0	762	COM ₁₀₃	-10083.5	1085.0
661	SEGB ₁₀₈	-5740.5	1085.0	712	SEGB ₁₂₅	-7933.5	1085.0	763	COM ₁₀₄	-10126.5	1085.0
662	SEGC ₁₀₈	-5783.5	1085.0	713	SEGC ₁₂₅	-7976.5	1085.0	764	COM ₁₀₅	-10169.5	1085.0
663	SEGA ₁₀₉	-5826.5	1085.0	714	SEGA ₁₂₆	-8019.5	1085.0	765	COM ₁₀₆	-10212.5	1085.0

■ PAD COORDINATES 6

Chip Size 22070μm x 2550μm (Chip Center 0μm x 0μm)

PAD No.	Terminal	X(μm)	Y(μm)	PAD No.	Terminal	X(μm)	Y(μm)	PAD No.	Terminal	X(μm)	Y(μm)
766	COM ₁₀₇	-10255.5	1085.0	817	DMY ₇₁	-10845.0	-881.5				
767	COM ₁₀₈	-10298.5	1085.0								
768	COM ₁₀₉	-10341.5	1085.0								
769	COM ₁₁₀	-10384.5	1085.0								
770	COM ₁₁₁	-10427.5	1085.0								
771	COM ₁₁₂	-10470.5	1085.0								
772	COM ₁₁₃	-10513.5	1085.0								
773	DMY ₄₁	-10556.5	1085.0								
774	DMY ₄₂	-10599.5	1085.0								
775	DMY ₄₃	-10642.5	1085.0								
776	DMY ₄₄	-10845.0	881.5								
777	DMY ₄₅	-10845.0	838.5								
778	DMY ₄₆	-10845.0	795.5								
779	COM ₁₁₄	-10845.0	752.5								
780	COM ₁₁₅	-10845.0	709.5								
781	COM ₁₁₆	-10845.0	666.5								
782	COM ₁₁₇	-10845.0	623.5								
783	COM ₁₁₈	-10845.0	580.5								
784	COM ₁₁₉	-10845.0	537.5								
785	COM ₁₂₀	-10845.0	494.5								
786	COM ₁₂₁	-10845.0	451.5								
787	COM ₁₂₂	-10845.0	408.5								
788	COM ₁₂₃	-10845.0	365.5								
789	COM ₁₂₄	-10845.0	322.5								
790	COM ₁₂₅	-10845.0	279.5								
791	COM ₁₂₆	-10845.0	236.5								
792	COM ₁₂₇	-10845.0	193.5								
793	DMY ₄₇	-10845.0	150.5								
794	DMY ₄₈	-10845.0	107.5								
795	DMY ₄₉	-10845.0	64.5								
796	DMY ₅₀	-10845.0	21.5								
797	DMY ₅₁	-10845.0	-21.5								
798	DMY ₅₂	-10845.0	-64.5								
799	DMY ₅₃	-10845.0	-107.5								
800	DMY ₅₄	-10845.0	-150.5								
801	DMY ₅₅	-10845.0	-193.5								
802	DMY ₅₆	-10845.0	-236.5								
803	DMY ₅₇	-10845.0	-279.5								
804	DMY ₅₈	-10845.0	-322.5								
805	DMY ₅₉	-10845.0	-365.5								
806	DMY ₆₀	-10845.0	-408.5								
807	DMY ₆₁	-10845.0	-451.5								
808	DMY ₆₂	-10845.0	-494.5								
809	DMY ₆₃	-10845.0	-537.5								
810	DMY ₆₄	-10845.0	-580.5								
811	DMY ₆₅	-10845.0	-623.5								
812	DMY ₆₆	-10845.0	-666.5								
813	DMY ₆₇	-10845.0	-709.5								
814	DMY ₆₈	-10845.0	-752.5								
815	DMY ₆₉	-10845.0	-795.5								
816	DMY ₇₀	-10845.0	-838.5								

■ BLOCK DIAGRAM

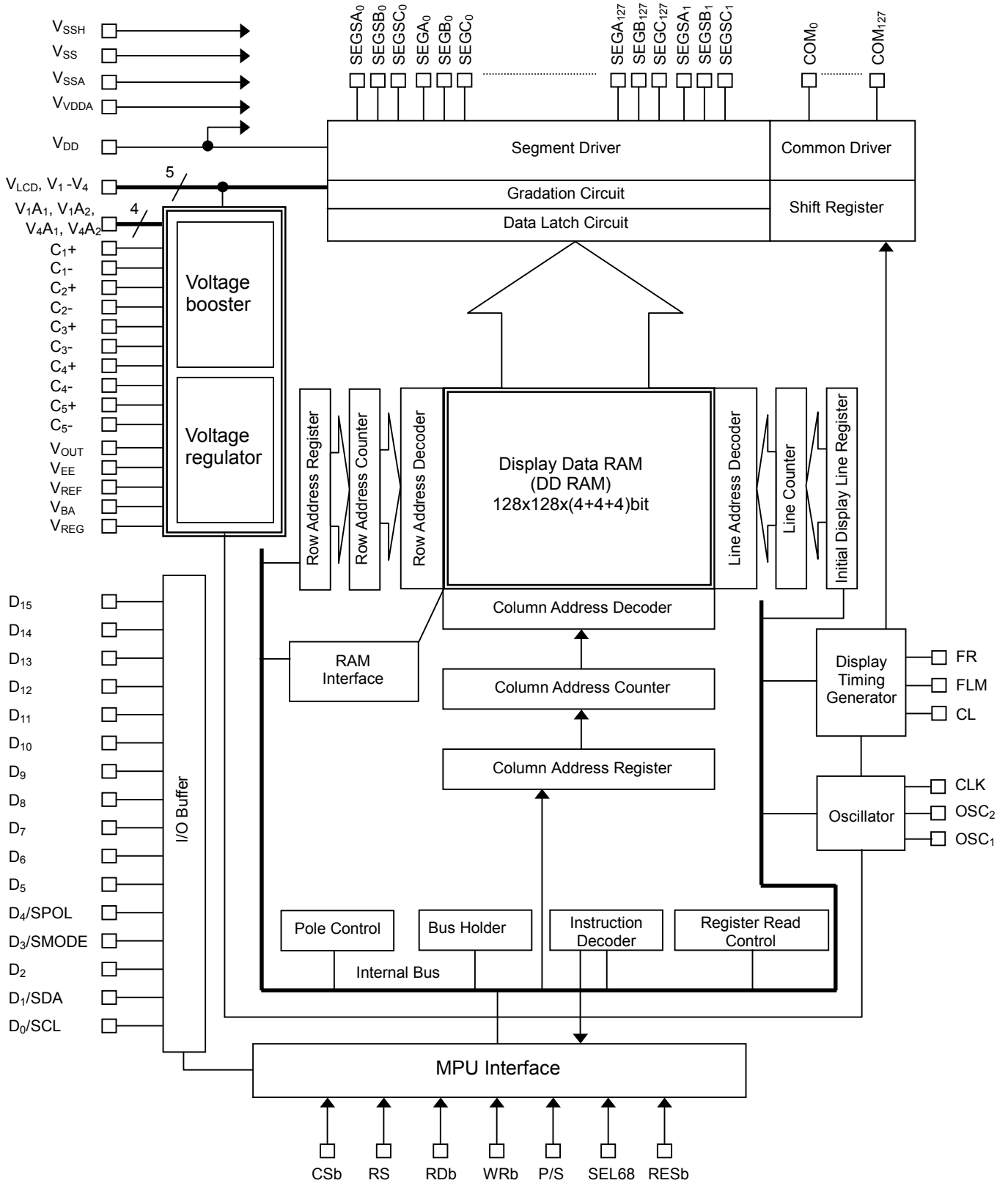

POWER SUPPLY CIRCUITS BLOCK DIAGRAM

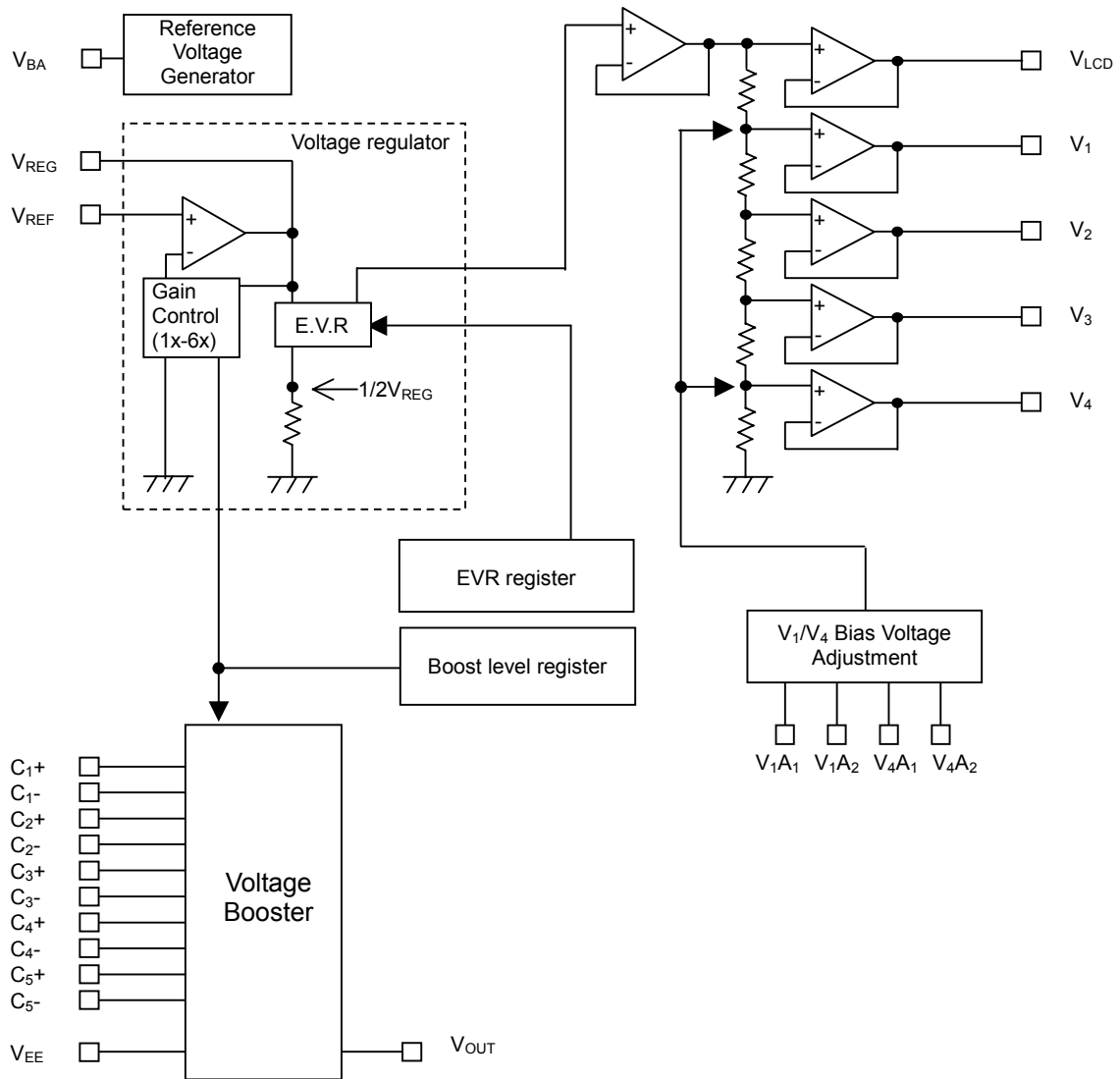

■ TERMINAL DESCRIPTION 1

No.	Symbol	I/O	Function						
64~70	V_{DD}	Power	Power supply for logic circuits						
83~89	V_{SS}	Power	GND for logic circuits						
154~160	V_{SSH}	Power	GND for high voltage circuits						
8,9, 28,29, 92,93, 100,101	V_{DDA}	Power	This terminal is internally connected to the V_{DD} level. •This terminal is used to fix the selection terminals to the V_{DD} level. Note) Do not use this terminal for a main power supply.						
4,5, 12,13, 46,47, 96,97, 104,105	V_{SSA}	Power	This terminal is internally connected to the V_{SS} level. •This terminal is used to fix the selection terminals to the V_{SS} level. Note) Do not use this terminal for a main GND.						
106~111 112~117 118~123 124~129 130~135	V_{LCD} V_1 V_2 V_3 V_4	Power/O	LCD driving voltages •When the internal voltage booster is not used, external LCD driving voltages (V_1 to V_4 and V_{LCD}) must be supplied on these terminals. The external voltages must be maintained with the following relation. $V_{SS} < V_4 < V_3 < V_2 < V_1 < V_{LCD}$ • When the internal voltage booster is used, the LCD driving voltages (V_1 to V_4 and V_{LCD}) are enabled by the "Power control" instruction. The capacitors between the V_{SS} and these terminals are necessary.						
175~180 181~186	C_{1+} C_{1-}	O	Capacitor connection terminals for the voltage booster						
187~192 193~198	C_{2+} C_{2-}	O	Capacitor connection terminals for the voltage booster						
199~204 205~210	C_{3+} C_{3-}	O	Capacitor connection terminals for the voltage booster						
211~216 217~222	C_{4+} C_{4-}	O	Capacitor connection terminals for the voltage booster						
223~228 229~234	C_{5+} C_{5-}	O	Capacitor connection terminals for the voltage booster						
148~153	V_{BA}	O	Output of the reference-voltage generator						
142~147	V_{REF}	I	Input of the voltage regulator						
168~174	V_{EE}	Power	Input of the voltage booster •This terminal is normally connected to the V_{DD} level.						
161~167	V_{OUT}	Power/O	Output of the voltage booster Input for high voltage circuits in using external power supply						
136~141	V_{REG}	O	Output of the voltage regulator						
90,91 94,95	V_1A_1 V_1A_2	I	V_1 bias voltage adjustment terminal						
98,99 102,103	V_4A_1 V_4A_2	I	V_4 bias voltage adjustment terminal						
14,15	RESb	I	Reset Active "0"						
6,7	SEL68	I	MPU interface type select <table border="1" style="margin-left: auto; margin-right: auto;"> <tr> <td>SEL86</td> <td>H</td> <td>L</td> </tr> <tr> <td>Status</td> <td>68 series</td> <td>80 series</td> </tr> </table>	SEL86	H	L	Status	68 series	80 series
SEL86	H	L							
Status	68 series	80 series							

■ TERMINAL DESCRIPTION 2

No.	Symbol	I/O	Function						
30,31	D ₀ /SCL	I/O	<p><u>Parallel interface:</u> D₇ to D₀ : 8-bit bi-directional bus</p> <ul style="list-style-type: none"> In the parallel interface mode (P/S="1"), these terminals connect to 8-bit bi-directional MPU bus. <p><u>Serial interface:</u> SDA : serial data SCL : serial clock SMODE : 3-/4-line serial interface mode selection SPOL : RS polarity selection (in the 3-line serial interface mode)</p> <ul style="list-style-type: none"> In the 3-/4-line serial interface mode (P/S="0"), the D₀ terminal is assigned to the SCL and the D₁ terminal to the SDA. In the 3-line serial interface mode, the D₄ terminal is assigned to the SPOL. Serial data on the SDA is fetched at the rising edge of the SCL signal in the order of the D₇, D₆...D₀, and the fetched data is converted into 8-bit parallel data at the falling edge of the 8th SCL signal. The SCL signal must be set to "0" after data transmissions or during non-access. 						
32,33	D ₁ /SDA	I/O							
36,37	D ₃ /SMODE	I/O							
38,39	D ₄ /SPOL	I/O							
34,35 40,41 42,43 44,45	D ₂ D ₅ D ₆ D ₇	I/O							
48,49 50,51 52,53 54,55 56,57 58,59 60,61 62,63	D ₈ D ₉ D ₁₀ D ₁₁ D ₁₂ D ₁₃ D ₁₄ D ₁₅	I/O	<p>8-bit bi-directional bus</p> <ul style="list-style-type: none"> In the 16-bit data bus mode, these terminals are assigned to the upper 8-bit data bus. In the serial interface mode or 8-bit data bus mode of the parallel interface, these terminals must be fixed to "1" or "0". 						
17,18	CSb	I	Chip select Active "0"						
20,21	RS	I	<p>Resister select</p> <ul style="list-style-type: none"> This signal distinguishes transferred data as an instruction or display data as follows. <table border="1" style="margin-left: auto; margin-right: auto;"> <tr> <td>RS</td> <td>H</td> <td>L</td> </tr> <tr> <td>Distinct.</td> <td>Instruction</td> <td>Display data</td> </tr> </table>	RS	H	L	Distinct.	Instruction	Display data
RS	H	L							
Distinct.	Instruction	Display data							
26,27	RD _b (E)	I	<p>80 series MPU interface (P/S="1", SEL68="0") RD_b signal. Active "0".</p> <p>68 series MPU interface (P/S="1", SEL68="1") Enable signal. Active "1".</p>						
23,24	WR _b (R/W)	I	<p>80 series MPU interface (P/S="1", SEL68="0") WR_b signal. Active "0".</p> <p>68 series MPU interface (P/S="1", SEL68="1") R/W signal.</p> <table border="1" style="margin-left: auto; margin-right: auto;"> <tr> <td>R/W</td> <td>H</td> <td>L</td> </tr> <tr> <td>Status</td> <td>Read</td> <td>Write</td> </tr> </table>	R/W	H	L	Status	Read	Write
R/W	H	L							
Status	Read	Write							

■ TERMINAL DESCRIPTION 3

No.	Symbol	I/O	Function																		
10,11	P/S	I	Parallel / serial interface mode selection <table border="1" style="margin-left: 20px;"> <thead> <tr> <th>P/S</th> <th>Chip Select</th> <th>Data/ Instruction</th> <th>Data</th> <th>Read/Write</th> <th>Serial clock</th> </tr> </thead> <tbody> <tr> <td>H</td> <td>CSb</td> <td>RS</td> <td>D₀ ~ D₇</td> <td>RDb, WRb</td> <td>-</td> </tr> <tr> <td>L</td> <td>CSb</td> <td>RS</td> <td>SDA (D₁)</td> <td>Write only</td> <td>SCL (D₀)</td> </tr> </tbody> </table> <ul style="list-style-type: none"> • Since the D₁₅ to D₅ and D₂ terminals are in the high impedance in the serial interface mode (P/S="0"), they must be fixed to "1" or "0". The RDb and WRb terminals also must be "1" or "0". 	P/S	Chip Select	Data/ Instruction	Data	Read/Write	Serial clock	H	CSb	RS	D ₀ ~ D ₇	RDb, WRb	-	L	CSb	RS	SDA (D ₁)	Write only	SCL (D ₀)
P/S	Chip Select	Data/ Instruction	Data	Read/Write	Serial clock																
H	CSb	RS	D ₀ ~ D ₇	RDb, WRb	-																
L	CSb	RS	SDA (D ₁)	Write only	SCL (D ₀)																
71,72	CL	O	This terminal must be opened.																		
73,74	FLM	O	This terminal must be opened.																		
75,76	FR	O	This terminal must be opened.																		
77,78	CLK	O	This terminal must be opened.																		
79,80 81,82	OSC ₁ OSC ₂	I O	OSC <ul style="list-style-type: none"> • When the internal oscillator clock is used, OSC₁ terminal must be fixed to "1" or "0", and the OSC₂ terminal must be opened. When the oscillation frequency from the internal oscillator is adjusted by an external resistor between OSC₁ terminal and OSC₂. • When an external oscillator is used, external clock is input to the OSC₁ terminal or an external resistor is connected between the OSC₁ and OSC₂ terminals. 																		

■ TERMINAL DESCRIPTION 4

No.	Symbol	I/O	Function															
336~719	SEGA ₀ ~ SEGA ₁₂₇ , SEGB ₀ ~ SEGB ₁₂₇ , SEGC ₀ ~ SEGC ₁₂₇	O	Segment output <table border="1" style="margin: 10px auto;"> <thead> <tr> <th>REV Mode</th> <th>Turn-off</th> <th>Turn-on</th> </tr> </thead> <tbody> <tr> <td>Normal</td> <td>0</td> <td>1</td> </tr> <tr> <td>Reverse</td> <td>1</td> <td>0</td> </tr> </tbody> </table> <ul style="list-style-type: none"> •These terminals output LCD driving waveforms in accordance with the combination of the FR signal and display data. <p><u>In the B/W mode</u></p>	REV Mode	Turn-off	Turn-on	Normal	0	1	Reverse	1	0						
REV Mode	Turn-off	Turn-on																
Normal	0	1																
Reverse	1	0																
333,720 334,721 335,722	SEGSA ₀ , SEGSA ₁ SEGSB ₀ , SEGSB ₁ SEGSC ₀ , SEGSC ₁	O	Icon segment output terminal <ul style="list-style-type: none"> •These terminals are assigned at both edge of normal segment output terminals line for out line frame display. 															
332~283, 276~263, 723~772, 779~792	COM ₀ ~ COM ₁₂₇	O	Common output <ul style="list-style-type: none"> •These terminals output LCD driving waveforms in accordance with the combination of the FR signal and scanning data. <table border="1" style="margin: 10px auto;"> <thead> <tr> <th>Data</th> <th>FR</th> <th>Output level</th> </tr> </thead> <tbody> <tr> <td>H</td> <td>H</td> <td>V_{SS}</td> </tr> <tr> <td>L</td> <td>H</td> <td>V₁</td> </tr> <tr> <td>H</td> <td>L</td> <td>V_{LCD}</td> </tr> <tr> <td>L</td> <td>L</td> <td>V₄</td> </tr> </tbody> </table>	Data	FR	Output level	H	H	V _{SS}	L	H	V ₁	H	L	V _{LCD}	L	L	V ₄
Data	FR	Output level																
H	H	V _{SS}																
L	H	V ₁																
H	L	V _{LCD}																
L	L	V ₄																

(Terminal No. 1~3,16,19,22,25,235~262,277~282,773~778,793~817 are dummy.)

■ Functional Description

(1) MPU Interface

(1-1) Selection of parallel / serial interface mode

The P/S terminal is used to select parallel or serial interface mode as shown in the following table. In the serial interface mode, it is not possible to read out display data from the DDRAM and status from the internal registers.

Table1

P/S	P/S mode	CSb	RS	RDb	WRb	SEL68	SDA	SCL	Data
H	Parallel I/F	CSb	RS	RDb	WRb	SEL68	/	/	D ₇ -D ₀ (D ₁₅ -D ₀)
L	Serial I/F	CSb	RS	-	-	-	SDA	SCL	-

Note 1) “-” : Fix to “1” or “0”.

(1-2) Selection of MPU interface type

In the parallel interface mode, the SEL68 terminal is used to select 68- or 80-series MPU interface type as shown in the following table.

Table2

SEL68	MPU type	CSb	RS	RDb	WRb	Data
H	68 series MPU	CSb	RS	E	R/W	D ₇ -D ₀ (D ₁₅ -D ₀)
L	80 series MPU	CSb	RS	RDb	WRb	D ₇ -D ₀ (D ₁₅ -D ₀)

(1-3) Data distinction

In the parallel interface mode, the combination of RS, RDb, and WRb (R/W) signals distinguishes transferred data between the LSI and MPU as instruction or display data, as shown in the following table.

Table3

RS	68 series	80 series		Function
	R/W	RDb	WRb	
H	H	L	H	Read out instruction data
H	L	H	L	Write instruction data
L	H	L	H	Read out display data
L	L	H	L	Write display data

(1-4) Selection of serial interface mode

In the serial interface mode, the SMODE terminal is used to select the 3- or 4-line serial interface mode as shown in the following table.

Table4

SMODE	Serial interface mode
H	3-line
L	4-line

(1-5) 4-line serial interface mode

In the 4-line serial interface mode, when the chip select is active (CSb="0"), the SDA and the SCL are enabled. When the chip select is not active (CSb="1"), the SDA and the SCL are disabled and the internal shift register and the counter are being initialized. The 8-bit serial data on the SDA is fetched at the rising edge of the SCL signal (serial clock) in order of the D₇, D₆...D₀, and the fetched data is converted into the 8-bit parallel data at the rising edge of the 8th SCL signal.

In the 4-line serial interface mode, the transferred data on the SDA is distinguished as display data or instruction data in accordance with the condition of the RS signal.

Table5

RS	Data distinction
H	Instruction data
L	Display data

Since the serial interface operation is sensitive to external noises, the SCL should be set to "0" after data transmissions or during non-access. To release a mal-function caused by the external noises, the chip-selected status should be released (CSb="1") after each of the 8-bit data transmissions. The following figure illustrates the interface timing for the 4-line serial interface operation.

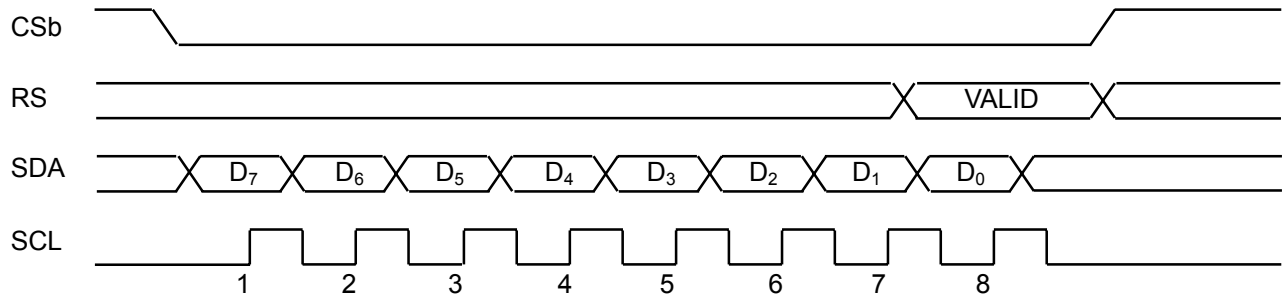

Fig1 4-line serial interface timing

(1-6) 3-line serial interface mode

In the 3-line serial interface mode, when the chip select is active (CSb="0"), the SDA and SCL are enabled. When the chip select is not active (CSb="1"), the SDA and SCL are disabled and the internal shift register and counter are being initialized. 9-bit serial data on the SDA is fetched at the rising edge of the SCL signal in order of the RS, D₇, D₆...D₀, and the fetched data is converted into the 9-bit parallel data at the rising edge of the 9th SCL signal.

In the 3-line serial interface mode, data on the SDA is distinguished as display data or instruction data in accordance with the condition of the RS bit of the SDA data and the status of the SPOL, as follows.

Table6

SPOL=L		SPOL=H	
RS	Data distinction	RS	Data distinction
L	Display data	L	Instruction data
H	Instruction data	H	Display data

Since the serial interface operation is sensitive to external noises, the SCL must be set to "0" after data transmissions or during non-access. To release a mal-function caused by the external noises, the chip-selected status should be released (CSb="1") after each of 9-bit data transmissions. The following figure illustrates the interface timing of the 3-line serial interface operation.

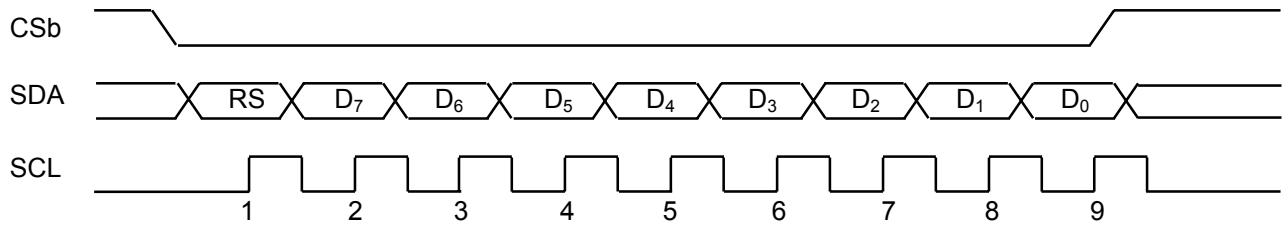

Fig2 3-line serial interface timing

(2) Access to the DDRAM

When the CSb signal is "0", the transferred data from MPU is written into the DDRAM or instruction register in accordance with the condition of the RS signal.

When the RS signal is "1", the transferred data is distinguished as display data. After the "column address" and "row address" instructions are executed, the display data can be written into the DDRAM by the "display data write" instruction. The display data is written at the rising edge of the WRb signal in the 80 series MPU mode, or at the falling edge of the E signal in the 68 series MPU mode.

Table6

RS	Data
L	Display RAM Data
H	Internal Command Register

In the sequence of the "display data read" operation, the transferred data from MPU is temporarily held in the internal bus-holder, then transferred to the internal data-bus. When the "display data read" operation is executed just after the "column address" and "row address" instructions or "display data write" instruction, unexpected data on the bus-holder is read out at the 1st execution, then the data of designated DDRAM address is read out from the 2nd execution. For this reason, a dummy read cycle must be executed to avoid the unexpected 1st data read.

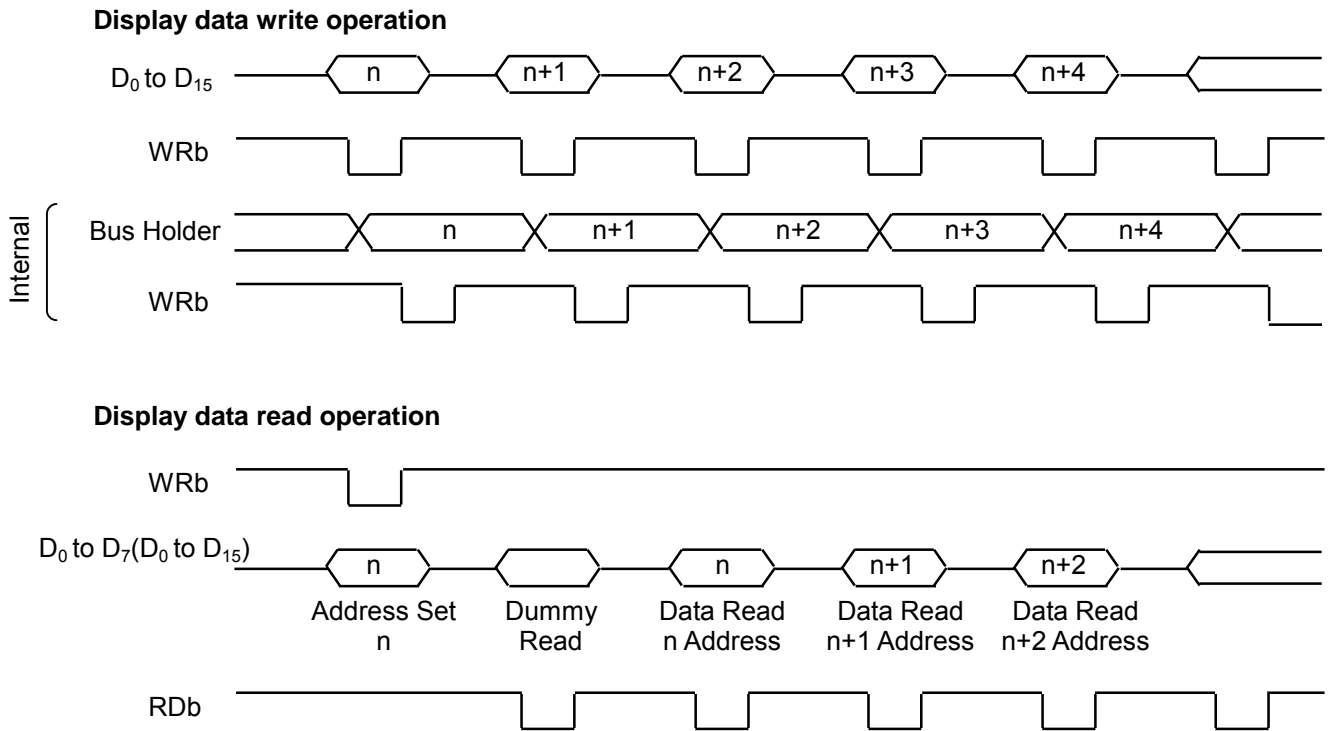

Fig3

Note) In the 16-bit data bus mode, instruction data must be 16-bit as well as the display data.

(3) Access to the instruction register

Each instruction registers is assigned to each address between 0_H and F_H , and the content of the instruction register can be read out by the combination of the "Instruction register address" and "Instruction register read".

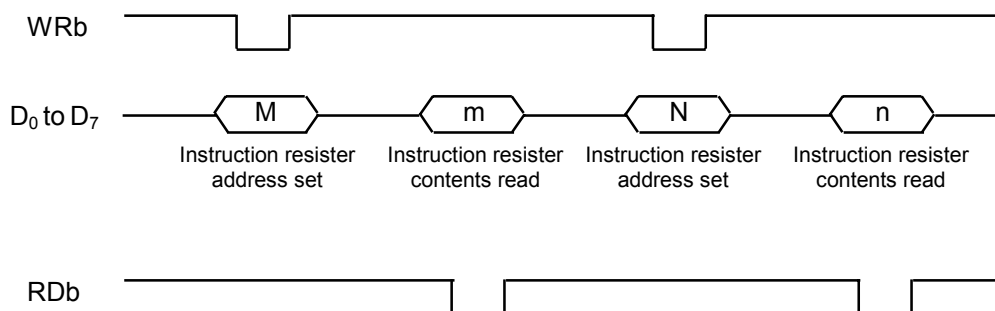

Fig4

(4) 8-/16-bit data bus length for display data (in the parallel interface mode)

The 8- or 16-bit data bus length for display data is determined by the "WLS" of the "Data bus length" instruction.

In the 16-bit data bus mode, instruction data must be 16-bit data (D_{15} to D_0) as well as display data. However, for the access to the instruction register, the only lower 8-bit data (D_7 to D_0) of the 16-bit data is valid. For the access to the DDRAM, all of the 16-bit data (D_{15} to D_0) is valid.

Table8

WLS	Data bus length mode
L	8-bit
H	16-bit

(5) Initial display line register

The initial display line register specifies the line address, corresponding to the initial COM line, by the "Initial display line" instruction. The initial COM line signifies the common driver, starting scanning the display data in the DDRAM, and specified by the "Initial COM line" instruction.

The line address, established in the initial display line register, is preset into the line counter whenever the FLM signal becomes "1". At the rising edge of the CL signal, the line counter is counted-up and addressed 384-bit display data corresponding to the counted-up line address, is latched into the data latch circuit. At the falling edge of the CL signal, the latched data outputs to the segment drivers.

(6) DDRAM mapping

The DDRAM is capable of 1,536-bit (12-bit x 128-segment) for the column address and 128-bit for the row address.

In the gradation mode, each pixel for RGB corresponds to successive 3-segment drivers, and each segment driver has 16-gradation. Therefore, the LSI can drive up to 128x128 pixels in 4096-color display (16-gradation x 16-gradation x 16-gradation).

In 8-bit access mode(C256 mode) for DDRAM, sequential twice accesses to DDRAM complete one pixel data access. Therefore, it must be accessed with a couple of operation.

- In the 8-bit data bus length mode

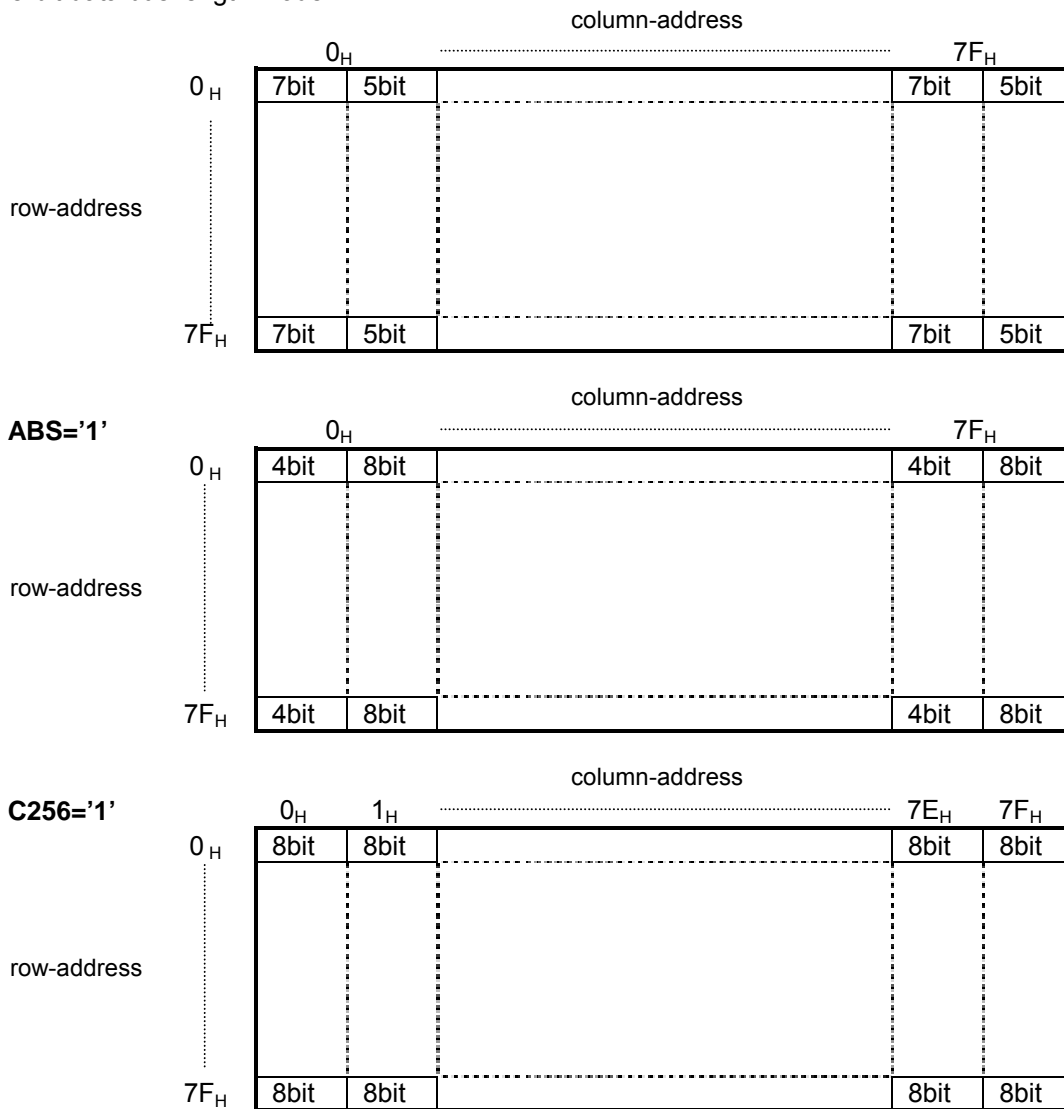

Fig5

- In the 16-bit data bus length mode

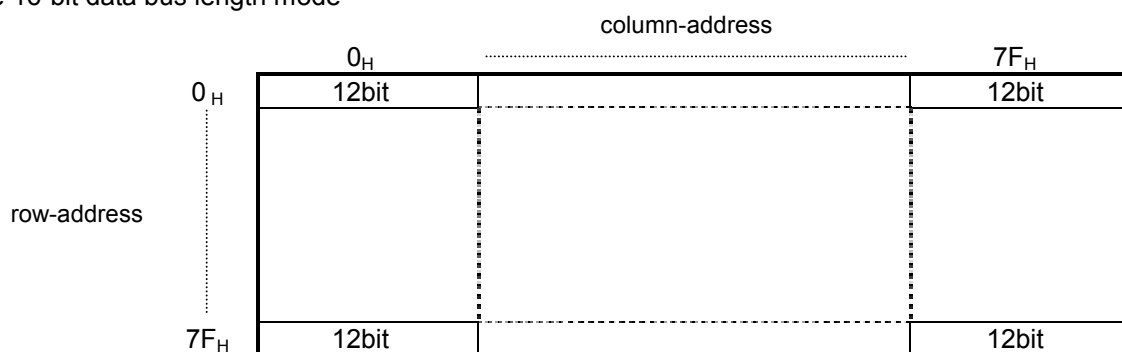

Fig6

In the B&W mode, only MSB data from each 4-bit display data group in the DDRAM is used. Therefore, 384 x 128 pixels in the B&W and 128 x 128 pixels in the 8-gradation are available.

The range of the column address varies depending on data bus length. The range between 00_H and 7F_H is used in the 8-bit or 16-bit data bus length.

The DDRAM is accessing 8-bit or 16-bit unit addressed by column and row address. In the 8-bit or 16-bit data bus length mode, over 80_H address setting is prohibited.

The increments for the column address and row address are set to the auto-increment mode by programming the "HV", "XD" and "YD" registers of the "Increment control" instruction. In this mode, the contents of the column address and row address counters automatically increment whenever the DDRAM is accessed.

The column address and row address counters, independent of the line counter. They are used to designate the column and row addresses for the display data transferred from MPU. On the other hand, the line counter is used to generate the line address, and output display data to the segment drivers, being synchronized with the display control timing of the FLM and CL signals.

Icon Segment Map 1

Mode	WLS	ABS	256	SEGS0												SEGS1													
				Palette A				Palette B				Palette C				Palette A				Palette B				Palette C					
16bit	1	0	0	D15 D14 D13 D12 D10 D9 D8 D7 D4 D3 D2 D1	X=00H												D15 D14 D13 D12 D10 D9 D8 D7 D4 D3 D2 D1	X=01H											
	1	1	0	D11 D10 D9 D8 D7 D6 D5 D4 D3 D2 D1 D0	X=00H												D11 D10 D9 D8 D7 D6 D5 D4 D3 D2 D1 D0	X=01H											
8bit	0	0	0	X=00H (Upper)												X=00H (Lower)													
	0	1	0	D7 D6 D5 D4 D2 D1 D0	X=00H (Upper)												D3 D2 D1 D0	X=01H (Lower)											

Icon Segment Map 2 (256 Color Mode)

Mode	WLS	ABS	256	SEGS0												SEGS1												
				Palette A				Palette B				Palette C				Palette A				Palette B				Palette C				
8bit	0	X	1	X=00H												X=01H												
				A3 A2 A1 A0 B3 B2 B1 B0 C3 C2 C1 C0	X=00H												A3 A2 A1 A0 B3 B2 B1 B0 C3 C2 C1 C0	X=01H										

SWMAP

SWAP	Palette A				Palette B				Palette C			
0	A3	A2	A1	A0	B3	B2	B1	B0	C3	C2	C1	C0
1	SEGSAX	SEGSAX	SEGSAX	SEGSAX	SEGSBX	SEGSBX	SEGSBX	SEGSBX	SEGSAX	SEGSAX	SEGSAX	SEGSAX

- Note1) In the 256-color mode, the vacant LSB bit is filled with "1".
- Note2) The function of 256-color mode is different from that of fixed 8-gradation mode (fixed 256-color mode).
- Note3) The written data in the DD RAM in "C256"=0 is not compatible with the data in "C256"=1.
- Note4) In the 256-color mode, only 8-bit length mode is available, but 16-bit is not.
- Note5) In 8-bit access mode(C256 mode) for DDRAM, sequential twice accesses to DDRAM complete one pixel data access. Therefore, it must be accessed with a couple of operation.
- Note6) In 8-bit access mode(non C256 mode) for DDRAM, After address set up display data will be written in an order from lower to higher.
This order has no relation with address direction of RAM access (Display rotation)

(7) Window addressing mode

Window area must be designated before RAM access.

In the window addressing mode, the address space of the DDRAM designated by the start and end point is defined. The start point is determined by the "column address" and "row address" instructions, and the end point is determined by the "Window end column address" and "Window end row address" instructions. The setting for the window addressing is listed in the following.

1. "Increment control" instruction set (HV, XD, YD)
2. Set the start point by the "column address" and "row address" instructions
3. Set the end point by the "Window end column address" and "Window end row address" instructions
4. Enable to access to the DDRAM in the window addressing mode

In addition, the read-modify-write operation is available by setting "AIM" register to "L" in the "Increment control" instruction.

For the window area designation, the address directions of RAM (HV, XD, YD) must be set first, and Column address and Row of Start point must be set second, Column address and Row of Stop point must be set third, then RAM should be accessed. Low address must be set first and High address must be set second in all of addresses. The directions of HV, XD, YD should be check to keep the area in RAM.

And in the window addressing mode, the following start and end point must be maintained to abide a malfunction.

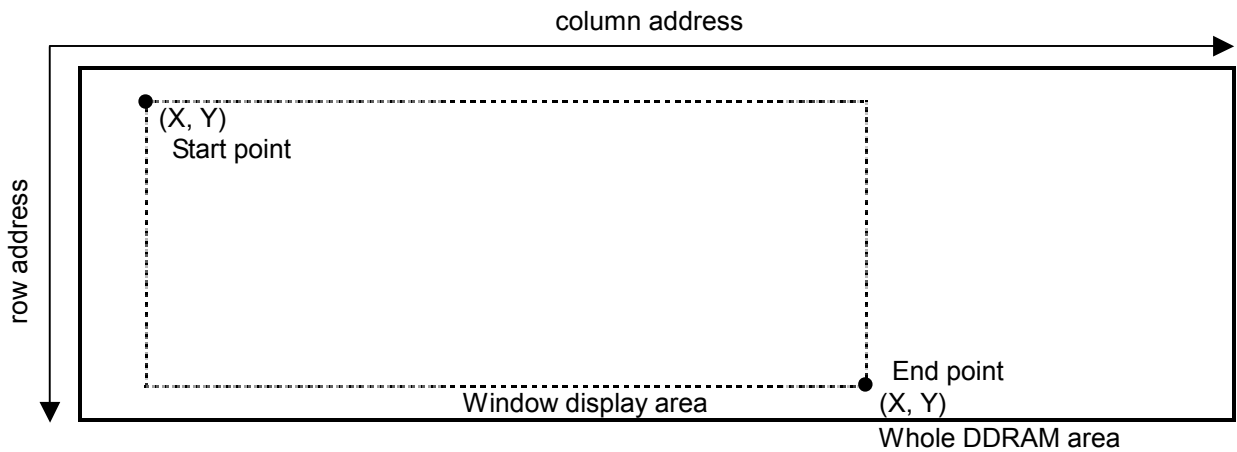

Fig7

(8) Reverse display ON/OFF

The "Reverse display ON/OFF" function is used to reverse the display data without changing the contents of the DDRAM.

Table9

REV	Display	DDRAM data → Display data	
0	Normal	0	0
		1	1
1	Reverse	0	1
		1	0

(9) Address directions of RAM access (Display rotation)

The bellow picture shows display image after set of HV, XD and YD for address directions. The display data from CPU can be written into RAM with rotation to 90 degrees or 180 degrees or 270 degrees, and also mirrored.

The address directions of RAM access is set by HV, XD and YD.

* : The segments of Icon are not rotated.

No.	HV	XD	YD	Data writing direction	Display image	Valid address
1	0	0	0			$X_s < X_e$ $Y_s < Y_e$
2	0	0	1			$X_s < X_e$ $Y_s > Y_e$
3	0	1	0			$X_s > X_e$ $Y_s < Y_e$
4	0	1	1			$X_s > X_e$ $Y_s > Y_e$
5	1	0	0			$X_s < X_e$ $Y_s < Y_e$
6	1	0	1			$X_s < X_e$ $Y_s > Y_e$
7	1	1	0			$X_s > X_e$ $Y_s < Y_e$
8	1	1	1			$X_s > X_e$ $Y_s > Y_e$

*:The display image shows the display direction when the same data as No.1 are written into RAM for condition change.

*: The outside address of RAM must not be set for correct operation.

Xs : start address of X , Ys : Start address of Y, Xe : End address of X, Ye : End address of Y

(10) The relationship among the DDRAM column address, display data and segment drivers

In the color mode, and 16-bit data bus mode

ABS	SWAP	Column address / bit / segment assign																								
0	0	X=00 _H												↔	X=7F _H											
		D ₁₅	D ₁₄	D ₁₃	D ₁₂	D ₁₀	D ₉	D ₈	D ₇	D ₄	D ₃	D ₂	D ₁	↕	D ₁₅	D ₁₄	D ₁₃	D ₁₂	D ₁₀	D ₉	D ₈	D ₇	D ₄	D ₃	D ₂	D ₁
		palette A				palette B				palette C				↕	palette A				palette B				palette C			
		SEGA ₀				SEGB ₀				SEGC ₀				↕	SEGA ₁₂₇				SEGB ₁₂₇				SEGC ₁₂₇			

ABS	SWAP	Column address / bit / segment assign																								
0	1	X=00 _H												↔	X=7F _H											
		D ₁₅	D ₁₄	D ₁₃	D ₁₂	D ₁₀	D ₉	D ₈	D ₇	D ₄	D ₃	D ₂	D ₁	↕	D ₁₅	D ₁₄	D ₁₃	D ₁₂	D ₁₀	D ₉	D ₈	D ₇	D ₄	D ₃	D ₂	D ₁
		palette A				palette B				palette C				↕	palette A				palette B				palette C			
		SEGC ₀				SEGB ₀				SEGA ₀				↕	SEGC ₁₂₇				SEGB ₁₂₇				SEGA ₁₂₇			

ABS	SWAP	Column address / bit / segment assign																								
1	0	X=00 _H												↔	X=7F _H											
		D ₁₁	D ₁₀	D ₉	D ₈	D ₇	D ₆	D ₅	D ₄	D ₃	D ₂	D ₁	D ₀	↕	D ₁₁	D ₁₀	D ₉	D ₈	D ₇	D ₆	D ₅	D ₄	D ₃	D ₂	D ₁	D ₀
		palette A				palette B				palette C				↕	palette A				palette B				palette C			
		SEGA ₀				SEGB ₀				SEGC ₀				↕	SEGA ₁₂₇				SEGB ₁₂₇				SEGC ₁₂₇			

ABS	SWAP	Column address / bit / segment assign																								
1	1	X=00 _H												↔	X=7F _H											
		D ₁₁	D ₁₀	D ₉	D ₈	D ₇	D ₆	D ₅	D ₄	D ₃	D ₂	D ₁	D ₀	↕	D ₁₁	D ₁₀	D ₉	D ₈	D ₇	D ₆	D ₅	D ₄	D ₃	D ₂	D ₁	D ₀
		palette A				palette B				palette C				↕	palette A				palette B				palette C			
		SEGC ₀				SEGB ₀				SEGA ₀				↕	SEGC ₁₂₇				SEGB ₁₂₇				SEGA ₁₂₇			

In the color mode, and 8-bit data bus mode

ABS	SWAP	Column address / bit / segment assign																									
0	0	X=00 _H (Upper)					X=00 _H (Lower)					↔	X=7F _H (Upper)					X=7F _H (Lower)									
		D ₇	D ₆	D ₅	D ₄	D ₂	D ₁	D ₀	D ₇	D ₄	D ₃	D ₂	D ₁	↕	D ₇	D ₆	D ₅	D ₄	D ₂	D ₁	D ₀	D ₇	D ₄	D ₃	D ₂	D ₁	
		palette A					palette B						palette A					palette B					palette C				
		SEGA ₀					SEGB ₀						SEGA ₁₂₇					SEGB ₁₂₇					SEGC ₁₂₇				

ABS	SWAP	Column address / bit / segment assign																									
0	1	X=00 _H (Upper)					X=00 _H (Lower)					↔	X=7F _H (Upper)					X=7F _H (Lower)									
		D ₇	D ₆	D ₅	D ₄	D ₂	D ₁	D ₀	D ₇	D ₄	D ₃	D ₂	D ₁	↕	D ₇	D ₆	D ₅	D ₄	D ₂	D ₁	D ₀	D ₇	D ₄	D ₃	D ₂	D ₁	
		palette A					palette B						palette A					palette B					palette C				
		SEGC ₀					SEGB ₀						SEGC ₁₂₇					SEGB ₁₂₇					SEGA ₁₂₇				

ABS	SWAP	Column address / bit / segment assign																																
1	0	X=00 _H (Upper)				X=00 _H (Lower)								↔	X=7F _H (Upper)				X=7F _H (Lower)															
		D ₃	D ₂	D ₁	D ₀	D ₇	D ₆	D ₅	D ₄	D ₃	D ₂	D ₁	D ₀	↕	D ₃	D ₂	D ₁	D ₀	D ₇	D ₆	D ₅	D ₄	D ₃	D ₂	D ₁	D ₀								
		palette A				palette B									palette A				palette B								palette C							
		SEGA ₀				SEGB ₀									SEGA ₁₂₇				SEGB ₁₂₇								SEGC ₁₂₇							

ABS	SWAP	Column address / bit / segment assign																																
1	1	X=00 _H (Upper)				X=00 _H (Lower)								↔	X=7F _H (Upper)				X=7F _H (Lower)															
		D ₃	D ₂	D ₁	D ₀	D ₇	D ₆	D ₅	D ₄	D ₃	D ₂	D ₁	D ₀	↕	D ₃	D ₂	D ₁	D ₀	D ₇	D ₆	D ₅	D ₄	D ₃	D ₂	D ₁	D ₀								
		palette A				palette B									palette A				palette B								palette C							
		SEGC ₀				SEGB ₀									SEGC ₁₂₇				SEGB ₁₂₇								SEGA ₁₂₇							

In the color mode, 8-bit data bus mode, and C256 mode (C256=1)

ABS	SWAP	Column address / bit / segment assign																		
*	0	X=00 _H									↔	X=7F _H								
		D ₇	D ₆	D ₅	D ₄	D ₃	D ₂	D ₁	D ₀	↔	D ₇	D ₆	D ₅	D ₄	D ₃	D ₂	D ₁	D ₀		
		palette A			palette B			palette C			↔	palette A			palette B			palette C		
		SEGA ₀			SEGB ₀			SEGC ₀			↔	SEGA ₁₂₇			SEGB ₁₂₇			SEGC ₁₂₇		

ABS	SWAP	Column address / bit / segment assign																		
*	1	X=00 _H									↔	X=7F _H								
		D ₇	D ₆	D ₅	D ₄	D ₃	D ₂	D ₁	D ₀	↔	D ₇	D ₆	D ₅	D ₄	D ₃	D ₂	D ₁	D ₀		
		palette A			palette B			palette C			↔	palette A			palette B			palette C		
		SEGC ₀			SEGB ₀			SEGA ₀			↔	SEGC ₁₂₇			SEGB ₁₂₇			SEGA ₁₂₇		

In the B&W mode, and 8-bit data bus mode

ABS	SWAP	Column address / bit / segment assign																								
0	0	X=00 _H (Upper)					X=00 _H (Lower)					↔	X=7F _H (Upper)					X=7F _H (Lower)								
		D ₇	D ₆	D ₅	D ₄	D ₂	D ₁	D ₀	D ₇	D ₄	D ₃	D ₂	D ₁	↕	D ₇	D ₆	D ₅	D ₄	D ₂	D ₁	D ₀	D ₇	D ₄	D ₃	D ₂	D ₁
		SEGA ₀					SEGB ₀						SEGA ₁₂₇					SEGB ₁₂₇								

ABS	SWAP	Column address / bit / segment assign																								
0	1	X=00 _H (Upper)					X=00 _H (Lower)					↔	X=7F _H (Upper)					X=7F _H (Lower)								
		D ₇	D ₆	D ₅	D ₄	D ₂	D ₁	D ₀	D ₇	D ₄	D ₃	D ₂	D ₁	↕	D ₇	D ₆	D ₅	D ₄	D ₂	D ₁	D ₀	D ₇	D ₄	D ₃	D ₂	D ₁
		SEGC ₀					SEGB ₀						SEGC ₁₂₇					SEGB ₁₂₇								

ABS	SWAP	Column address / bit / segment assign																								
1	0	X=00 _H (Upper)				X=00 _H (Lower)								↔	X=7F _H (Upper)				X=7F _H (Lower)							
		D ₃	D ₂	D ₁	D ₀	D ₇	D ₆	D ₅	D ₄	D ₃	D ₂	D ₁	D ₀	↕	D ₃	D ₂	D ₁	D ₀	D ₇	D ₆	D ₅	D ₄	D ₃	D ₂	D ₁	D ₀
		SEGA ₀				SEGB ₀									SEGA ₁₂₇				SEGB ₁₂₇							

ABS	SWAP	Column address / bit / segment assign																								
1	1	X=00 _H (Upper)				X=00 _H (Lower)								↔	X=7F _H (Upper)				X=7F _H (Lower)							
		D ₃	D ₂	D ₁	D ₀	D ₇	D ₆	D ₅	D ₄	D ₃	D ₂	D ₁	D ₀	↕	D ₃	D ₂	D ₁	D ₀	D ₇	D ₆	D ₅	D ₄	D ₃	D ₂	D ₁	D ₀
		SEGC ₀				SEGB ₀									SEGC ₁₂₇				SEGB ₁₂₇							

Bit assignments between write and read data (in the 16-bit data bus mode)

ABS=0

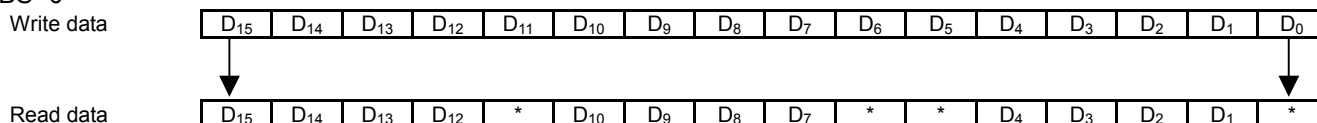

ABS=1

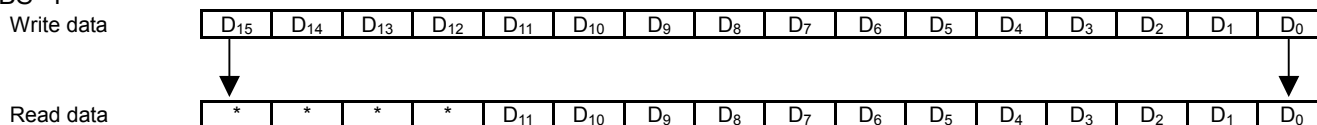

Examples of write and read data (In the 8 bit bus mode)

ABS=0, C256=0

(Address; Upper bit)

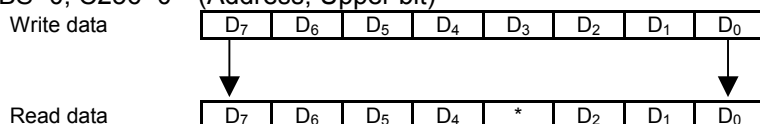

ABS=0, C256=0

(Address; Lower bit)

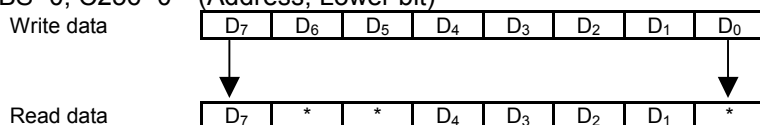

ABS=1, C256=0

(Address; Upper bit)

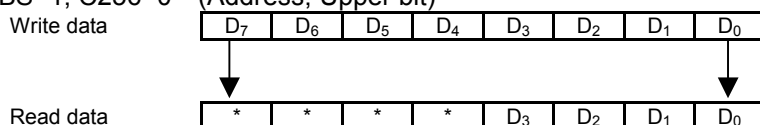

ABS=1, C256=0

(Address; Lower bit)

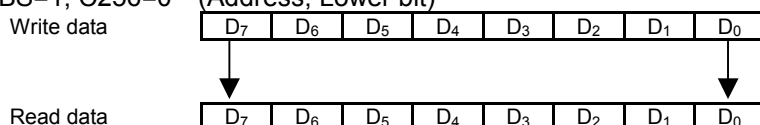

ABS=0, C256=1

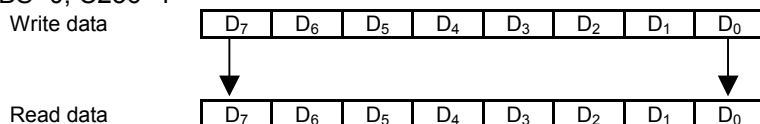

*: Invalid Data

Icon segment register address bit assignment

In the color mode, and 16-bit data bus mode

ABS	SWAP	Column address / bit / segment assign																							
0	0	X=00 _H								X=01 _H															
		D ₁₅	D ₁₄	D ₁₃	D ₁₂	D ₁₀	D ₉	D ₈	D ₇	D ₄	D ₃	D ₂	D ₁	D ₁₅	D ₁₄	D ₁₃	D ₁₂	D ₁₀	D ₉	D ₈	D ₇	D ₄	D ₃	D ₂	D ₁
		palette A				palette B				palette C				palette A				palette B				palette C			
		SEGS _{A0}				SEGS _{B0}				SEGS _{C0}				SEGS _{A1}				SEGS _{B1}				SEGS _{C1}			

ABS	SWAP	Column address / bit / segment assign																							
0	1	X=00 _H								X=01 _H															
		D ₁₅	D ₁₄	D ₁₃	D ₁₂	D ₁₀	D ₉	D ₈	D ₇	D ₄	D ₃	D ₂	D ₁	D ₁₅	D ₁₄	D ₁₃	D ₁₂	D ₁₀	D ₉	D ₈	D ₇	D ₄	D ₃	D ₂	D ₁
		palette A				palette B				palette C				palette A				palette B				palette C			
		SEGS _{C0}				SEGS _{B0}				SEGS _{A0}				SEGS _{C1}				SEGS _{B1}				SEGS _{A1}			

ABS	SWAP	Column address / bit / segment assign																							
1	0	X=00 _H								X=01 _H															
		D ₁₁	D ₁₀	D ₉	D ₈	D ₇	D ₆	D ₅	D ₄	D ₃	D ₂	D ₁	D ₀	D ₁₁	D ₁₀	D ₉	D ₈	D ₇	D ₆	D ₅	D ₄	D ₃	D ₂	D ₁	D ₀
		palette A				palette B				palette C				palette A				palette B				palette C			
		SEGS _{A0}				SEGS _{B0}				SEGS _{C0}				SEGS _{A1}				SEGS _{B1}				SEGS _{C1}			

ABS	SWAP	Column address / bit / segment assign																							
1	1	X=00 _H								X=01 _H															
		D ₁₁	D ₁₀	D ₉	D ₈	D ₇	D ₆	D ₅	D ₄	D ₃	D ₂	D ₁	D ₀	D ₁₁	D ₁₀	D ₉	D ₈	D ₇	D ₆	D ₅	D ₄	D ₃	D ₂	D ₁	D ₀
		palette A				palette B				palette C				palette A				palette B				palette C			
		SEGS _{C0}				SEGS _{B0}				SEGS _{A0}				SEGS _{C1}				SEGS _{B1}				SEGS _{A1}			

In the color mode, and 8-bit data bus mode

ABS	SWAP	Column address / bit / segment assign																															
0	0	X=00 _H (Upper)								X=00 _H (Lower)								X=01 _H (Upper)								X=01 _H (Lower)							
		D ₇	D ₆	D ₅	D ₄	D ₂	D ₁	D ₀	D ₇	D ₄	D ₃	D ₂	D ₁	D ₇	D ₆	D ₅	D ₄	D ₂	D ₁	D ₀	D ₇	D ₄	D ₃	D ₂	D ₁								
		palette A				palette B				palette C				palette A				palette B				palette C											
		SEGSA ₀				SEGSB ₀				SEGSC ₀				SEGSA ₁				SEGSB ₁				SEGSC ₁											

ABS	SWAP	Column address / bit / segment assign																															
0	1	X=00 _H (Upper)								X=00 _H (Lower)								X=01 _H (Upper)								X=01 _H (Lower)							
		D ₇	D ₆	D ₅	D ₄	D ₂	D ₁	D ₀	D ₇	D ₄	D ₃	D ₂	D ₁	D ₇	D ₆	D ₅	D ₄	D ₂	D ₁	D ₀	D ₇	D ₄	D ₃	D ₂	D ₁								
		palette A				palette B				palette C				palette A				palette B				palette C											
		SEGSC ₀				SEGSB ₀				SEGSA ₀				SEGSC ₁				SEGSB ₁				SEGSA ₁											

ABS	SWAP	Column address / bit / segment assign																											
1	0	X=00 _H (Upper)				X=00 _H (Lower)								X=01 _H (Upper)								X=01 _H (Lower)							
		D ₃	D ₂	D ₁	D ₀	D ₇	D ₆	D ₅	D ₄	D ₃	D ₂	D ₁	D ₀	D ₃	D ₂	D ₁	D ₀	D ₇	D ₆	D ₅	D ₄	D ₃	D ₂	D ₁	D ₀				
		palette A				palette B				palette C				palette A				palette B				palette C							
		SEGSA ₀				SEGSB ₀				SEGSC ₀				SEGSA ₁				SEGSB ₁				SEGSC ₁							

ABS	SWAP	Column address / bit / segment assign																											
1	1	X=00 _H (Upper)				X=00 _H (Lower)								X=01 _H (Upper)								X=01 _H (Lower)							
		D ₃	D ₂	D ₁	D ₀	D ₇	D ₆	D ₅	D ₄	D ₃	D ₂	D ₁	D ₀	D ₃	D ₂	D ₁	D ₀	D ₇	D ₆	D ₅	D ₄	D ₃	D ₂	D ₁	D ₀				
		palette A				palette B				palette C				palette A				palette B				palette C							
		SEGSC ₀				SEGSB ₀				SEGSA ₀				SEGSC ₁				SEGSB ₁				SEGSA ₁							

In the B/W mode, and 16-bit data bus mode

ABS	SWAP	Column address / bit / segment assign																																	
0	0	X=00 _H								X=01 _H																									
		D ₁₅	D ₁₄	D ₁₃	D ₁₂	D ₁₁	D ₁₀	D ₉	D ₈	D ₇	D ₆	D ₅	D ₄	D ₃	D ₂	D ₁	D ₀	D ₁₅	D ₁₄	D ₁₃	D ₁₂	D ₁₁	D ₁₀	D ₉	D ₈	D ₇	D ₆	D ₅	D ₄	D ₃	D ₂	D ₁	D ₀		
		SEGS _{A0}	SEGS _{B0}	SEGS _{C0}	SEGS _{A1}	SEGS _{B1}	SEGS _{C1}

ABS	SWAP	Column address / bit / segment assign																															
0	1	X=00 _H								X=01 _H																							
		D ₁₅	D ₁₄	D ₁₃	D ₁₂	D ₁₁	D ₁₀	D ₉	D ₈	D ₇	D ₆	D ₅	D ₄	D ₃	D ₂	D ₁	D ₀	D ₁₅	D ₁₄	D ₁₃	D ₁₂	D ₁₁	D ₁₀	D ₉	D ₈	D ₇	D ₆	D ₅	D ₄	D ₃	D ₂	D ₁	D ₀
		SEGS _{C0}	SEGS _{B0}	SEGS _{A0}	SEGS _{C1}	SEGS _{B1}	SEGS _{A1}

ABS	SWAP	Column address / bit / segment assign																															
1	0	X=00 _H								X=01 _H																							
		D ₁₅	D ₁₄	D ₁₃	D ₁₂	D ₁₁	D ₁₀	D ₉	D ₈	D ₇	D ₆	D ₅	D ₄	D ₃	D ₂	D ₁	D ₀	D ₁₅	D ₁₄	D ₁₃	D ₁₂	D ₁₁	D ₁₀	D ₉	D ₈	D ₇	D ₆	D ₅	D ₄	D ₃	D ₂	D ₁	D ₀
		SEGS _{A0}	SEGS _{B0}	SEGS _{C0}	SEGS _{A1}	SEGS _{B1}	SEGS _{C1}

ABS	SWAP	Column address / bit / segment assign																															
1	1	X=00 _H								X=01 _H																							
		D ₁₅	D ₁₄	D ₁₃	D ₁₂	D ₁₁	D ₁₀	D ₉	D ₈	D ₇	D ₆	D ₅	D ₄	D ₃	D ₂	D ₁	D ₀	D ₁₅	D ₁₄	D ₁₃	D ₁₂	D ₁₁	D ₁₀	D ₉	D ₈	D ₇	D ₆	D ₅	D ₄	D ₃	D ₂	D ₁	D ₀
		SEGS _{C0}	SEGS _{B0}	SEGS _{A0}	SEGS _{C1}	SEGS _{B1}	SEGS _{A1}

In the B/W mode, and 8-bit data bus mode

ABS	SWAP	Column address / bit / segment assign																							
0	0	X=00 _H (Upper)					X=00 _H (Lower)					X=01 _H (Upper)					X=01 _H (Lower)								
		D ₇	D ₆	D ₅	D ₄	D ₂	D ₁	D ₀	D ₇	D ₄	D ₃	D ₂	D ₁	D ₇	D ₆	D ₅	D ₄	D ₂	D ₁	D ₀	D ₇	D ₄	D ₃	D ₂	D ₁
		SEGS _{A0}				SEGS _{B0}				SEGS _{C0}				SEGS _{A1}				SEGS _{B1}				SEGS _{C1}			

ABS	SWAP	Column address / bit / segment assign																							
0	1	X=00 _H (Upper)					X=00 _H (Lower)					X=01 _H (Upper)					X=01 _H (Lower)								
		D ₇	D ₆	D ₅	D ₄	D ₂	D ₁	D ₀	D ₇	D ₄	D ₃	D ₂	D ₁	D ₇	D ₆	D ₅	D ₄	D ₂	D ₁	D ₀	D ₇	D ₄	D ₃	D ₂	D ₁
		SEGS _{C0}				SEGS _{B0}				SEGS _{A0}				SEGS _{C1}				SEGS _{B1}				SEGS _{A1}			

ABS	SWAP	Column address / bit / segment assign																							
1	0	X=00 _H (Upper)				X=00 _H (Lower)				X=01 _H (Upper)				X=01 _H (Lower)											
		D ₃	D ₂	D ₁	D ₀	D ₇	D ₆	D ₅	D ₄	D ₃	D ₂	D ₁	D ₀	D ₃	D ₂	D ₁	D ₀	D ₇	D ₆	D ₅	D ₄	D ₃	D ₂	D ₁	D ₀
		SEGS _{A0}				SEGS _{B0}				SEGS _{C0}				SEGS _{A1}				SEGS _{B1}				SEGS _{C1}			

ABS	SWAP	Column address / bit / segment assign																							
1	1	X=00 _H (Upper)				X=00 _H (Lower)				X=01 _H (Upper)				X=01 _H (Lower)											
		D ₃	D ₂	D ₁	D ₀	D ₇	D ₆	D ₅	D ₄	D ₃	D ₂	D ₁	D ₀	D ₃	D ₂	D ₁	D ₀	D ₇	D ₆	D ₅	D ₄	D ₃	D ₂	D ₁	D ₀
		SEGS _{C0}				SEGS _{B0}				SEGS _{A0}				SEGS _{C1}				SEGS _{B1}				SEGS _{A1}			

(11) Gradation palette

In the gradation mode, either variable or fixed gradation mode is selected by programming the "PWM" register of the "Gradation control" instruction.

PWM=0: Variable gradation mode
(Select 16 gradation levels out of 32-gradation level of the gradation palette)

PWM=1: Fixed gradation mode
(Fixed 8-gradation levels)

In these modes, each of the gradation palettes Aj, Bj and Cj can select 16-gradation level out of 32-gradation level by setting 5-bit data to the "PA" registers in the "Gradation palette j" instructions (j=0 to Fh).

For instance, the gradation palettes Aj correspond to the SEGAI, the Bj to SEGBi and the Cj to SEGCi (j=0 to 15, i=0 to 127).

Correspondence between display data and gradation palettes

Table 10 (Palette Aj, Palette Bj, Palette Cj (j=0 to 15))

(MSB) Display data (LSB)				Gradation palette	Default palette value
0	0	0	0	Palette 0	0 0 0 0
0	0	0	1	Palette 1	0 0 0 1
0	0	1	0	Palette 2	0 0 1 0
0	0	1	1	Palette 3	0 0 1 1
0	1	0	0	Palette 4	0 1 0 0
0	1	0	1	Palette 5	0 1 0 1
0	1	1	0	Palette 6	0 1 1 0
0	1	1	1	Palette 7	0 1 1 1
1	0	0	0	Palette 8	1 0 0 0
1	0	0	1	Palette 9	1 0 0 1
1	0	1	0	Palette10	1 0 1 0
1	0	1	1	Palette11	1 0 1 1
1	1	0	0	Palette12	1 1 0 0
1	1	0	1	Palette13	1 1 0 1
1	1	1	0	Palette14	1 1 1 0
1	1	1	1	Palette15	1 1 1 1

Gradation palette table (Variable gradation mode, PWM="0", MON="0")

Table 11 (Palette Aj, Palette Bj, Palette Cj (j=0 to 15))

Palette value	Gradation level	Gradation palette	Palette value	Gradation level	Gradation palette
0 0 0 0	0	Palette 0(default)	1 0 0 0	16/31	
0 0 0 1	1/31		1 0 0 1	17/31	Palette 0(default)8
0 0 0 1 0	2/31		1 0 0 1 0	18/31	
0 0 0 1 1	3/31	Palette 1(default)	1 0 0 1 1	19/31	Palette 9(default)
0 0 1 0 0	4/31		1 0 1 0 0	20/31	
0 0 1 0 1	5/31	Palette 2(default)	1 0 1 0 1	21/31	Palette 10(default)
0 0 1 1 0	6/31		1 0 1 1 0	22/31	
0 0 1 1 1	7/31	Palette 3(default)	1 0 1 1 1	23/31	Palette 11(default)
0 1 0 0 0	8/31		1 1 0 0 0	24/31	
0 1 0 0 1	9/31	Palette 4(default)	1 1 0 0 1	25/31	Palette 12(default)
0 1 0 1 0	10/31		1 1 0 1 0	26/31	
0 1 0 1 1	11/31	Palette 5(default)	1 1 0 1 1	27/31	Palette 13(default)
0 1 1 0 0	12/31		1 1 1 0 0	28/31	
0 1 1 0 1	13/31	Palette 6(default)	1 1 1 0 1	29/31	Palette 14(default)
0 1 1 1 0	14/31		1 1 1 1 0	30/31	
0 1 1 1 1	15/31	Palette 7(default)	1 1 1 1 1	31/31	Palette 15(default)

Gradation palette table (Fixed gradation mode, PWM="1", MON="0")

Table 12 8-gradation segment drivers

(MSB) Display data (LSB)				Gradation level
0	0	0	*	0/7
0	0	1	*	1/7
0	1	0	*	2/7
0	1	1	*	3/7
1	0	0	*	4/7
1	0	1	*	5/7
1	1	0	*	6/7
1	1	1	*	7/7

(MSB) Display data (LSB)				Gradation level
0	0	*	*	0/7
0	0	*	*	
0	1	*	*	3/7
0	1	*	*	
1	0	*	*	5/7
1	0	*	*	
1	1	*	*	7/7
1	1	*	*	

Correspondence between display data and gradation level (B&W mode, MON="1")

Table 13

(MSB) Display data (LSB)				Gradation level
0	*	*	*	0
1	*	*	*	1

*:Don't care

(12) Gradation control and display data

(12-1) Gradation mode

In the gradation mode, each pixel for RGB corresponds to successive 3 segment drivers, and each segment driver provides 16-gradation PWM output by controlling 4 bit display data of the DDRAM. Accordingly, the LSI can drive up to 128x128 pixels in 4096-color (16-gradation x 16-gradation x 16-gradation = 4-bit x 4-bit x 4-bit).

In addition, the LSI can transfer the display data for the RGB by 16-bit at once or 8-bit two-times. The data assignment between gradation palettes and segment drivers varies in accordance with setting for the "SWAP" registers of the "Display control (2)" instruction.

- SWAP = 0

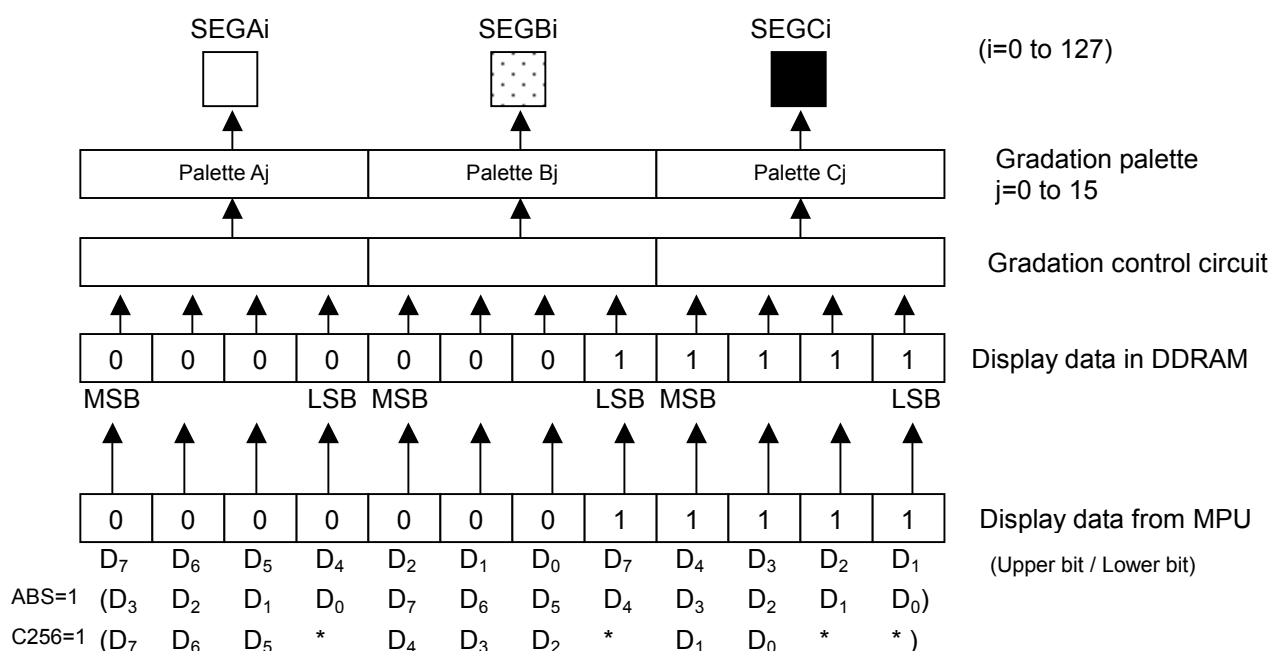

- SWAP = 1

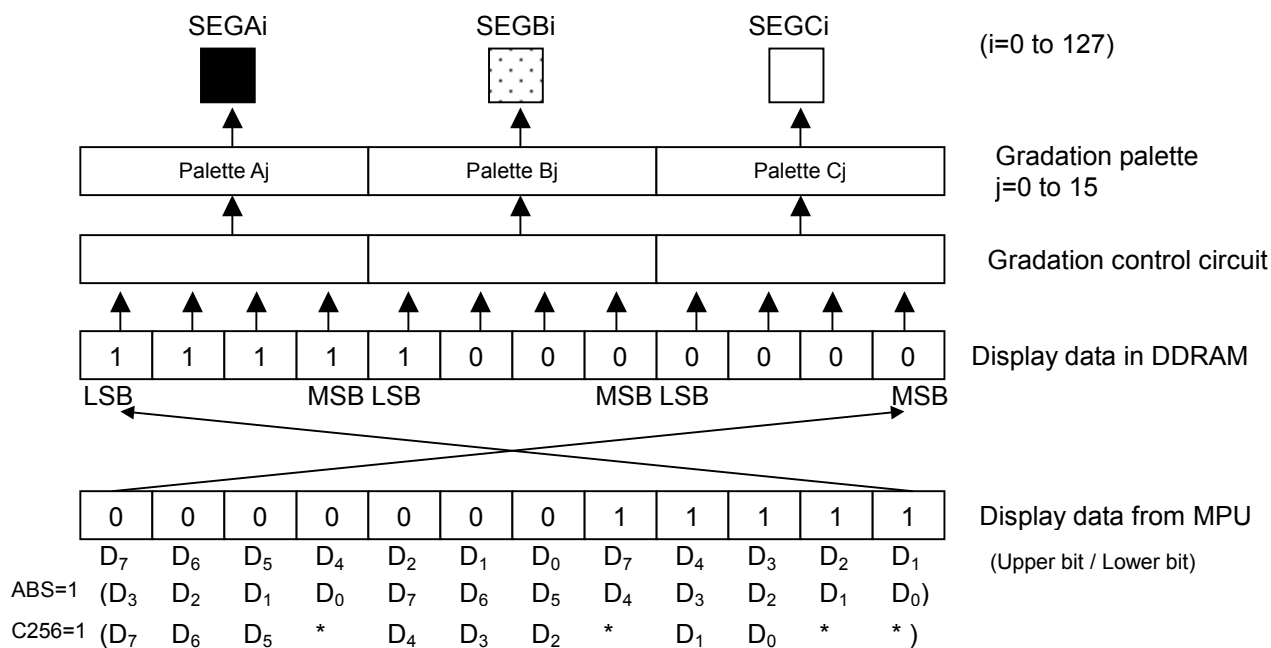

In the 16-bit data bus mode, the data assignments between the gradation palettes and the segment drivers vary in accordance with setting for the "SWAP" bit of the "Display control (2)" instruction as well as the assignment in the 8-bit data bus mode.

- SWAP = 0

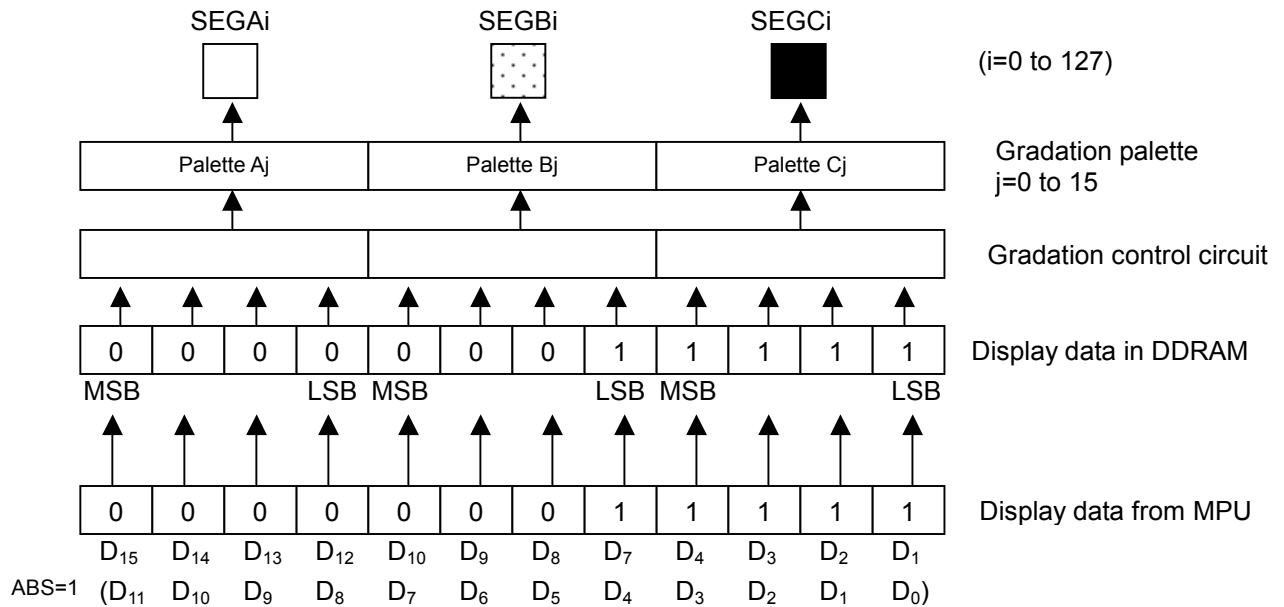

- SWAP = 1

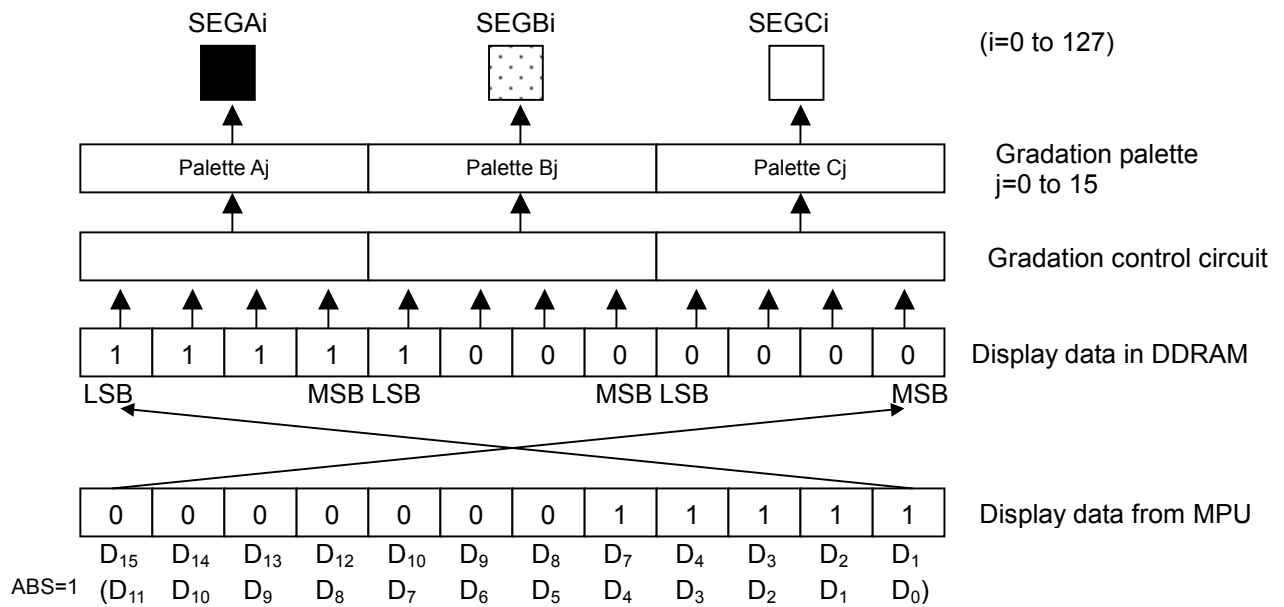

(12-2) B&W mode (MON="1")

In the B&W mode, 3 bits of the MSB data are used in both of the 16-bit and 8-bit data bus modes.

In the 16-bit data bus mode (Similarly 8-bit data bus access)

- SWAP = 0

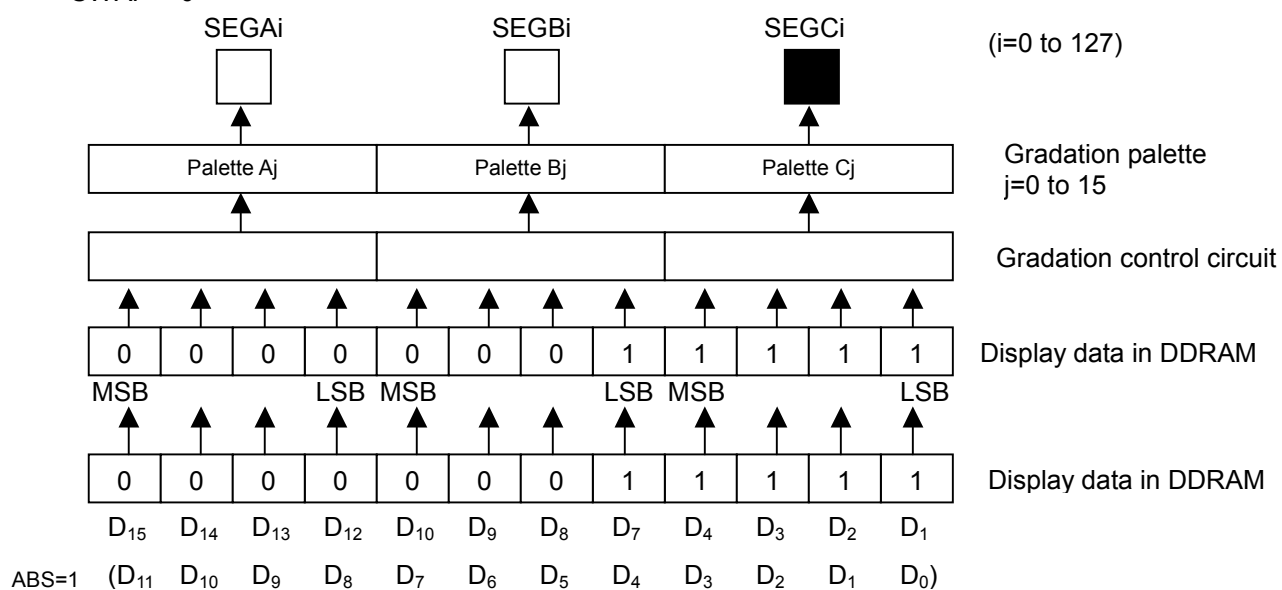

- SWAP = 1

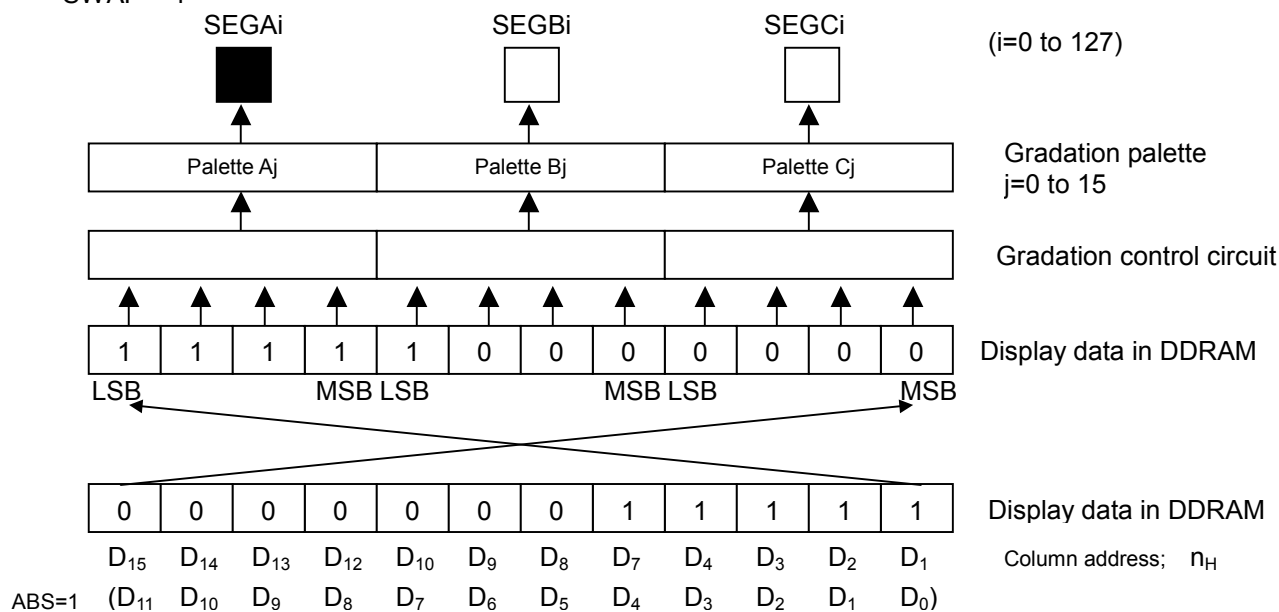

The correlation of display data with gradation control is also applied to Icon segment.

(13) Display timing generator

The display-timing generator creates the timing pulses such as the CL, the FLM, the FR and the CLK by dividing the oscillation frequency oscillate an external or internal resistor mode. The each of timing pulses is outputted through the each output terminals by "SON"=1.

(14) LCD line clock (CL)

The LCD line clock (CL) is used as a count-up signal for the line counter and a latch signal for the data latch circuit. At the rising edge of the CL signal, the line counter is counted-up and the 384-bit display data, corresponding to this line address, is latched into the data latch circuit. And at the falling edge of the CL signal, this latched data output on the segment drivers. Read out timing of the display data, from DDRAM to the latch circuits is completely independent of the access timing to the MPU. For this reason, the MPU can access to the LSI regardless of an internal operation.

(15) LCD alternate signal (FR) and LCD synchronous signal (FLM)

The FR and FLM signals are created from the CL signal. The FR signal is used to alternate the crystal polarization on a LCD panel. It is programmed that the FR signal is toggle on every frame in the default setting or once every N lines in the N-line inversion mode. The FLM signal is used to indicate a start line of a new display frame. It presets an initial display line address of the line counter when the FLM signal becomes "1".

(16) Data latch circuit

The data latch circuit is used temporarily store the display data that will output to the segment drivers. The display data in this circuit is updated in synchronization of the CL signal.

The "All pixels ON/OFF", "Display ON/OFF" and "Reverse display ON/OFF" instructions change the display data in this circuit but do not change the display data of the DDRAM.

(17) Common and segment drivers

The LSI includes 384+6-segment drivers and 128-common drivers. The common drivers generate the LCD driving waveforms composed of the V_{LCD} , V_1 , V_4 and V_{SS} in accordance with the FR signal and scanning data. The segment drivers generate waveforms composed of the V_{LCD} , V_2 , V_3 and V_{SS} in accordance with the FR signal and display data.

LCD Driving waveforms (In the B&W mode, Reverse display OFF, 1/129 duty)

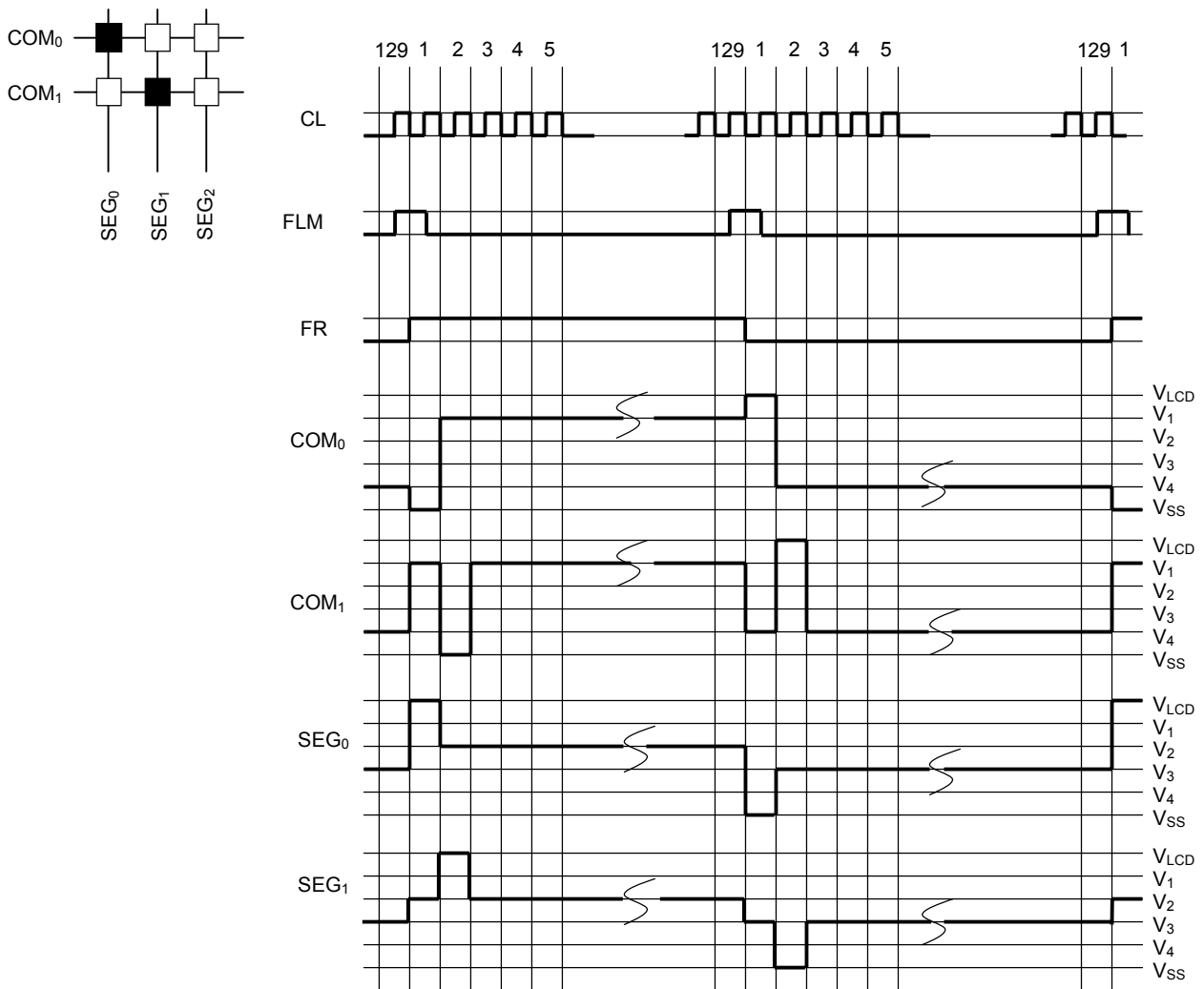

Fig 8

(18) Icon Segment Driver Circuit

Each 3 outputs (SEGSA0 to SEGSA1, SEGSB0 to SEGSB1, SEGSC0 to SEGSC1) placed at both edges of normal segment output terminals line are Segment outputs for Icon. Although normal Segment output generates the LCD driving voltage corresponding with the data in Display Data RAM, Icon segment driver provides the register instead of the display data RAM. The data corresponding to SEGSA0, SEGSB0 and SEGSC0 are in 12-bit register and output the same driving voltage on the row direction. (The data corresponding to SEGSA1, SEGSB1 and SEGSC1 are same as SEGSA0, SEGSB0 and SEGSC0.)

The outputs of SEGSA0 to SEGSA1 assign the same gradation pallet as SEGSA0 to SEGSA127, SEGSB0 to SEGSB1 are SEGSB0 to SEGSB127 and SEGSC0 to SEGSC1 are SEGSC0 to SEGSC127.

Icon Segment Driver Circuit operates for the outline frame display or background. These displays are changed in accordance with attribute of ALLON or REV command, but no change by LREV command.

The capacity of register corresponding with Icon segment driver (SEGSA0 to SEGSA1, SEGSB0 to SEGSB1, SEGSC0 to SEGSC1) is 24 bits. The access to from this register performed at DMY="1"..

Table14

RS	DMY	68type	80 type		Function
		R/W	\overline{RD}	\overline{WR}	
L	0	H	L	H	Display data read
L	0	L	H	L	Display data write
L	1	H	L	H	Icon segment register read
L	1	L	H	L	Icon segment register read

Read out function from the Icon segment register is restricted as same as the display data read out function from Display Data RAM. After address set, the addressed data does not come out by the first read instruction immediately but comes out by the second read instruction. Therefore, one dummy read out function is required for data read from Icon segment register after the address set or the data write operation.

When the Icon segment registers are accessed in DMY="1", the valid addressing is just a column address. Because of 24 bits Icon register, the valid addresses are "00h" and "01h" in 8-bit or 16-bit mode.

When the Icon segment registers are accessed in DMY="1", the data write operation into Icon register is enabled with the increment / decrement operation.

The column address increment operates as shown below. But the auto carry up operation like as the maximum address to "00h" does not operate of the display data RAM access.

00h -> Max.

- 8-bit or 16-bit data bus mode (DMY="1")

Column address	00 _H :	SEGSA ₀ , SEGSB ₀ , SEGSC ₀
	01 _H :	SEGSA ₁ , SEGSB ₁ , SEGSC ₁

Note) Refer the "Icon segment register address bit assignment" in (10) The relationship among the DDRAM column address, display data and segment drivers. Both of Icon segment register and Display data RAM operate a same address counter so that the address is set again in the status transition of DMY = "0" to "1" or "1" to "0".

The access to Icon register must be operated in the condition of HV=0.

Examples for the dummy segment registers (DMY="1")
(In the 16-bit data bus mode, gradation mode, (REF,SWAP)=(0,0))

Column address: 00_H

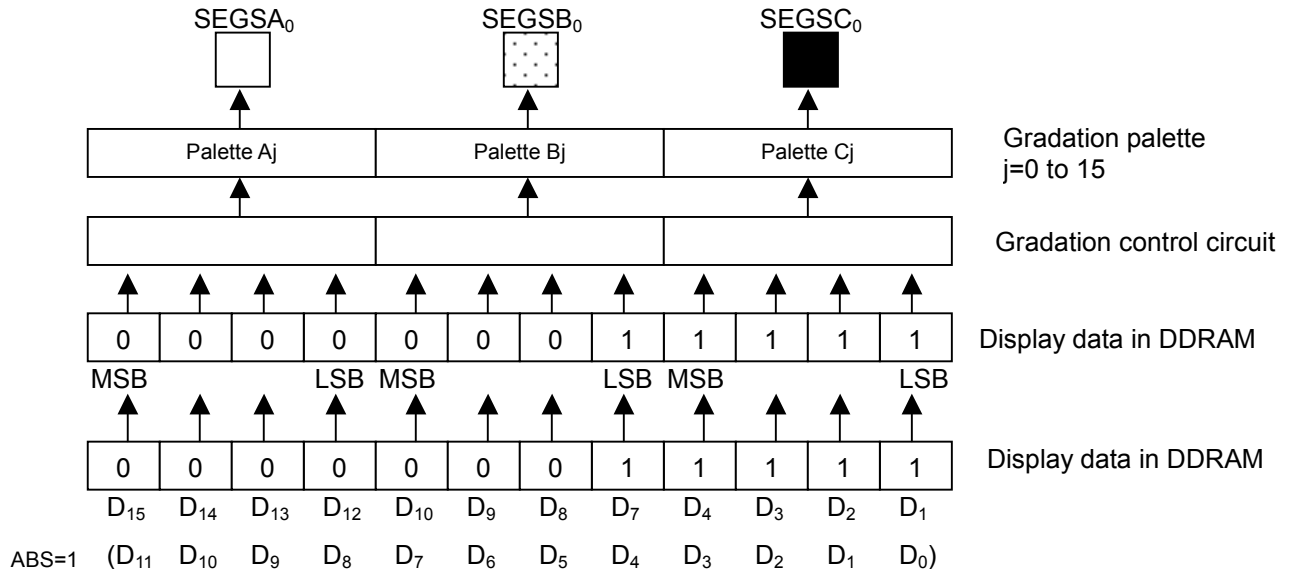

Column address: 01_H

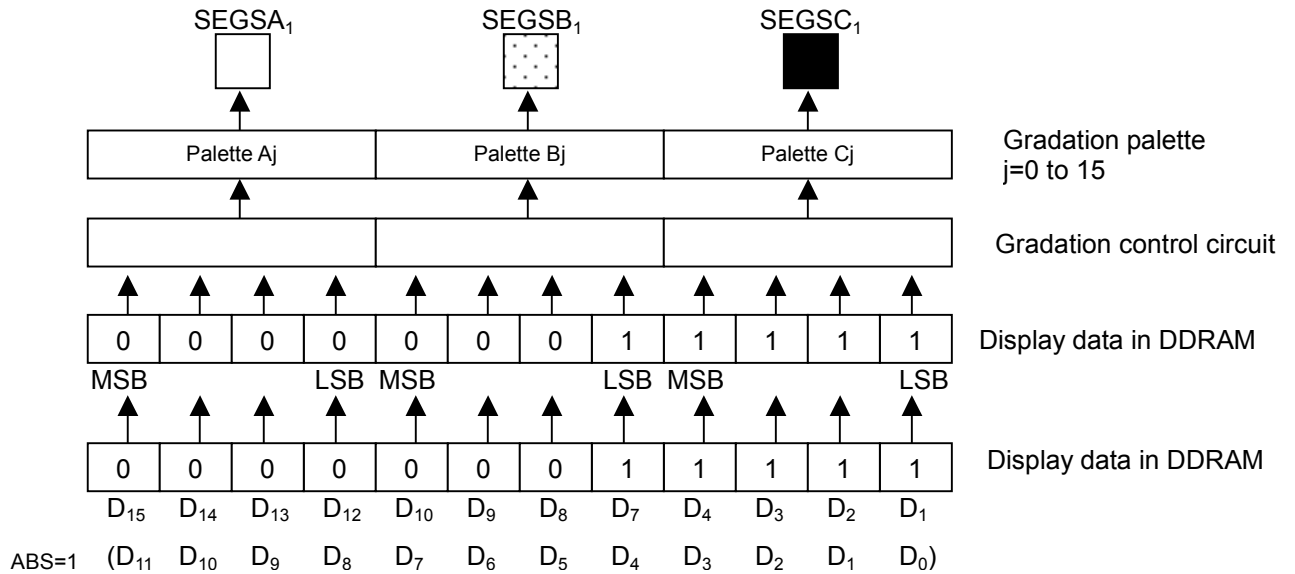

(19) Oscillator

The oscillator generates internal clocks for the display timing and the voltage booster. Since the LSI has internal capacitor (C) and resistor (R) for the oscillation, external capacitor and resistor are not usually required. However, in case that an external resistor is used, the resistor is connected between the OSC₁ and OSC₂ terminals. The external resistor becomes enabled by setting "1" to the "CKS" register of "Data bus length" instruction. When the internal oscillator is not used, the external clocks with 50% duty cycle ratio must be input to the OSC₁ terminal.

In addition, the feed back resistor for the oscillation is varied by programming the "Rf" register of the "Frequency control" instruction, so that it is possible to optimize the frame frequency for a LCD panel. Setting examples of the MON (B&W /Gradation) and the PWM (Variable gradation /Fixed gradation) are described, as follows.

Internal oscillation mode (CKS=0)

Symbol	MON	PWM	Display mode
f ₁	0	0	Variable gradation mode
f ₂	0	1	Fixed gradation mode
f ₃	1	*	B&W mode

*: Don't care

External resistor oscillation mode(CKS=1)

The internal clocks must be adjusted to the same frequency as the one in using the internal oscillation mode, and the "MON" and "PWM" registers must be set as well.

External clock input mode(CKS=1)

The external clocks must be adjusted to the same frequency as the one in using the internal oscillation mode, and the "MON" and "PWM" registers must be set as well.

(20) Power supply circuits

The internal power supply circuits are composed of the voltage booster, the electrical variable resistor (EVR), the voltage regulator, reference voltage generator and the voltage followers.

The condition of the power supply circuits is arranged by programming the "DCON" and "AMPON" registers on the "Power control" instruction. For this arrangement, some parts of the internal power supply circuits are activated in using an external power supply, as shown in the following table.

Table 15

DCON	AMPON	Voltage booster	Voltage followers Voltage regulator EVR	External voltage	Note
0	0	Disable	Disable	V _{OUT} , V _{LCD} , V ₁ , V ₂ , V ₃ , V ₄	1, 3
0	1	Disable	Enable	V _{OUT}	2, 3
1	1	Enable	Enable	-	-

Note1) The internal power circuits are not used. The external V_{OUT} is required and the C₁₊, C₁₋, C₂₊, C₂₋, C₃₊, C₃₋, C₄₊, C₄₋, C₅₊, C₅₋, V_{REF}, V_{REG} and V_{EE} terminals must be open.

Note2) The internal power circuits except the voltage booster are used. The external V_{OUT} is required and the C₁₊, C₁₋, C₂₊, C₂₋, C₃₊, C₃₋, C₄₊, C₄₋, C₅₊, C₅₋ and V_{EE} terminals must be open. The reference voltage is required to V_{REF} terminal.

Note3) The relation among the voltages should be maintained as follows.

$$V_{OUT} \geq V_{LCD} \geq V_1 \geq V_2 \geq V_3 \geq V_4 \geq V_{SS}$$

(21) Voltage booster

The voltage booster generates maximum 6x voltage of the V_{EE} level. It is programmed so that the boost level is selected out of 1x, 2x, 3x, 4x, 5x and 6x by the “Boost level select” instruction. The boosted voltage V_{OUT} must not exceed beyond the value of 18.0V, otherwise the voltage stress may cause a permanent damage to the LSI.

Boosted voltages

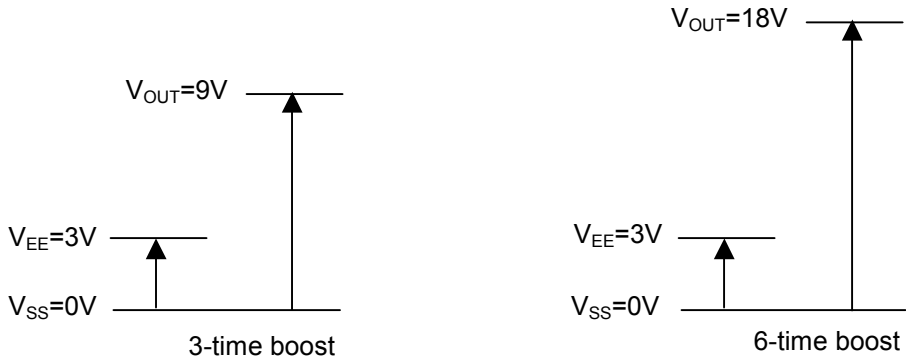

Capacitor connections for the voltage Booster

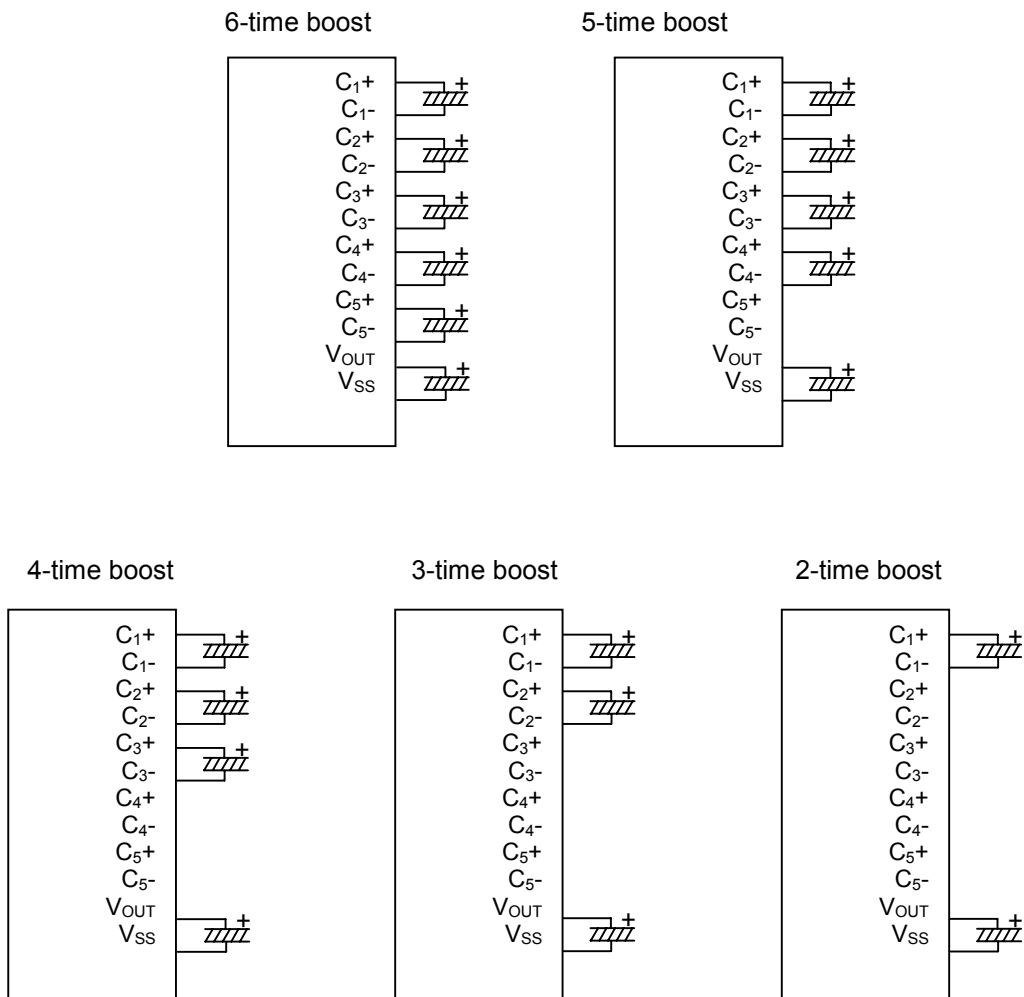

Fig 9

(22) Reference voltage generator

The reference voltage generator is used to produce the reference voltage (V_{BA}), which is output from the V_{BA} terminal and should be input to the V_{REF} terminal.

$$V_{BA} = V_{EE} \times 0.9$$

(23) Voltage regulator

The voltage regulator, composed of the gain control circuit and an operational amplifier, and is used to gain the reference voltage (V_{REF}) and to create the regulated voltage (V_{REG}). The V_{REG} is used as an input voltage to the EVR circuits, which is programmed by the "VU" register of the "Boost level" instruction.

$$V_{REG} = V_{REF} \times N \quad (N: \text{register value for the boost level})$$

(24) Electrical variable resistor (EVR)

The EVR is variable within 128-step, and is used to fine-tune the LCD driving voltage (V_{LCD}) by programming the "DV" register in the "EVR control" instruction, so that it is possible to optimize the contrast level for a LCD panels.

$$V_{LCD} = 0.5 \times V_{REG} + M (V_{REG} - 0.5 \times V_{REG}) / 127 \quad (M: \text{register value for the EVR})$$

(25) LCD driving voltage generation circuit

LCD driving voltage generation circuit generates the V_{LCD} voltage levels as V_{LCD} , V_1 , V_2 , V_3 and V_4 with internal E.V.R and the Bleeder resistors. The bias ratio of the LCD driving voltage is selected out of 1/5, 1/6, 1/7, 1/8, 1/9, 1/10, 1/11 and 1/12.

In using the internal power supply, the capacitors CA_2 must be connected to the V_{LCD} , V_1 , V_2 , V_3 and V_4 terminals, and the CA_2 value must be determined by the evaluation with actual LCD modules.

In using the external power supply, the external LCD driving voltages such as the V_{LCD} , V_1 , V_2 , V_3 and V_4 are supplied and the internal power supply circuits must be set to "OFF" by $DCON = AMPON = "0"$. In this mode, voltage booster terminals such as C_{1+} , C_{1-} , C_{2+} , C_{2-} , C_{3+} , C_{3-} , C_{4+} , C_{4-} , C_{5+} , C_{5-} , V_{EE} , V_{REF} and V_{REG} must be opened.

In case that the voltage booster is not used but only some parts of internal power supply circuits (Voltage followers, Voltage regulator and EVR) are used, the C_{1+} , C_{1-} , C_{2+} , C_{2-} , C_{3+} , C_{3-} , C_{4+} , C_{4-} , C_{5+} and C_{5-} terminals must be opened. And, the external power supply is input to the V_{OUT} terminal, and the reference voltage to the V_{REF} terminal. The capacitor CA_3 must connect to the V_{REG} terminal for voltage stabilization.

< Bias adjustment function >

NJU6824 prepares bias adjustment terminals V_1A_1 , V_1A_2 , V_4A_1 and V_4A_2 for fine adjustment of V_1 and V_4 out of voltages.

The status combination of V_1A_1 terminal and V_1A_2 can adjust V_1 voltage in below table and V_4A_1 and V_4A_2 can adjust V_4 voltage. These adjustment performs by the connection change between the Bleeder resistors and the output buffer operational amplifier as voltage follower circuit.

V_1A_1 terminal	V_1A_2 terminal	Fluctuation voltage [mV] *1
0	0	0
0	1	+5
1	0	-5
1	1	+10

V_4A_1 terminal	V_4A_2 terminal	Fluctuation voltage [mV] *1
0	0	0
0	1	+5
1	0	-5
1	1	-10

Note 1) The fluctuation voltage is a adjusted voltage against the default voltage at (V_1A_1 , $V_1A_2 = "0, 0"$ and V_4A_1 , $V_4A_2 = "0, 0"$). The "+" mark means a direction of voltage fluctuation to V_{LCD} and the "-" is to V_{SS} .

Note 2) The fluctuation voltage is an ideal value.

Note 3) The fluctuation voltage is at $V_{LCD}=13.5V$.

Note 4) "0" of V_1A_1 , V_1A_2 , V_4A_1 and V_4A_2 means V_{SS} and "1" means V_{DD} .

Connections of the capacitors for voltage boost

Using all of the internal power supply circuits
(6-time boost)

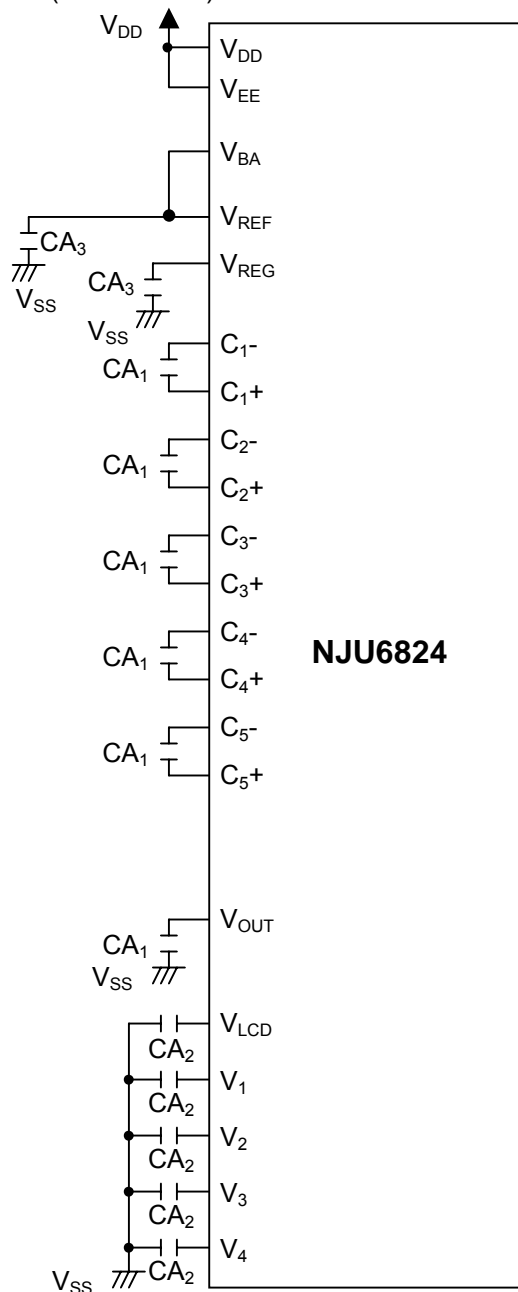

Fig 10

Using only external power supply circuits

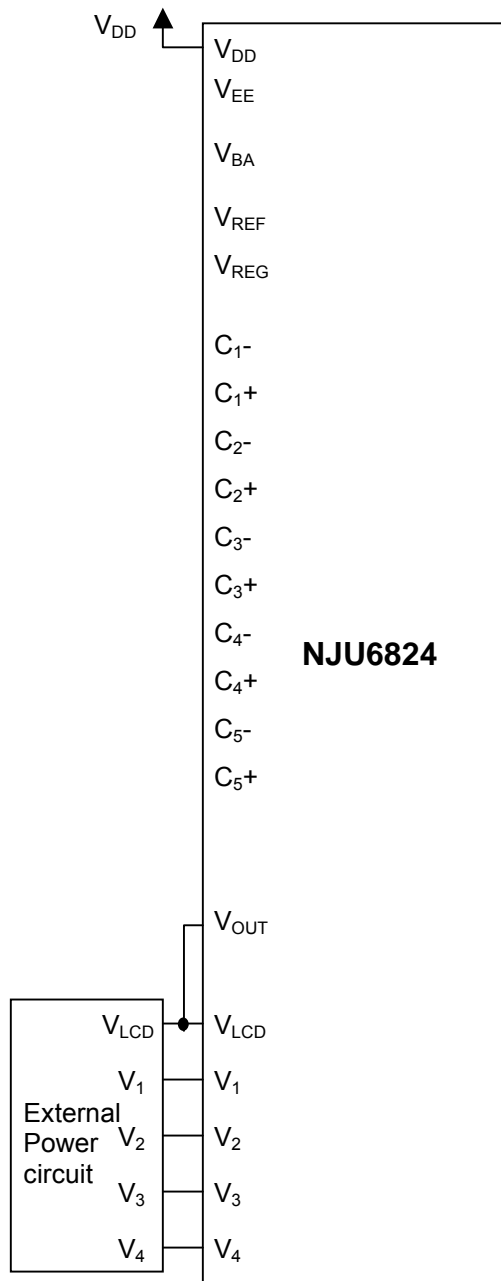

Fig11

Reference values

CA ₁	1.0 to 4.7uF
CA ₂	1.0 to 2.2uF
CA ₃	0.1uF

Note) B grade capacitors are required.

Using internal power supply circuits
Without the reference voltage generator(1)
(6-time boost)

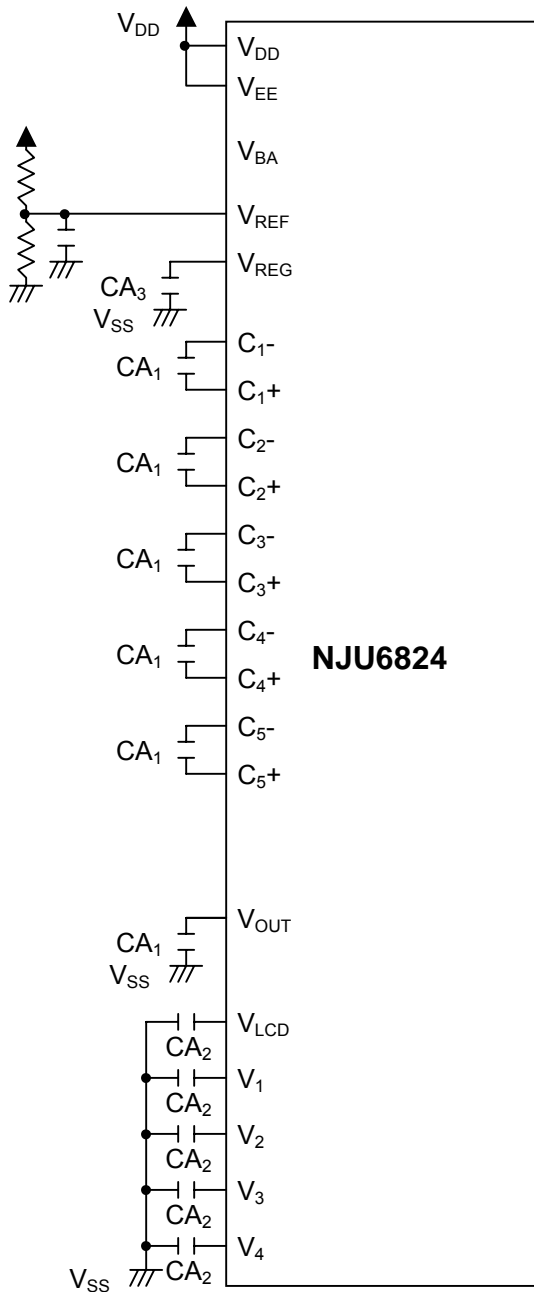

Fig 12

Using internal power supply circuit
Without the reference voltage generator(2)
(6-time boost)

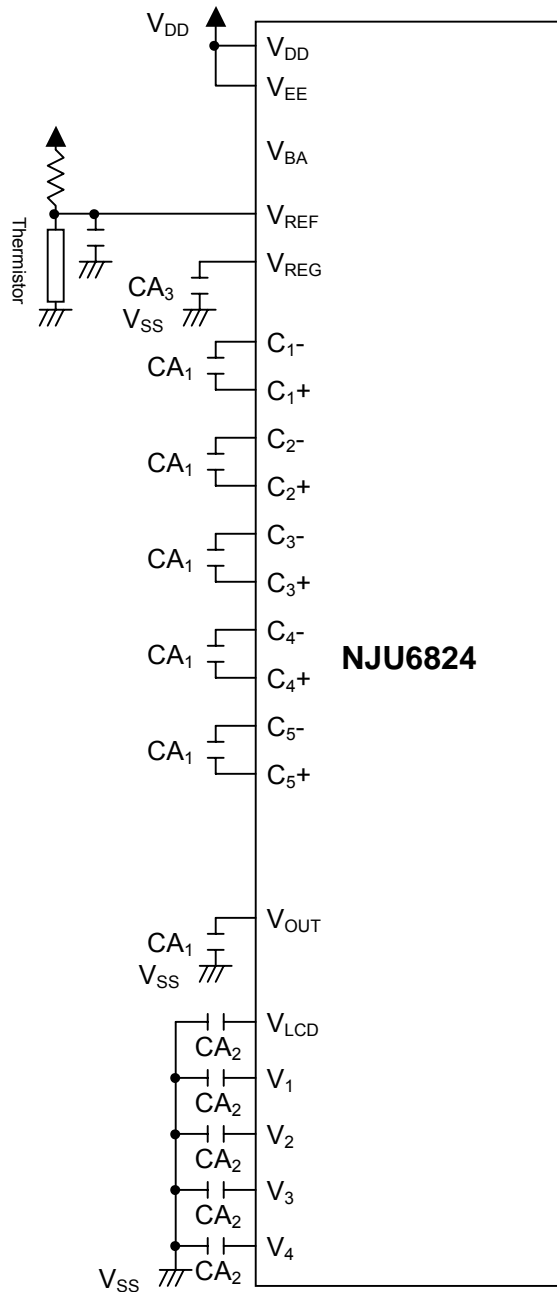

Fig 13

Reference value

CA ₁	1.0 to 4.7μF
CA ₂	1.0 to 2.2μF
CA ₃	0.1μF

Note) B grade capacitors are required.

Using internal power supply circuits
Without the voltage booster

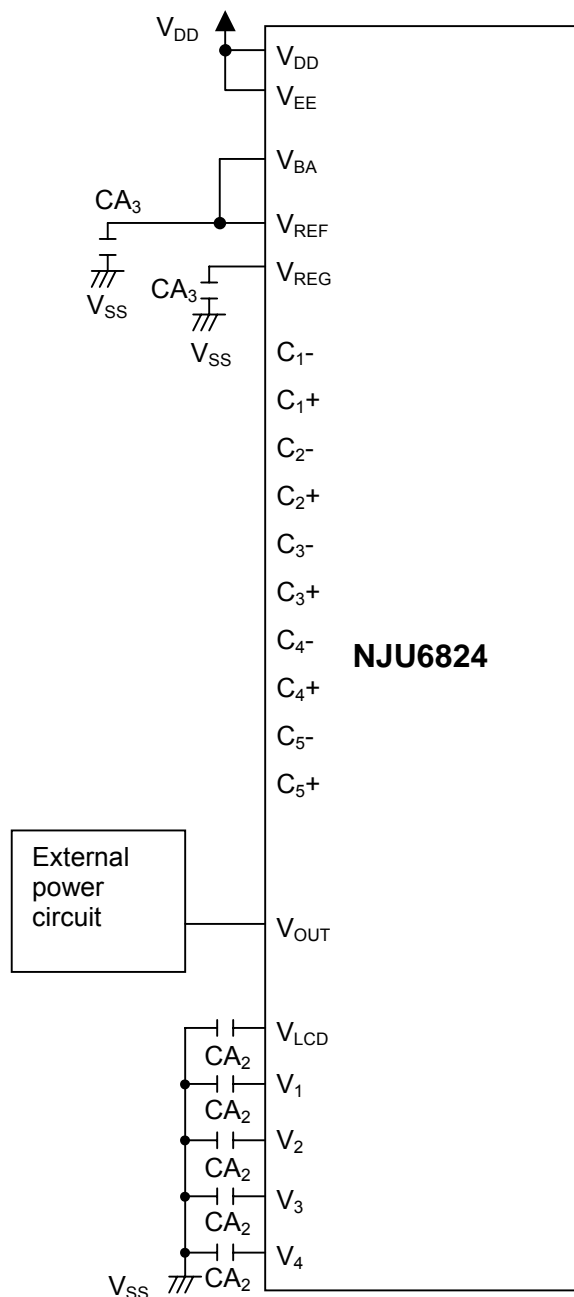

Fig 14

Reference value

CA ₁	1.0 to 4.7μF
CA ₂	1.0 to 2.2μF
CA ₃	0.1μF

Note) B grade capacitors are required.

(26) Partial display function

The partial display function is used to partially specify some parts of display area on LCD panels. By using this function, LCD modules can work in lower duty cycle ratio, lower LCD bias ratio, lower boost level and lower LCD driving voltage. It is usually used to display a time and calendar, and is also used to optimize the LSI condition in accordance with the display size. It can be programmed to select the duty cycle ratio (1/17, 1/25, 1/33, 1/41, 1/49, 1/57, 1/65, 1/73, 1/81, 1/89, 1/97, 1/105, 1/113, 1/121, 1/129, in DSE=0), the LCD bias ratio, the boost level and the EVR value by the instructions.

Partial display image

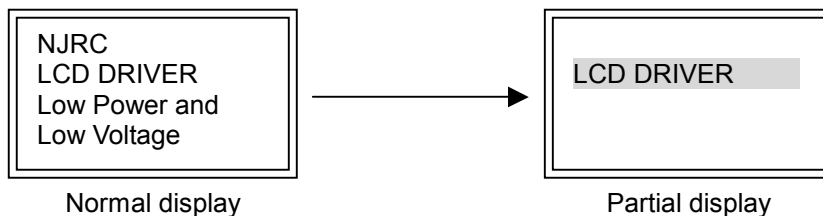

Partial display sequence

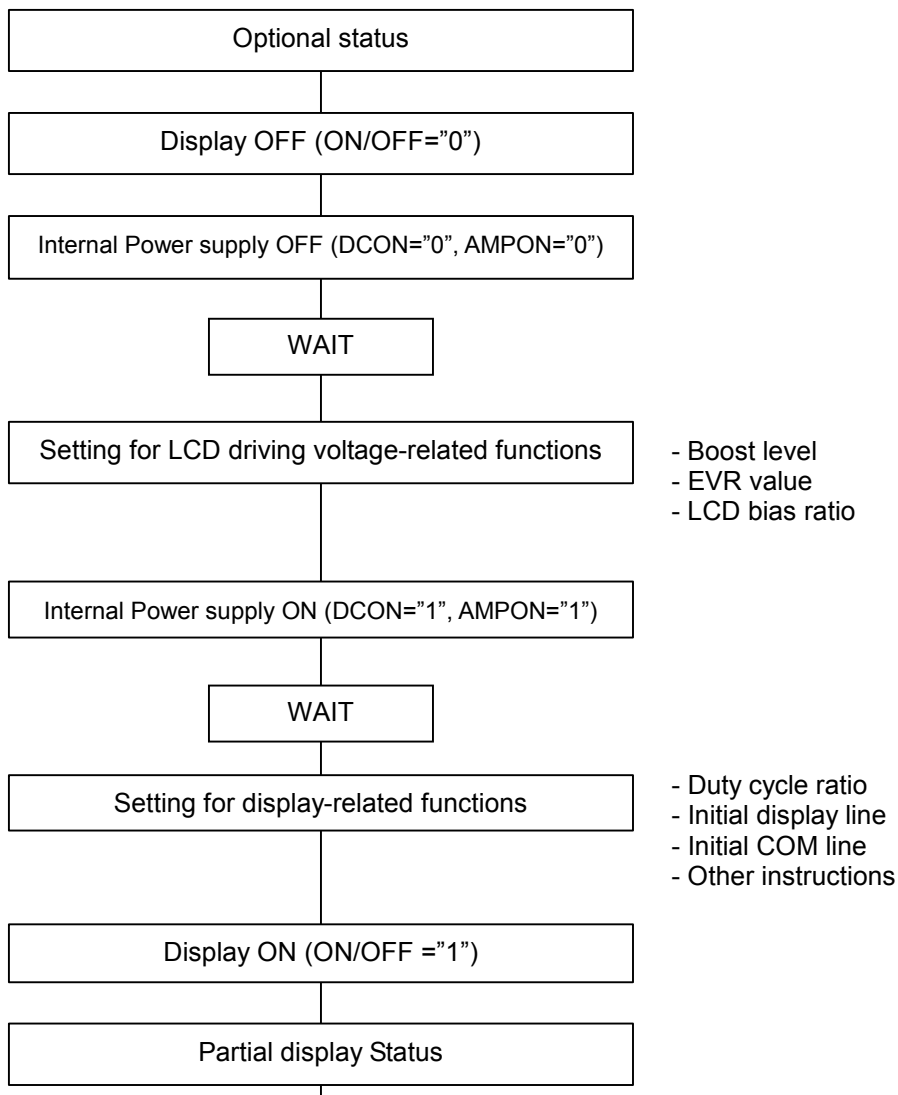

(27) Discharge circuit

Discharge circuit is used to discharge the electric charge of the capacitors on the V_1 to V_4 and V_{LCD} terminals. This circuit is activated by setting "0" to the "DIS" register of the "Discharge" instruction or by setting "RESb" terminal to "0" level. The "Discharge ON/OFF" instruction is usually required just after the internal power supply is turned off by setting "0" into the "DCON" and "AMPON" registers, or just after the external power supply is turned off. During the discharge operation, the internal or external power supply must not be turned on.

(28) Reset circuit

The reset circuit initializes the LSI into the following default status. It is activated by setting the RESb terminal to "0". The RESb terminal is usually required to connect to MPU reset terminal in order that the LSI can be initialized at the same timing of the MPU.

● Default status

1. DDRAM display data	:Undefined
2. column address	:(00) _H
3. row address	:(00) _H
4. Initial display line	:(0) _H (1st line)
5. Display ON/OFF	:OFF
6. Reverse display ON/OFF	:OFF (normal)
7. Duty cycle ratio	:1/129 duty(DSE=0)
8. N-line Inversion ON/OFF	:OFF
9. COM scan direction	:COM ₀ → COM ₁₂₇
10. Address direction of RAM	:(HV, XD, YD) = (0, 0, 0)
11. Read modify write	:OFF (AIM=0)
12. SWAP mode	:OFF (normal)
13. EVR value	:(0, 0, 0, 0, 0, 0, 0)
14. Internal power supply	:OFF
15. Display mode	:Gradation display mode
16. LCD bias ratio	:1/9 bias
17. Gradation Palette 0	:(0, 0, 0, 0, 0)
18. Gradation Palette 1	:(0, 0, 0, 1, 1)
19. Gradation Palette 2	:(0, 0, 1, 0, 1)
20. Gradation Palette 3	:(0, 0, 1, 1, 1)
21. Gradation Palette 4	:(0, 1, 0, 0, 1)
22. Gradation Palette 5	:(0, 1, 0, 1, 1)
23. Gradation Palette 6	:(0, 1, 1, 0, 1)
24. Gradation Palette 7	:(0, 1, 1, 1, 1)
25. Gradation Palette 8	:(1, 0, 0, 0, 1)
26. Gradation Palette 9	:(1, 0, 0, 1, 1)
27. Gradation Palette 10	:(1, 0, 1, 0, 1)
28. Gradation Palette 11	:(1, 0, 1, 1, 1)
29. Gradation Palette 12	:(1, 1, 0, 0, 1)
30. Gradation Palette 13	:(1, 1, 0, 1, 1)
31. Gradation Palette 14	:(1, 1, 1, 0, 1)
32. Gradation Palette 15	:(1, 1, 1, 1, 1)
33. Gradation mode control	:Variable gradation mode
34. Data bus length	:8-bit data bus length
35. Discharge circuit	:(DIS, DIS2)=(0,0)

(29) Power supply ON/OFF sequences

The following paragraphs describe power supply ON/OFF sequences, which are to protect the LSI from over current.

(29-1) Using an external power supply

- Power supply ON sequence

Logic voltage (V_{DD}) must be always input first, and next the LCD driving voltages (V_1 to V_4 and V_{LCD}) are turned on. In using the external V_{OUT} , the V_{DD} must be input first, next the reset operation must be performed, and finally the V_{OUT} can be input.

- Power supply OFF sequence

Either the reset operation, cutting off the V_1 to V_4 and V_{LCD} from the LSI by the RESb terminal or the "Power control" instruction must be performed first, and next the V_{DD} is turned off. It is recommended that a series-resistor between 50Ω and 100Ω is added on the V_{LCD} line (or V_{OUT} line in using only the external V_{OUT} voltage) in order to protect the LSI from the over current.

(29-2) Using the internal power supply circuits

- Power supply ON sequence

The V_{DD} must be input first, next the reset operation must be performed, and finally the V_1 to V_4 and V_{LCD} can be turned on by setting "1" to the "DCON" and "AMPON" registers of the "Power control" instruction.

- Power supply OFF sequence

Either the reset operation by the RESb terminal or the "Power control" instruction must be performed first, and next the input voltage for the voltage booster (V_{EE}) and the V_{DD} can be turned off. If the V_{EE} is supplied from different power sources for V_{DD} , the V_{EE} is turned off first, and next the V_{DD} is turned off.

(30) Referential instruction sequences

(30-1) Initialization in using the internal power supply circuits

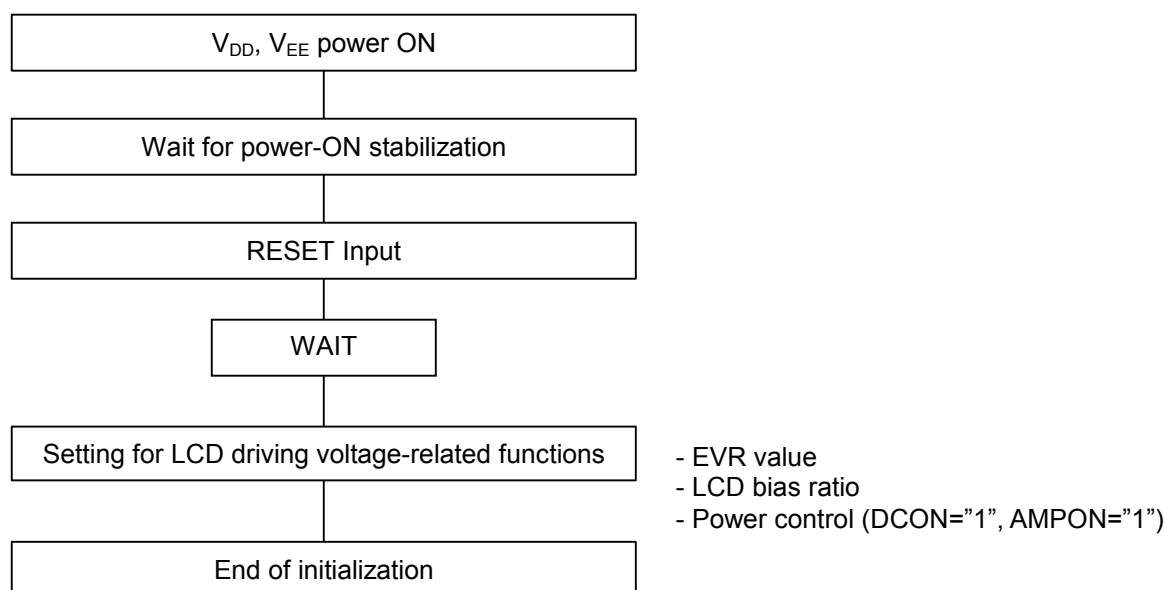

(30-2) Display data writing

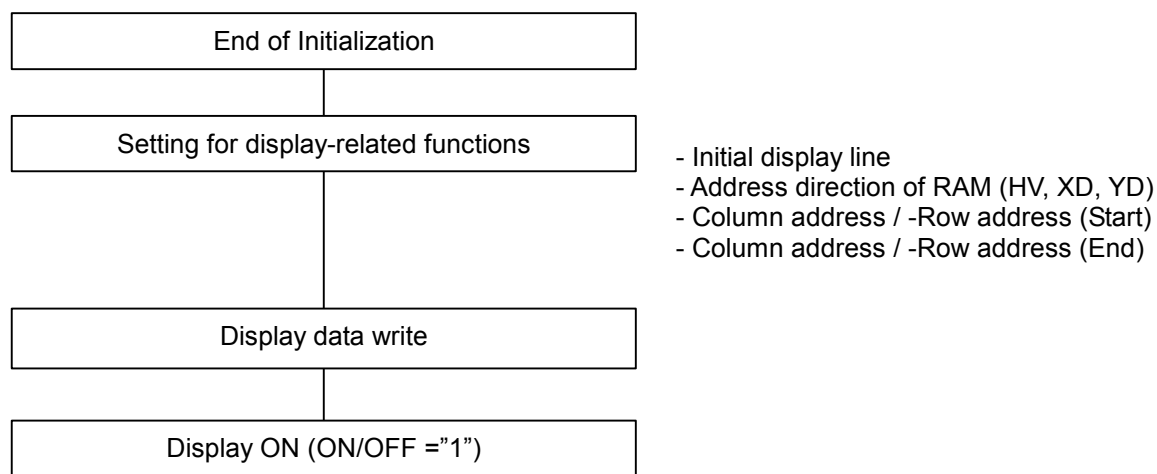

*: Before display data write / read operation, the address directions should be set first, then Column address set / Row address set of start point and end are set in order. (Display data write / read for whole display area or a portion requires the same procedure as above.)

To avoid incorrect data writing into registers by noise and so forth, the written data from registers should be checked after write operation.

(30-3) Power OFF

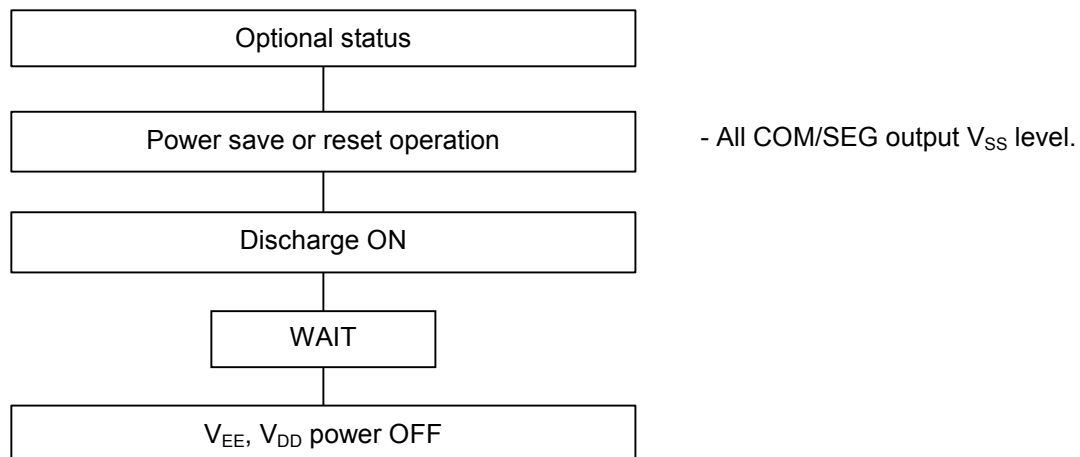

(31) Instruction table

Instruction Table (1)

Instructions	Code (80 series MPU I/F)							Code								Functions
	CSb	RS	RDb	WRb	RE ₂	RE ₁	RE ₀	D ₇	D ₆	D ₅	D ₄	D ₃	D ₂	D ₁	D ₀	
Display data write	0	0	1	0	0/1	0/1	0/1	Write Data								Write display data to DDRAM
Display data read	0	0	0	1	0/1	0/1	0/1	Read Data								Read display data from DDRAM
column address (Lower) [0 _H]	0	1	1	0	0	0	0	0	0	0	0	AX3	AX2	AX1	AX0	DDRAM column address
column address (Upper) [1 _H]	0	1	1	0	0	0	0	0	0	1	AX7	AX6	AX5	AX4	DDRAM column address	
row address (Lower) [2 _H]	0	1	1	0	0	0	0	0	0	1	0	AY3	AY2	AY1	AY0	DDRAM row address
row address (Upper) [3 _H]	0	1	1	0	0	0	0	0	0	1	1	*	AY6	AY5	AY4	DDRAM row address
Initial display line (Lower) [4 _H]	0	1	1	0	0	0	0	0	1	0	0	LA3	LA2	LA1	LA0	Row address for an initial COM line (Scan start line)
Initial display line (Upper) [5 _H]	0	1	1	0	0	0	0	0	1	0	1	*	LA6	LA5	LA4	Row address for an initial COM line (Scan start line)
N-line inversion (Lower) [6 _H]	0	1	1	0	0	0	0	0	1	1	0	N3	N2	N1	N0	The number of N-line inversion
N-line inversion (Upper) [7 _H]	0	1	1	0	0	0	0	0	1	1	1	*	N6	N5	N4	The number of N-line inversion
Display control (1) [8 _H]	0	1	1	0	0	0	0	1	0	0	0	SHIFT	MON	ALL ON	ON/ OFF	SHIFT: Common direction MON: Gradation or B/W display mode ALLON: All pixels ON/OFF ON/OFF: Display ON/OFF
Display control (2) [9 _H]	0	1	1	0	0	0	0	1	0	0	1	REV	NLIN	SWAP	*	REV: Reverse display ON/OFF NLIN: N-line inversion ON/OFF, SWAP: SWAP mode ON/OFF
Increment control [A _H]	0	1	1	0	0	0	0	1	0	1	0	AIM	HV	XD	YD	AIM: Read-modify-write ON/OFF HV: Increment / Decrement direction XD: Column Increment / Decrement set YD: Row Increment / Decrement set
Power control [B _H]	0	1	1	0	0	0	0	1	0	1	1	AMP ON	HALT	DC ON	ACL	AMPON: Voltage followers ON/OFF HALT: Power save ON/OFF DCON: Voltage booster ON/OFF ACL: Reset
Duty cycle ratio [C _H]	0	1	1	0	0	0	0	1	1	0	0	DS3	DS2	DS1	DS0	Sets LCD duty cycle ratio
Boost level [D _H]	0	1	1	0	0	0	0	1	1	0	1	*	VU2	VU1	VU0	Sets boost level
LCD bias ratio [E _H]	0	1	1	0	0	0	0	1	1	1	0	*	B2	B1	B0	Sets LCD bias ratio
RE register [F _H]	0	1	1	0	0/1	0/1	0/1	1	1	1	1	TST ₀	RE ₂	RE ₁	RE ₀	RE flag set

Note 1) * : Don't care.

Note 2) [N_H] : Address of instruction register

Note 3) The dual instructions including upper and lower bytes is enabled after either upper or lower bytes are set into the register. The only "EVR control" instruction is enabled after both of the upper and lower bytes are set.

Instruction Table (2)

Instructions	Code (80 series MPU I/F)							Code								Functions
	CSb	RS	RDb	WRb	RE ₂	RE ₁	RE ₀	D ₇	D ₆	D ₅	D ₄	D ₃	D ₂	D ₁	D ₀	
Gradation palette A0/A8 (Lower) [0 _H]	0	1	1	0	0	0	1	0	0	0	0	PA03/ PA83	PA02/ PA82	PA01/ PA81	PA00/ PA80	Sets palette values to gradation palette A0(PS=0)/A8(PS=1)
Gradation palette A0/A8 (Upper) [1 _H]	0	1	1	0	0	0	1	0	0	0	1	*	*	*	PA04/ PA84	Sets palette values to gradation palette A0(PS=0)/A8(PS=1)
Gradation palette A1/A9 (Lower) [2 _H]	0	1	1	0	0	0	1	0	0	1	0	PA13/ PA93	PA12/ PA92	PA11/ PA91	PA10/ PA90	Sets palette values to gradation palette A1(PS=0)/A9(PS=1)
Gradation palette A1/A9 (Upper) [3 _H]	0	1	1	0	0	0	1	0	0	1	1	*	*	*	PA14/ PA94	Sets palette values to gradation palette A1(PS=0)/A9(PS=1)
Gradation palette A2/A10 (Lower) [4 _H]	0	1	1	0	0	0	1	0	1	0	0	PA23/ PA103	PA22/ PA102	PA21/ PA101	PA20/ PA100	Sets palette values to gradation palette A2(PS=0)/A10(PS=1)
Gradation palette A2/A10 (Upper) [5 _H]	0	1	1	0	0	0	1	0	1	0	1	*	*	*	PA24/ PA104	Sets palette values to gradation palette A2(PS=0)/A10(PS=1)
Gradation palette A3/A11 (Lower) [6 _H]	0	1	1	0	0	0	1	0	1	1	0	PA33/ PA113	PA32/ PA112	PA31/ PA111	PA30/ PA110	Sets palette values to gradation palette A3(PS=0)/A11(PS=1)
Gradation palette A3/A11 (Upper) [7 _H]	0	1	1	0	0	0	1	0	1	1	1	*	*	*	PA34/ PA114	Sets palette values to gradation palette A3(PS=0)/A11(PS=1)
Gradation palette A4/A12 (Lower) [8 _H]	0	1	1	0	0	0	1	1	0	0	0	PA43/ PA123	PA42/ PA122	PA41/ PA121	PA40/ PA120	Sets palette values to gradation palette A4(PS=0)/A12(PS=1)
Gradation palette A4/A12 (Upper) [9 _H]	0	1	1	0	0	0	1	1	0	0	1	*	*	*	PA44/ PA124	Sets palette values to gradation palette A4(PS=0)/A12(PS=1)
Gradation palette A5/A13 (Lower) [A _H]	0	1	1	0	0	0	1	1	0	1	0	PA53/ PA133	PA52/ PA132	PA51/ PA131	PA50/ PA130	Sets palette values to gradation palette A5(PS=0)/A13(PS=1)
Gradation palette A5/A13 (Upper) [B _H]	0	1	1	0	0	0	1	1	0	1	1	*	*	*	PA54/ PA134	Sets palette values to gradation palette A5(PS=0)/A13(PS=1)
Gradation palette A6/A14 (Lower) [C _H]	0	1	1	0	0	0	1	1	1	0	0	PA63/ PA143	PA62/ PA142	PA61/ PA141	PA60/ PA140	Sets palette values to gradation palette A6(PS=0)/A14(PS=1)
Gradation palette A6/A14 (Upper) [D _H]	0	1	1	0	0	0	1	1	1	0	1	*	*	*	PA64/ PA144	Sets palette values to gradation palette A6(PS=0)/A14(PS=1)
RE register [F _H]	0	1	1	0	0/1	0/1	0/1	1	1	1	1	TST ₀	RE ₂	RE ₁	RE ₀	RE flag set

Note 1) * : Don't care.

Note 2) [N_H] : Address of Instruction register

Note 3) The dual instructions including upper and lower bytes is enabled after either upper or lower bytes are set into the register. The only "EVR control" instruction is enabled after both of the upper and lower bytes are set.

Instruction Table (3)

Instructions	Code (80 series MPU I/F)							Code								Functions
	CSb	RS	RDb	WRb	RE ₂	RE ₁	RE ₀	D ₇	D ₆	D ₅	D ₄	D ₃	D ₂	D ₁	D ₀	
Gradation palette A7/A15 (Lower) [0 _H]	0	1	1	0	0	1	0	0	0	0	0	PA73/ PA153	PA72/ PA152	PA71/ PA151	PA70/ PA150	Sets palette values to gradation palette A7(PS=0)/A15(PS=1)
Gradation palette A7/A15 (Upper) [1 _H]	0	1	1	0	0	1	0	0	0	0	1	*	*	*	PA74/ PA154	Sets palette values to gradation palette A7(PS=0)/A15(PS=1)
Gradation palette B0/B8 (Lower) [2 _H]	0	1	1	0	0	1	0	0	0	1	0	PB03/ PB83	PB02/ PB82	PB01/ PB81	PB00/ PB80	Sets palette values to gradation palette B0(PS=0)/B8(PS=1)
Gradation palette B0/B8 (Upper) [3 _H]	0	1	1	0	0	1	0	0	0	1	1	*	*	*	PB04/ PB84	Sets palette values to gradation palette B0(PS=0)/B8(PS=1)
Gradation palette B1/B9 (Lower) [4 _H]	0	1	1	0	0	1	0	0	1	0	0	PB13/ PB93	PB12/ PB92	PB11/ PB91	PB10/ PB90	Sets palette values to gradation palette B1(PS=0)/B9(PS=1)
Gradation palette B1/B9 (Upper) [5 _H]	0	1	1	0	0	1	0	0	1	0	1	*	*	*	PB14/ PB94	Sets palette values to gradation palette B1(PS=0)/B9(PS=1)
Gradation palette B2/B10 (Lower) [6 _H]	0	1	1	0	0	1	0	0	1	1	0	PB23/ PB103	PB22/ PB102	PB21/ PB101	PB20/ PB100	Sets palette values to gradation palette B2(PS=0)/B10(PS=1)
Gradation palette B2/B10 (Upper) [7 _H]	0	1	1	0	0	1	0	0	1	1	1	*	*	*	PB24/ PB104	Sets palette values to gradation palette B2(PS=0)/B10(PS=1)
Gradation palette B3/B11 (Lower) [8 _H]	0	1	1	0	0	1	0	1	0	0	0	PB33/ PB113	PB32/ PB112	PB31/ PB111	PB30/ PB110	Sets palette values to gradation palette B3(PS=0)/B11(PS=1)
Gradation palette B3/B11 (Upper) [9 _H]	0	1	1	0	0	1	0	1	0	0	1	*	*	*	PB34/ PB114	Sets palette values to gradation palette B3(PS=0)/B11(PS=1)
Gradation palette B4/B12 (Lower) [A _H]	0	1	1	0	0	1	0	1	0	1	0	PB43/ PB123	PB42/ PB122	PB41/ PB121	PB40/ PB120	Sets palette values to gradation palette B4(PS=0)/B12(PS=1)
Gradation palette B4/B12 (Upper) [B _H]	0	1	1	0	0	1	0	1	0	1	1	*	*	*	PB44/ PB124	Sets palette values to gradation palette B4(PS=0)/B12(PS=1)
Gradation palette B5/B13 (Lower) [C _H]	0	1	1	0	0	1	0	1	1	0	0	PB53/ PB133	PB52/ PB132	PB51/ PB131	PB50/ PB130	Sets palette values to gradation palette B5(PS=0)/B13(PS=1)
Gradation palette B5/B13 (Upper) [D _H]	0	1	1	0	0	1	0	1	1	0	1	*	*	*	PB54/ PB134	Sets palette values to gradation palette B5(PS=0)/B13(PS=1)
RE register [F _H]	0	1	1	0	0/1	0/1	0/1	1	1	1	1	TST ₀	RE ₂	RE ₁	RE ₀	RE flag set

Note 1) * : Don't care.

Note 2) [N_H] : Address of Instruction register

Note 3) The dual instructions including upper and lower bytes is enabled after either upper or lower bytes are set into the register. The only "EVR control" instruction is enabled after both of the upper and lower bytes are set.

Instruction Table (4)

Instructions	Code (80 series MPU I/F)							Code								Functions
	CSb	RS	RDb	WRb	RE ₂	RE ₁	RE ₀	D ₇	D ₆	D ₅	D ₄	D ₃	D ₂	D ₁	D ₀	
Gradation palette B6/B14 (Lower) [0 _H]	0	1	1	0	0	1	1	0	0	0	0	PB63/ PB143	PB62/ PB142	PB61/ PB141	PB60/ PB140	Sets palette values to gradation palette B6(PS=0)/B14(PS=1)
Gradation palette B6/B14 (Upper) [1 _H]	0	1	1	0	0	1	1	0	0	0	1	*	*	*	PB64/ PB144	Sets palette values to gradation palette B6(PS=0)/B14(PS=1)
Gradation palette B7/B15 (Lower) [2 _H]	0	1	1	0	0	1	1	0	0	1	0	PB73/ PB153	PB72/ PB152	PB71/ PB151	PB70/ PB150	Sets palette values to gradation palette B7(PS=0)/B15(PS=1)
Gradation palette B7/B15 (Upper) [3 _H]	0	1	1	0	0	1	1	0	0	1	1	*	*	*	PB74/ PB154	Sets palette values to gradation palette B7(PS=0)/B15(PS=1)
Gradation palette C0/C8 (Lower) [4 _H]	0	1	1	0	0	1	1	0	1	0	0	PC03/ PC83	PC02/ PC82	PC01/ PC81	PC00/ PC80	Sets palette values to gradation palette C0(PS=0)/C8(PS=1)
Gradation palette C0/C8 (Upper) [5 _H]	0	1	1	0	0	1	1	0	1	0	1	*	*	*	PC04/ PC84	Sets palette values to gradation palette C0(PS=0)/C8(PS=1)
Gradation palette C1/C9 (Lower) [6 _H]	0	1	1	0	0	1	1	0	1	1	0	PC13/ PC93	PC12/ PC92	PC11/ PC91	PC10/ PC90	Sets palette values to gradation palette C1(PS=0)/C9(PS=1)
Gradation palette C1/C9 (Upper) [7 _H]	0	1	1	0	0	1	1	0	1	1	1	*	*	*	PC14/ PC94	Sets palette values to gradation palette C1(PS=0)/C9(PS=1)
Gradation palette C2/C10 (Lower) [8 _H]	0	1	1	0	0	1	1	1	0	0	0	PC23/ PC103	PC22/ PC102	PC21/ PC101	PC20/ PC100	Sets palette values to gradation palette C2(PS=0)/C10(PS=1)
Gradation palette C2/C10 (Upper) [9 _H]	0	1	1	0	0	1	1	1	0	0	1	*	*	*	PC24/ PC104	Sets palette values to gradation palette C2(PS=0)/C10(PS=1)
Gradation palette C3/C11 (Lower) [A _H]	0	1	1	0	0	1	1	1	0	1	0	PC33/ PC113	PC32/ PC112	PC31/ PC111	PC30/ PC110	Sets palette values to gradation palette C3(PS=0)/C11(PS=1)
Gradation palette C3/C11 (Upper) [B _H]	0	1	1	0	0	1	1	1	0	1	1	*	*	*	PC34/ PC114	Sets palette values to gradation palette C3(PS=0)/C11(PS=1)
Gradation palette C4/C12 (Lower) [C _H]	0	1	1	0	0	1	1	1	1	0	0	PC43/ PC123	PC42/ PC122	PC41/ PC121	PC40/ PC120	Sets palette values to gradation palette C4(PS=0)/C12(PS=1)
Gradation palette C4/C12 (Upper) [D _H]	0	1	1	0	0	1	1	1	1	0	1	*	*	*	PC44/ PC124	Sets palette values to gradation palette C4(PS=0)/C12(PS=1)
RE register [F _H]	0	1	1	0	0/1	0/1	0/1	1	1	1	1	TST ₀	RE ₂	RE ₁	RE ₀	RE flag set

Note 1) * : Don't care.

Note 2) [N_H] : Address of Instruction register

Note 3) The dual instructions including upper and lower bytes is enabled after either upper or lower bytes are set into the register. The only "EVR control" instruction is enabled after both of the upper and lower bytes are set.

Instruction Table (5)

Instructions	Code (80 series MPU I/F)							Code								Functions
	CSb	RS	RDb	WRb	RE ₂	RE ₁	RE ₀	D ₇	D ₆	D ₅	D ₄	D ₃	D ₂	D ₁	D ₀	
Gradation palette C5/C13 (Lower) [0 _H]	0	1	1	0	1	0	0	0	0	0	0	PC53/ PC133	PC52/ PC132	PC51/ PC131	PC50/ PC130	Sets palette values to gradation palette C5(PS=0)/C13(PS=1)
Gradation palette C5/C13 (Upper) [1 _H]	0	1	1	0	1	0	0	0	0	0	1	*	*	*	PC54/ PC134	Sets palette values to gradation palette C5(PS=0)/C13(PS=1)
Gradation palette C6/C14 (Lower) [2 _H]	0	1	1	0	1	0	0	0	0	1	0	PC63/P C143	PC62/ PC142	PC61/ PC141	PC60/ PC140	Sets palette values to gradation palette C6(PS=0)/C14(PS=1)
Gradation palette C6/C14 (Upper) [3 _H]	0	1	1	0	1	0	0	0	0	1	1	*	*	*	PC64/ PC154	Sets palette values to gradation palette C6(PS=0)/C14(PS=1)
Gradation palette C7/C15 (Lower) [4 _H]	0	1	1	0	1	0	0	0	1	0	0	PC73/ PC153	PC72/ PC152	PC71/ PC151	PC70/ PC150	Sets palette values to gradation palette C7(PS=0)/C15(PS=1)
Gradation palette C7/C15 (Upper) [5 _H]	0	1	1	0	1	0	0	0	1	0	1	*	*	*	PC74/ PC154	Sets palette values to gradation palette C7(PS=0)/C15(PS=1)
Initial COM line [6 _H]	0	1	1	0	1	0	0	0	1	1	0	SC3	SC2	SC1	SC0	Sets scan-starting common driver
Display control Signal/ Duty Select [7 _H]	0	1	1	0	1	0	0	0	1	1	1	*	*	DSE	SON	SON : Display clock ON/OFF DSE : Duty-1 ON/OFF
Gradation mode control [8 _H]	0	1	1	0	1	0	0	1	0	0	0	PWM	C256	FDC1	FDC2	PWM : Variable/Fixed gradation mode C256 : 256-Color Mode ON/OFF FDC : Boost Clock
Data bus length [9 _H]	0	1	1	0	1	0	0	1	0	0	1	*	ABS	CKS	WLS	ABS : ABS mode ON/OFF CKS : Internal/external oscillation WLS : Display data Length
EVR control (Lower) [A _H]	0	1	1	0	1	0	0	1	0	1	0	DV3	DV2	DV1	DV0	Sets EVR level (Lower bit)
EVR control (Upper) [B _H]	0	1	1	0	1	0	0	1	0	1	1	*	DV6	DV5	DV4	Sets EVR level (Upper bit)
Frequency control [D _H]	0	1	1	0	1	0	0	1	1	0	1	*	RF2	RF1	RF0	Oscillation frequency
Discharge ON/OFF [E _H]	0	1	1	0	1	0	0	1	1	1	0	*	*	DIS2	DIS	Discharge the electric charge in capacitors on V ₁ to V ₄ and V _{LCD}
RE register [F _H]	0	1	1	0	0/1	0/1	0/1	1	1	1	1	TST ₀	RE ₂	RE ₁	RE ₀	RE flag
Instruction register address [C _H]	0	1	1	0	1	0	0	1	1	0	0	Reading address				Sets instruction register address
Instruction register read	0	1	0	1	0/1	0/1	0/1	*	*	*	*	Read Data				Read out instruction register data

Note 1) * : Don't care.

Note 2) [N_H] : Address of Instruction register

Note 3) The dual instructions including upper and lower bytes is enabled after either upper or lower bytes are set into the register. The only "EVR control" instruction is enabled after both of the upper and lower bytes are set.

Note 4) CKS=0: Internal oscillation mode (default)

CKS=1: External oscillation mode

Instruction Table (6)

Instructions	Code (80 series MPU I/F)						Code								Functions	
	CSb	RS	RDb	WRb	RE ₂	RE ₁	RE ₀	D ₇	D ₆	D ₅	D ₄	D ₃	D ₂	D ₁		D ₀
Window end column address (Lower) [0 _H]	0	1	1	0	1	0	1	0	0	0	0	EX3	EX2	EX1	EX0	Sets column address for end point
Window end column address (Upper) [1 _H]	0	1	1	0	1	0	1	0	0	0	1	EX7	EX6	EX5	EX4	Sets column address for end point
Window end row address (Lower) [2 _H]	0	1	1	0	1	0	1	0	0	1	0	EY3	EY2	EY1	EY0	Sets row address for end point
Window end row address (Upper) [3 _H]	0	1	1	0	1	0	1	0	0	1	1	*	EY6	EY5	EY4	Sets row address for end point
Initial reverse line (Lower) [4 _H]	0	1	1	0	1	0	1	0	1	0	0	LS3	LS2	LS1	LS0	Sets address for reverse line
Initial reverse line (Upper) [5 _H]	0	1	1	0	1	0	1	0	1	0	1	*	LS6	LS5	LS4	Sets address for reverse line
Last reverse line (Lower) [6 _H]	0	1	1	0	1	0	1	0	1	1	0	LE3	LE2	LE1	LE0	Sets address for reverse line
Last reverse line (Upper) [7 _H]	0	1	1	0	1	0	1	0	1	1	1	*	LE6	LE5	LE4	Sets address for reverse line
Reverse line display ON/OFF [8 _H]	0	1	1	0	1	0	1	1	0	0	0	*	*	BT	LREV	BT : Blink type setting LREV : Reverse line display ON/OFF
Gradation palette setting control / Icon SEG address [9 _H]	0	1	1	0	1	0	1	1	0	0	1	*	*	DMY	PS	PS : gradation setting DMY : Icon SEG address set
PWM control [A _H]	0	1	1	0	1	0	1	1	0	1	0	PWMS	PWMA	PWMB	PWMC	Sets PWM mode
RE register [F _H]	0	1	1	0	0/1	0/1	0/1	1	1	1	1	TST ₀	RE ₂	RE ₁	RE ₀	RE flag

Note 1) * : Don't care.

Note 2) [N_H] : Address of Instruction register

Note 3) The dual instructions including upper and lower bytes is enabled after either upper or lower bytes are set into the register. The only "EVR control" instruction is enabled after both of the upper and lower bytes are set.

(32) Instruction descriptions

This chapter provides detail descriptions and instruction registers. Nonexistent instruction codes must not be set into the LSI.

(32-1) Display data write

The "Display data write" instruction is used to write 8-bit display data into the DDRAM.

CSb	RS	RDb	WRb	RE ₂	RE ₁	RE ₀
0	0	1	0	0/1	0/1	0/1

D ₇	D ₆	D ₅	D ₄	D ₃	D ₂	D ₁	D ₀
Display data							

(32-2) Display data read

The "Display data read" instruction is used to read out 8-bit display data from the DDRAM, where the column address and row address must be specified beforehand by the "column address" and "row address" instructions. The dummy read is required just after the "column address" and "row address" instructions.

CSb	RS	RDb	WRb	RE ₂	RE ₁	RE ₀
0	0	0	1	0/1	0/1	0/1

D ₇	D ₆	D ₅	D ₄	D ₃	D ₂	D ₁	D ₀
Display data							

(32-3) Column address

The "column address" instruction is used to specify the column address for the display data's reading and writing operations. It requires dual bytes for lower 4-bit and upper 4-bit data. The instruction for the lower 4-bit data must be executed first, next the instruction for the upper 4-bit.

CSb	RS	RDb	WRb	RE ₂	RE ₁	RE ₀
0	1	1	0	0	0	0

D ₇	D ₆	D ₅	D ₄	D ₃	D ₂	D ₁	D ₀
0	0	0	0	AX ₃	AX ₂	AX ₁	AX ₀

CSb	RS	RDb	WRb	RE ₂	RE ₁	RE ₀
0	1	1	0	0	0	0

D ₇	D ₆	D ₅	D ₄	D ₃	D ₂	D ₁	D ₀
0	0	0	1	AX ₇	AX ₆	AX ₅	AX ₄

(32-4) Row address

The "row address" instruction is used to specify the row address for the display data read and write operations. It requires dual bytes for lower 4-bit and upper 3-bit data. The instruction for the lower 4-bit data must be executed first, next the instruction for upper 3-bit. The row address is specified in between 00_H and 7F_H. The setting for nonexistent row address between 80_H and FF_H is prohibited.

CSb	RS	RDb	WRb	RE ₂	RE ₁	RE ₀
0	1	1	0	0	0	0

D ₇	D ₆	D ₅	D ₄	D ₃	D ₂	D ₁	D ₀
0	0	1	0	AY ₃	AY ₂	AY ₁	AY ₀

CSb	RS	RDb	WRb	RE ₂	RE ₁	RE ₀
0	1	1	0	0	0	0

D ₇	D ₆	D ₅	D ₄	D ₃	D ₂	D ₁	D ₀
0	0	1	1	*	AY ₆	AY ₅	AY ₄

(32-5) Initial display line

The "Initial display line" instruction is used to specify the line address corresponding to the initial COM line. The initial COM line specified by the "Initial COM line" instruction and indicates the common driver that starts scanning data.

CSb	RS	RDb	WRb	RE ₂	RE ₁	RE ₀
0	1	1	0	0	0	0

D ₇	D ₆	D ₅	D ₄	D ₃	D ₂	D ₁	D ₀
0	1	0	0	LA ₃	LA ₂	LA ₁	LA ₀

CSb	RS	RDb	WRb	RE ₂	RE ₁	RE ₀
0	1	1	0	0	0	0

D ₇	D ₆	D ₅	D ₄	D ₃	D ₂	D ₁	D ₀
0	1	0	1	*	LA ₆	LA ₅	LA ₄

LA ₆	LA ₅	LA ₄	LA ₃	LA ₂	LA ₁	LA ₀	Line address
0	0	0	0	0	0	0	0
0	0	0	0	0	0	1	1
⋮							⋮
1	1	1	1	1	1	1	127

(32-6) N-line inversion

The "N-line inversion" instruction is used to control the alternate rates of the liquid crystal direction. It is programmed to select the N value between 2 and 128, and the FR signal toggles once every N lines by setting "1" into the "NLIN" register of the "Display control (2)" instruction. When the N-line inversion is disabled by setting "0" into the "NLIN" register, the FR signal toggles by the frame.

CSb	RS	RDb	WRb	RE ₂	RE ₁	RE ₀
0	1	1	0	0	0	0

D ₇	D ₆	D ₅	D ₄	D ₃	D ₂	D ₁	D ₀
0	1	1	0	N3	N2	N1	N0

CSb	RS	RDb	WRb	RE ₂	RE ₁	RE ₀
0	1	1	0	0	0	0

D ₇	D ₆	D ₅	D ₄	D ₃	D ₂	D ₁	D ₀
0	1	1	1	*	N6	N5	N4

N6	N5	N4	N3	N2	N1	N0	N value
0	0	0	0	0	0	0	Inhibited
0	0	0	0	0	0	1	2
⋮							⋮
0	1	0	0	0	0	0	128

● N-line Inversion Timing (1/129 duty cycle ratio)

N-line inversion OFF

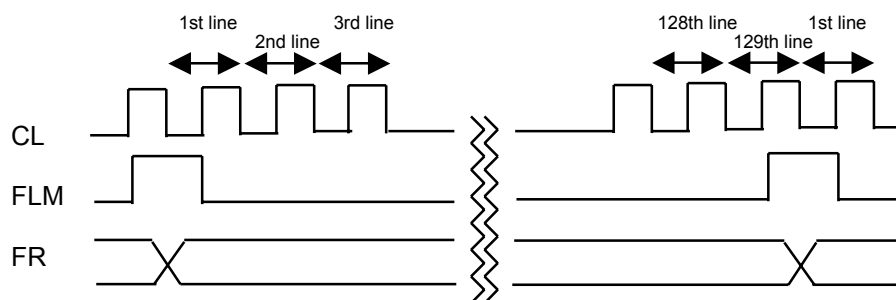

N-line inversion ON

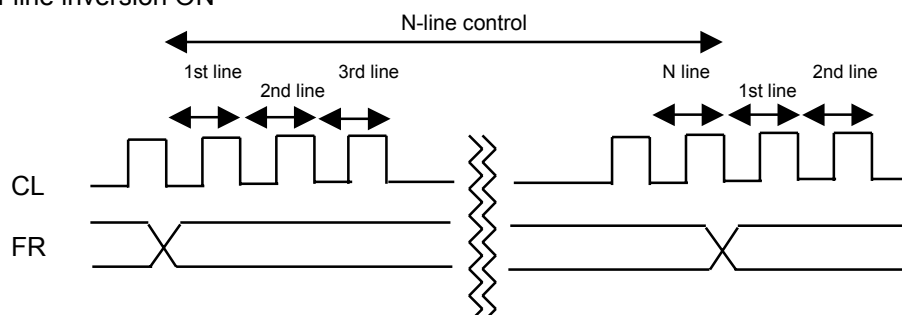

(32-7) Display control (1)

The "Display control (1)" instruction is used to control display conditions by setting the "Display ON/OFF", "All pixels ON/OFF", "Display mode" and "Common direction" registers.

CSb	RS	RDb	WRb	RE ₂	RE ₁	RE ₀
0	1	1	0	0	0	0

D ₇	D ₆	D ₅	D ₄	D ₃	D ₂	D ₁	D ₀
1	0	0	0	SHIFT	MON	ALLON	ON/OFF

● ON/OFF register

ON/OFF=0 : Display OFF (All COM/SEG output V_{ss} level.)
 ON/OFF=1 : Display ON

● All ON register

The "All pixels ON/OFF" register is used to turn on all pixels without changing display data of the DDRAM. The setting for the "All pixels ON/OFF" register has a priority over the "Reverse display ON/OFF" register.

ALLON=0 : Normal
 ALLON=1 : All pixels turn on.

● MON register

MON=0 : Gradation mode
 MON=1 : B&W mode

● SHIFT register

SHIFT=0 : COM₀ → COM₁₂₇
 SHIFT=1 : COM₁₂₇ → COM₀

(32-8) Display control (2)

The "Display control (2)" instruction is used to control display conditions by setting the "SWAP mode ON/OFF", "N-line inversion ON/OFF" and "Reverse display ON/OFF" registers.

CSb	RS	RDb	WRb	RE ₂	RE ₁	RE ₀
0	1	1	0	0	0	0

D ₇	D ₆	D ₅	D ₄	D ₃	D ₂	D ₁	D ₀
1	0	0	1	REV	NLIN	SWAP	*

- SWAP register

The "SWAP" register is used to reverse the arrangement of display data in the DDRAM.

SWAP=0 : SWAP mode OFF (Normal)
 SWAP=1 : SWAP mode ON

	SWAP="0"	SWAP="1"
Write data	D ₇ D ₆ D ₅ D ₄ D ₃ D ₂ D ₁ D ₀	D ₇ D ₆ D ₅ D ₄ D ₃ D ₂ D ₁ D ₀
	↓ ↓	↙ ↘
RAM data	D ₇ d ₆ d ₅ d ₄ d ₃ d ₂ d ₁ d ₀	d ₀ d ₁ d ₂ d ₃ d ₄ d ₅ d ₆ d ₇
	↓ ↓	↓ ↓
Read data	D ₇ D ₆ D ₅ D ₄ D ₃ D ₂ D ₁ D ₀	D ₇ D ₆ D ₅ D ₄ D ₃ D ₂ D ₁ D ₀

- NLIN register

The "NLIN" is used to enable or disable the N-line inversion.

NLIN=0 : N-line inversion OFF (The FR signal toggles by the frame.)
 NLIN=1 : N-line inversion ON (The FR signal toggles once every N frames.)

- REV register

The "REV" register is used to enable or disable the reverse display mode that reverses the polarity of display data without changing display data of the DDRAM.

REV=0 : Reverse display mode OFF
 REV=1 : Reverse display mode ON

REV	Display	DDRAM data → Display data	
0	Normal	0	0
		1	1
1	Reverse	0	1
		1	0

(32-9) Increment control

The "Increment control" instruction is used for the increment mode. In using the auto-increment mode, DDRAM address automatically increments (+1) whenever the DDRAM is accessed by the "Display data write" or "Display data read" instruction. Therefore, once "Display data write" or "Display data read" instruction is established, it is possible to continuously access to the DDRAM without the "column address" and "row address" instructions. The settings for the "AIM", "HV", "XD" and "YD" registers are listed in the following tables.

CSb	RS	RDb	WRb	RE ₂	RE ₁	RE ₀
0	1	1	0	0	0	0

D ₇	D ₆	D ₅	D ₄	D ₃	D ₂	D ₁	D ₀
1	0	1	0	AIM	HV	XD	YD

- AIM, HV, XD and YD registers

AIM	Increment mode	Note
0	Auto-increment for both of the display data read and write operations	1
1	Auto-increment for the display write operation (Read modify write)	2

Note 1) It is effective for usual operations accessing successive addresses.

Note 2) It is effective for the read-modify-write operation.

HV	XD	YD	Increment / Decrement mode / Scanning Direction
0	0	0	Column increment / Row increment / Horizontal direction
0	0	1	Column increment / Row decrement / Horizontal direction
0	1	0	Column decrement / Row increment / Horizontal direction
0	1	1	Column decrement / Row decrement / Horizontal direction
1	0	0	Column increment / Row increment / Vertical direction
1	0	1	Column increment / Row decrement / Vertical direction
1	1	0	Column decrement / Row increment / Vertical direction
1	1	1	Column decrement / Row decrement / Vertical direction

For the window area designation, the address directions of RAM (HV, XD, YD) must be set first, and Column address and Row of Start point must be set second, Column address and Row of Stop point must be set third, then RAM should be accessed. Low address must be set first and High address must be set second in all of addresses. The directions of HV, XD, YD should be check to keep the area in RAM.

(32-10) Power control

CSb	RS	RDb	WRb	RE ₂	RE ₁	RE ₀
0	1	1	0	0	0	0

D ₇	D ₆	D ₅	D ₄	D ₃	D ₂	D ₁	D ₀
1	0	1	1	AMPON	HALT	DCON	ACL

- ACL register

The "ACL" register is used to initialize the internal power supply circuits.

ACL=0 : Initialization OFF (Normal)
 ACL=1 : Initialization ON

When the data of the "ACL register" is read out by the "Instruction register read" instruction, the read-out data is "1" during the initialization and "0" after the initialization. This initialization is performed by using the signal produced by 2 clocks on the OSC₁. For this reason, the wait time for 2 clocks of the OSC₁ is necessary until next instruction.

- DCON register

The "DCON" register is used to enable or disable the voltage booster.

DCON=0 : Voltage booster OFF
 DCON=1 : Voltage booster ON

- HALT register

The "HALT" register is used to enable or disable the power save mode. It is possible to reduce operating current down to stand-by level. The internal status in the power save mode is listed below.

HALT=0 : Power save OFF (Normal)
 HALT=1 : Power save ON

Internal status in the power save mode

- The oscillation circuits and internal power supply circuits are halted.
- All segment and common drivers output V_{SS} level.
- The clock input into the OSC₁ is inhibited.
- The display data in the DDRAM is maintained.
- The operational modes before the power save mode are maintained.
- The V₁ to V₄ and V_{LCD} are in the high impedance.

As a power save ON sequence, the "Display OFF" must be executed first, next the "Power save ON" instruction, and then all common and segment drivers output the V_{SS} level. And as power save OFF sequence, the "Power save OFF" instruction is executed first, next the "Display ON" instruction. If the "Power save OFF" instruction is executed in the display ON status, unexpected pixels may instantly turn on.

- AMPON register

The "AMPON" register is used to enable or disable the voltage followers, voltage regulator and EVR.

AMPON=0 : The voltage followers, voltage regulator and the EVR OFF
 AMPON=1 : The voltage followers, voltage regulator and the EVR ON

(32-11) Duty cycle ratio

The "Duty cycle ratio" instruction is used to select LCD duty cycle ratio for the partial display function. The partial display function specifies some parts of display area on a LCD panel in the condition of lower duty cycle ratio, lower LCD bias ratio, lower boost level and lower LCD driving voltage. Therefore, it is possible to optimize the LSI's conditions with extremely low power consumption.

CSb	RS	RDb	WRb	RE ₂	RE ₁	RE ₀
0	1	1	0	0	0	0

D ₇	D ₆	D ₅	D ₄	D ₃	D ₂	D ₁	D ₀
1	1	0	0	DS ₃	DS ₂	DS ₁	DS ₀

DS ₃	DS ₂	DS ₁	DS ₀	Duty cycle ratio		Row way displays
				DSE=0	DSE=1	
0	0	0	0	1/129	1/128	128 commons
0	0	0	1	1/121	1/120	120 commons
0	0	1	0	1/113	1/112	112 commons
0	0	1	1	1/105	1/104	104 commons
0	1	0	0	1/97	1/96	96 commons
0	1	0	1	1/89	1/88	88 commons
0	1	1	0	1/81	1/80	80 commons
0	1	1	1	1/73	1/72	72 commons
1	0	0	0	1/65	1/64	64 commons
1	0	0	1	1/57	1/56	56 commons
1	0	1	0	1/49	1/48	48 commons
1	0	1	1	1/41	1/40	40 commons
1	1	0	0	1/33	1/32	32 commons
1	1	0	1	1/25	1/24	24 commons
1	1	1	0	1/17	1/16	16 commons
1	1	1	1	Inhibited		

The duty cycle ratio is controlled by the "DS₃ to DS₀" registers of the "Duty cycle ratio" instruction and the "DSE" register of the "Display Clock / Duty-1" instruction.

- DSE="0" : The number of commons + 1 (Duty cycle ratio in the default setting)
- DSE="1" : The number of commons (Duty-1)

When the "DSE" is "0", all common drivers output non-selective levels in period of last common. And the segment drivers output the same data for the last line as the data for previous line: For instance they output the same data for the 128th and 129th lines when the duty cycle ratio is set to 1/129. For the setting of the "DSE" register, see (32-17) "Display clock / Duty-1".

(32-12) Boost level

The "Boost level" is used to select the multiple of the voltage booster for the partial display function.

CSb	RS	RDb	WRb	RE ₂	RE ₁	RE ₀
0	1	1	0	0	0	0

D ₇	D ₆	D ₅	D ₄	D ₃	D ₂	D ₁	D ₀
1	1	0	1	*	VU ₂	VU ₁	VU ₀

VU ₂	VU ₁	VU ₀	Boost level
0	0	0	1-time (No boost)
0	0	1	2-time
0	1	0	3-time
0	1	1	4-time
1	0	0	5-time
1	0	1	6-time
1	1	0	Inhibited
1	1	1	Inhibited

(32-13) LCD bias ratio

The "LCD bias ratio" is used to select the LCD bias ratio for the partial display function.

CSb	RS	RDb	WRb	RE ₂	RE ₁	RE ₀
0	1	1	0	0	0	0

D ₇	D ₆	D ₅	D ₄	D ₃	D ₂	D ₁	D ₀
1	1	1	0	*	B ₂	B ₁	B ₀

B ₂	B ₁	B ₀	LCD bias ratio
0	0	0	1/9
0	0	1	1/8
0	1	0	1/7
0	1	1	1/6
1	0	0	1/5
1	0	1	1/10
1	1	0	1/11
1	1	1	1/12

(32-14) RE flag

The "RE flag" registers are used to determine the contents for the RE registers (RE₂, RE₁ and RE₀) and it is possible to access to the instruction registers.

The data in the "TST₀" register must be "0", and it is used maker tests only.

CSb	RS	RDb	WRb	RE ₂	RE ₁	RE ₀
0	1	1	0	0/1	0/1	0/1

D ₇	D ₆	D ₅	D ₄	D ₃	D ₂	D ₁	D ₀
1	1	1	1	TST ₀	RE ₂	RE ₁	RE ₀

(32-15) Gradation palette A, B and C

CSb	RS	RDb	WRb	RE ₂	RE ₁	RE ₀
0	1	1	0	0	0	1

D ₇	D ₆	D ₅	D ₄	D ₃	D ₂	D ₁	D ₀
0	0	0	0	PA ₀₃ / PA ₈₃	PA ₀₂ / PA ₈₂	PA ₀₁ / PA ₈₁	PA ₀₀ / PA ₈₀

CSb	RS	RDb	WRb	RE ₂	RE ₁	RE ₀
0	1	1	0	0	0	1

D ₇	D ₆	D ₅	D ₄	D ₃	D ₂	D ₁	D ₀
0	0	0	1	*	*	*	PA ₀₄ / PA ₈₄

CSb	RS	RDb	WRb	RE ₂	RE ₁	RE ₀
0	1	1	0	0	0	1

D ₇	D ₆	D ₅	D ₄	D ₃	D ₂	D ₁	D ₀
0	0	1	0	PA ₁₃ / PA ₉₃	PA ₁₂ / PA ₉₂	PA ₁₁ / PA ₉₁	PA ₁₀ / PA ₉₀

CSb	RS	RDb	WRb	RE ₂	RE ₁	RE ₀
0	1	1	0	0	0	1

D ₇	D ₆	D ₅	D ₄	D ₃	D ₂	D ₁	D ₀
0	0	1	1	*	*	*	PA ₁₄ / PA ₉₄

CSb	RS	RDb	WRb	RE ₂	RE ₁	RE ₀
0	1	1	0	0	0	1

D ₇	D ₆	D ₅	D ₄	D ₃	D ₂	D ₁	D ₀
0	1	0	0	PA ₂₃ / PA ₁₀₃	PA ₂₂ / PA ₁₀₂	PA ₂₁ / PA ₁₀₁	PA ₂₀ / PA ₁₀₀

CSb	RS	RDb	WRb	RE ₂	RE ₁	RE ₀
0	1	1	0	0	0	1

D ₇	D ₆	D ₅	D ₄	D ₃	D ₂	D ₁	D ₀
0	1	0	1	*	*	*	PA ₂₄ / PA ₁₀₄

CSb	RS	RDb	WRb	RE ₂	RE ₁	RE ₀
0	1	1	0	0	0	1

D ₇	D ₆	D ₅	D ₄	D ₃	D ₂	D ₁	D ₀
0	1	1	0	PA ₃₃ / PA ₁₁₃	PA ₃₂ / PA ₁₁₂	PA ₃₁ / PA ₁₁₁	PA ₃₀ / PA ₁₁₀

CSb	RS	RDb	WRb	RE ₂	RE ₁	RE ₀
0	1	1	0	0	0	1

D ₇	D ₆	D ₅	D ₄	D ₃	D ₂	D ₁	D ₀
0	1	1	1	*	*	*	PA ₃₄ / PA ₁₁₄

CSb	RS	RDb	WRb	RE ₂	RE ₁	RE ₀
0	1	1	0	0	0	1

D ₇	D ₆	D ₅	D ₄	D ₃	D ₂	D ₁	D ₀
1	0	0	0	PA ₄₃ / PA ₁₂₃	PA ₄₂ / PA ₁₂₂	PA ₄₁ / PA ₁₂₁	PA ₄₀ / PA ₁₂₀

CSb	RS	RDb	WRb	RE ₂	RE ₁	RE ₀
0	1	1	0	0	0	1

D ₇	D ₆	D ₅	D ₄	D ₃	D ₂	D ₁	D ₀
1	0	0	1	*	*	*	PA ₄₄ / PA ₁₂₄

CSb	RS	RDb	WRb	RE ₂	RE ₁	RE ₀
0	1	1	0	0	0	1

D ₇	D ₆	D ₅	D ₄	D ₃	D ₂	D ₁	D ₀
1	0	1	0	PA ₅₃ / PA ₁₃₃	PA ₅₂ / PA ₁₃₂	PA ₅₁ / PA ₁₃₁	PA ₅₀ / PA ₁₃₀

CSb	RS	RDb	WRb	RE ₂	RE ₁	RE ₀
0	1	1	0	0	0	1

D ₇	D ₆	D ₅	D ₄	D ₃	D ₂	D ₁	D ₀
1	0	1	1	*	*	*	PA ₅₄ / PA ₁₃₄

CSb	RS	RDb	WRb	RE ₂	RE ₁	RE ₀
0	1	1	0	0	0	1

D ₇	D ₆	D ₅	D ₄	D ₃	D ₂	D ₁	D ₀
1	1	0	0	PA ₆₃ / PA ₁₄₃	PA ₆₂ / PA ₁₄₂	PA ₆₁ / PA ₁₄₁	PA ₆₀ / PA ₁₄₀

CSb	RS	RDb	WRb	RE ₂	RE ₁	RE ₀
0	1	1	0	0	0	1

D ₇	D ₆	D ₅	D ₄	D ₃	D ₂	D ₁	D ₀
1	1	0	1	*	*	*	PA ₆₄ / PA ₁₄₄

CSb	RS	RDb	WRb	RE ₂	RE ₁	RE ₀
0	1	1	0	0	1	0

D ₇	D ₆	D ₅	D ₄	D ₃	D ₂	D ₁	D ₀
0	0	0	0	PA ₇₃ / PA ₁₅₃	PA ₇₂ / PA ₁₅₂	PA ₇₁ / PA ₁₅₁	PA ₇₀ / PA ₁₅₀

CSb	RS	RDb	WRb	RE ₂	RE ₁	RE ₀
0	1	1	0	0	1	0

D ₇	D ₆	D ₅	D ₄	D ₃	D ₂	D ₁	D ₀
0	0	0	1	*	*	*	PA ₇₄ / PA ₁₅₄

CSb	RS	RDb	WRb	RE ₂	RE ₁	RE ₀
0	1	1	0	0	1	0

D ₇	D ₆	D ₅	D ₄	D ₃	D ₂	D ₁	D ₀
0	0	1	0	PB ₀₃ / PB ₈₃	PB ₀₂ / PB ₈₂	PB ₀₁ / PB ₈₁	PB ₀₀ / PB ₈₀

CSb	RS	RDb	WRb	RE ₂	RE ₁	RE ₀
0	1	1	0	0	1	0

D ₇	D ₆	D ₅	D ₄	D ₃	D ₂	D ₁	D ₀
0	0	1	1	*	*	*	PB ₀₄ / PB ₈₄

CSb	RS	RDb	WRb	RE ₂	RE ₁	RE ₀
0	1	1	0	0	1	0

D ₇	D ₆	D ₅	D ₄	D ₃	D ₂	D ₁	D ₀
0	1	0	0	PB ₁₃ / PB ₉₃	PB ₁₂ / PB ₉₂	PB ₁₁ / PB ₉₁	PB ₁₀ / PB ₉₀

CSb	RS	RDb	WRb	RE ₂	RE ₁	RE ₀
0	1	1	0	0	1	0

D ₇	D ₆	D ₅	D ₄	D ₃	D ₂	D ₁	D ₀
0	1	0	1	*	*	*	PB ₁₄ / PB ₉₄

CSb	RS	RDb	WRb	RE ₂	RE ₁	RE ₀
0	1	1	0	0	1	0

D ₇	D ₆	D ₅	D ₄	D ₃	D ₂	D ₁	D ₀
0	1	1	0	PB ₂₃ / PB ₁₀₃	PB ₂₂ / PB ₁₀₂	PB ₂₁ / PB ₁₀₁	PB ₂₀ / PB ₁₀₀

CSb	RS	RDb	WRb	RE ₂	RE ₁	RE ₀
0	1	1	0	0	1	0

D ₇	D ₆	D ₅	D ₄	D ₃	D ₂	D ₁	D ₀
0	1	1	1	*	*	*	PB ₂₄ / PB ₁₀₄

CSb	RS	RDb	WRb	RE ₂	RE ₁	RE ₀
0	1	1	0	0	1	0

D ₇	D ₆	D ₅	D ₄	D ₃	D ₂	D ₁	D ₀
1	0	0	0	PB ₃₃ / PB ₁₁₃	PB ₃₂ / PB ₁₁₂	PB ₃₁ / PB ₁₁₁	PB ₃₀ / PB ₁₁₀

CSb	RS	RDb	WRb	RE ₂	RE ₁	RE ₀
0	1	1	0	0	1	0

D ₇	D ₆	D ₅	D ₄	D ₃	D ₂	D ₁	D ₀
1	0	0	1	*	*	*	PB ₃₄ / PB ₁₁₄

CSb	RS	RDb	WRb	RE ₂	RE ₁	RE ₀
0	1	1	0	0	1	0

D ₇	D ₆	D ₅	D ₄	D ₃	D ₂	D ₁	D ₀
1	0	1	0	PB ₄₃ / PB ₁₂₃	PB ₄₂ / PB ₁₂₂	PB ₄₁ / PB ₁₂₁	PB ₄₀ / PB ₁₂₀

CSb	RS	RDb	WRb	RE ₂	RE ₁	RE ₀
0	1	1	0	0	1	0

D ₇	D ₆	D ₅	D ₄	D ₃	D ₂	D ₁	D ₀
1	0	1	1	*	*	*	PB ₄₄ / PB ₁₂₄

CSb	RS	RDb	WRb	RE ₂	RE ₁	RE ₀
0	1	1	0	0	1	0

D ₇	D ₆	D ₅	D ₄	D ₃	D ₂	D ₁	D ₀
1	1	0	0	PB ₅₃ / PB ₁₃₃	PB ₅₂ / PB ₁₃₂	PB ₅₁ / PB ₁₃₁	PB ₅₀ / PB ₁₃₀

CSb	RS	RDb	WRb	RE ₂	RE ₁	RE ₀
0	1	1	0	0	1	0

D ₇	D ₆	D ₅	D ₄	D ₃	D ₂	D ₁	D ₀
1	1	0	1	*	*	*	PB ₅₄ / PB ₁₃₄

CSb	RS	RDb	WRb	RE ₂	RE ₁	RE ₀
0	1	1	0	0	1	1

D ₇	D ₆	D ₅	D ₄	D ₃	D ₂	D ₁	D ₀
0	0	0	0	PB ₆₃ / PB ₁₄₃	PB ₆₂ / PB ₁₄₂	PB ₆₁ / PB ₁₄₁	PB ₆₀ / PB ₁₄₀

CSb	RS	RDb	WRb	RE ₂	RE ₁	RE ₀
0	1	1	0	0	1	1

D ₇	D ₆	D ₅	D ₄	D ₃	D ₂	D ₁	D ₀
0	0	0	1	*	*	*	PB ₆₄ / PB ₁₄₄

CSb	RS	RDb	WRb	RE ₂	RE ₁	RE ₀
0	1	1	0	0	1	1

D ₇	D ₆	D ₅	D ₄	D ₃	D ₂	D ₁	D ₀
0	0	1	0	PB ₇₃ / PB ₁₅₃	PB ₇₂ / PB ₁₅₂	PB ₇₁ / PB ₁₅₁	PB ₇₀ / PB ₁₅₀

CSb	RS	RDb	WRb	RE ₂	RE ₁	RE ₀
0	1	1	0	0	1	1

D ₇	D ₆	D ₅	D ₄	D ₃	D ₂	D ₁	D ₀
0	0	1	1	*	*	*	PB ₇₄ / PB ₁₅₄

CSb	RS	RDb	WRb	RE ₂	RE ₁	RE ₀
0	1	1	0	0	1	1

D ₇	D ₆	D ₅	D ₄	D ₃	D ₂	D ₁	D ₀
0	1	0	0	PC ₀₃ / PC ₈₃	PC ₀₂ / PC ₈₂	PC ₀₁ / PC ₈₁	PC ₀₀ / PC ₈₀

CSb	RS	RDb	WRb	RE ₂	RE ₁	RE ₀
0	1	1	0	0	1	1

D ₇	D ₆	D ₅	D ₄	D ₃	D ₂	D ₁	D ₀
0	1	0	1	*	*	*	PC ₀₄ / PC ₈₄

CSb	RS	RDb	WRb	RE ₂	RE ₁	RE ₀
0	1	1	0	0	1	1

D ₇	D ₆	D ₅	D ₄	D ₃	D ₂	D ₁	D ₀
0	1	1	0	PC ₁₃ / PC ₉₃	PC ₁₂ / PC ₉₂	PC ₁₁ / PC ₉₁	PC ₁₀ / PC ₉₀

CSb	RS	RDb	WRb	RE ₂	RE ₁	RE ₀
0	1	1	0	0	1	1

D ₇	D ₆	D ₅	D ₄	D ₃	D ₂	D ₁	D ₀
0	1	1	1	*	*	*	PC ₁₄ / PC ₉₄

CSb	RS	RDb	WRb	RE ₂	RE ₁	RE ₀
0	1	1	0	0	1	1

D ₇	D ₆	D ₅	D ₄	D ₃	D ₂	D ₁	D ₀
1	0	0	0	PC ₂₃ / PC ₁₀₃	PC ₂₂ / PC ₁₀₂	PC ₂₁ / PC ₁₀₁	PC ₂₀ / PC ₁₀₀

CSb	RS	RDb	WRb	RE ₂	RE ₁	RE ₀
0	1	1	0	0	1	1

D ₇	D ₆	D ₅	D ₄	D ₃	D ₂	D ₁	D ₀
1	0	0	1	*	*	*	PC ₂₄ / PC ₁₀₄

CSb	RS	RDb	WRb	RE ₂	RE ₁	RE ₀
0	1	1	0	0	1	1

D ₇	D ₆	D ₅	D ₄	D ₃	D ₂	D ₁	D ₀
1	0	1	0	PC ₃₃ / PC ₁₁₃	PC ₃₂ / PC ₁₁₂	PC ₃₁ / PC ₁₁₁	PC ₃₀ / PC ₁₁₀

CSb	RS	RDb	WRb	RE ₂	RE ₁	RE ₀
0	1	1	0	0	1	1

D ₇	D ₆	D ₅	D ₄	D ₃	D ₂	D ₁	D ₀
1	0	1	1	*	*	*	PC ₃₄ / PC ₁₁₄

CSb	RS	RDb	WRb	RE ₂	RE ₁	RE ₀
0	1	1	0	0	1	1

D ₇	D ₆	D ₅	D ₄	D ₃	D ₂	D ₁	D ₀
1	1	0	0	PC ₄₃ / PC ₁₂₃	PC ₄₂ / PC ₁₂₂	PC ₄₁ / PC ₁₂₁	PC ₄₀ / PC ₁₂₀

CSb	RS	RDb	WRb	RE ₂	RE ₁	RE ₀
0	1	1	0	0	1	1

D ₇	D ₆	D ₅	D ₄	D ₃	D ₂	D ₁	D ₀
1	1	0	1	*	*	*	PC ₄₄ / PC ₁₂₄

CSb	RS	RDb	WRb	RE ₂	RE ₁	RE ₀
0	1	1	0	1	0	0

D ₇	D ₆	D ₅	D ₄	D ₃	D ₂	D ₁	D ₀
0	0	0	0	PC ₅₃ / PC ₁₃₃	PC ₅₂ / PC ₁₃₂	PC ₅₁ / PC ₁₃₁	PC ₅₀ / PC ₁₃₀

CSb	RS	RDb	WRb	RE ₂	RE ₁	RE ₀
0	1	1	0	1	0	0

D ₇	D ₆	D ₅	D ₄	D ₃	D ₂	D ₁	D ₀
0	0	0	1	*	*	*	PC ₅₄ / PC ₁₃₄

CSb	RS	RDb	WRb	RE ₂	RE ₁	RE ₀
0	1	1	0	1	0	0

D ₇	D ₆	D ₅	D ₄	D ₃	D ₂	D ₁	D ₀
0	0	1	0	PC ₆₃ / PC ₁₄₃	PC ₆₂ / PC ₁₄₂	PC ₆₁ / PC ₁₄₁	PC ₆₀ / PC ₁₄₀

CSb	RS	RDb	WRb	RE ₂	RE ₁	RE ₀
0	1	1	0	1	0	0

D ₇	D ₆	D ₅	D ₄	D ₃	D ₂	D ₁	D ₀
0	0	1	1	*	*	*	PC ₆₄ / PC ₁₄₄

CSb	RS	RDb	WRb	RE ₂	RE ₁	RE ₀
0	1	1	0	1	0	0

D ₇	D ₆	D ₅	D ₄	D ₃	D ₂	D ₁	D ₀
0	1	0	0	PC ₇₃ / PC ₁₅₃	PC ₇₂ / PC ₁₅₂	PC ₇₁ / PC ₁₅₁	PC ₇₀ / PC ₁₅₀

CSb	RS	RDb	WRb	RE ₂	RE ₁	RE ₀
0	1	1	0	1	0	0

D ₇	D ₆	D ₅	D ₄	D ₃	D ₂	D ₁	D ₀
0	1	0	1	*	*	*	PC ₇₄ / PC ₁₅₄

Gradation Palette Table (Variable gradation mode, PWM="0" and MON="0")

(Palette Aj, Palette Bj, Palette Cj, (j=0 to 15))

Palette Value	Gradation Level	Note	Palette Value	Gradation Level	Note
0 0 0 0 0	0/31	Gradation Palette 0 Initial Value	1 0 0 0 0	16/31	
0 0 0 0 1	1/31		1 0 0 0 1	17/31	Gradation Palette 8 Initial Value
0 0 0 1 0	2/31		1 0 0 1 0	18/31	
0 0 0 1 1	3/31	Gradation Palette 1 Initial Value	1 0 0 1 1	19/31	Gradation Palette 9 Initial Value
0 0 1 0 0	4/31		1 0 1 0 0	20/31	
0 0 1 0 1	5/31	Gradation Palette 2 Initial Value	1 0 1 0 1	21/31	Gradation Palette 10 Initial Value
0 0 1 1 0	6/31		1 0 1 1 0	22/31	
0 0 1 1 1	7/31	Gradation Palette 3 Initial Value	1 0 1 1 1	23/31	Gradation Palette 11 Initial Value
0 1 0 0 0	8/31		1 1 0 0 0	24/31	
0 1 0 0 1	9/31	Gradation Palette 4 Initial Value	1 1 0 0 1	25/31	Gradation Palette 12 Initial Value
0 1 0 1 0	10/31		1 1 0 1 0	26/31	
0 1 0 1 1	11/31	Gradation Palette 5 Initial Value	1 1 0 1 1	27/31	Gradation Palette 13 Initial Value
0 1 1 0 0	12/31		1 1 1 0 0	28/31	
0 1 1 0 1	13/31	Gradation Palette 6 Initial Value	1 1 1 0 1	29/31	Gradation Palette 14 Initial Value
0 1 1 1 0	14/31		1 1 1 1 0	30/31	
0 1 1 1 1	15/31	Gradation Palette 7 Initial Value	1 1 1 1 1	31/31	Gradation Palette 15 Initial Value

(32-16) Initial COM line

The "Initial COM line" instruction is used to specify the common driver that starts scanning the display data. The line address, corresponding to the initial COM line, is specified by the "Initial display line" instruction.

CSb	RS	RDb	WRb	RE ₂	RE ₁	RE ₀
0	1	1	0	1	0	0

D ₇	D ₆	D ₅	D ₄	D ₃	D ₂	D ₁	D ₀
0	1	1	0	SC ₃	SC ₂	SC ₁	SC ₀

SC3	SC2	SC1	SC0	Initial COM line (SHIFT=0)	Initial COM line (SHIFT=1)
0	0	0	0	COM ₀	COM ₁₂₇
0	0	0	1	COM ₄	COM ₁₂₃
0	0	1	0	COM ₈	COM ₁₁₉
0	0	1	1	COM ₁₆	COM ₁₁₁
0	1	0	0	COM ₂₄	COM ₁₀₃
0	1	0	1	COM ₃₂	COM ₉₅
0	1	1	0	COM ₄₀	COM ₈₇
0	1	1	1	COM ₄₈	COM ₇₉
1	0	0	0	COM ₅₆	COM ₇₁
1	0	0	1	COM ₆₄	COM ₆₃
1	0	1	0	COM ₇₂	COM ₅₅
1	0	1	1	COM ₈₀	COM ₄₇
1	1	0	0	COM ₈₈	COM ₃₉
1	1	0	1	COM ₉₆	COM ₃₁
1	1	1	0	COM ₁₀₄	COM ₂₃
1	1	1	1	COM ₁₁₂	COM ₁₅

SHIFT=0: Positive scan direction
 SHIFT=1: Negative scan direction

(for instance, COM₀ → COM₁₂₇)
 (for instance, COM₁₂₇ → COM₀)

(32-17) Display clock / Duty-1

The "Display clock / Duty-1" instruction is used to enable or disable the display clocks (CL, FLM, FR, and CLK), and to control ON/OFF of the "Duty-1". For more detail about the "Duty-1", see (32-11) "Duty cycle ratio".

CSb	RS	RDb	WRb	RE ₂	RE ₁	RE ₀
0	1	1	0	1	0	0

D ₇	D ₆	D ₅	D ₄	D ₃	D ₂	D ₁	D ₀
0	1	1	1	*	*	DSE	SON

SON=0: CL, FLM, FR, and CLK outputs level "0".
 SON=1: CL, FLM, FR, and CLK outputs are active.

DSE=0: Duty -1 OFF
 DSE=1: Duty -1 ON

(32-18) Gradation mode control

The "Gradation mode control" is used to select display mode as follows.

CSb	RS	RDb	WRb	RE ₂	RE ₁	RE ₀
0	1	1	0	1	0	0

D ₇	D ₆	D ₅	D ₄	D ₃	D ₂	D ₁	D ₀
1	0	0	0	PWM	C256	FDC1	FDC2

- PWM register

- PWM=0: Variable gradation mode
(Variable 16-gradation levels out of 32-gradation level of the gradation palette)
- PWM=1: Fixed gradation mode
(Fixed 8-gradation levels)

- C256 register

- C256=0 256-color mode OFF (4,096-color in the default setting)
- C256=1 256-color mode ON

- FDC1 and FDC2 register

FDC1	FDC2	Boost Clock
0	0	×1
0	1	×2
1	0	×4
1	1	×1/2

(32-19)Data bus length

The "Data bus length" instruction is used to select the 8- or 16- bit data bus length and determine the internal or external oscillation. In the 16-bit data bus mode, instruction data must be 16-bit (D₁₅ to D₀) as well as display data. However, for the access to the instruction registers, the lower 8-bit data (D₇ to D₀) of the 16-bit data is valid. For the access to the DDRAM, all of the 16-bit data (D₁₅ to D₀) is valid.

CSb	RS	RDb	WRb	RE ₂	RE ₁	RE ₀
0	1	1	0	1	0	0

D ₇	D ₆	D ₅	D ₄	D ₃	D ₂	D ₁	D ₀
1	0	0	1	*	ABS	CKS	WLS

- ABS register

ABS=0: ABS mode OFF (normal)
 ABS=1: ABS mode ON

- WLS register

WLS=0: 8-bit data bus length
 WLS =1: 16-bit data bus length

- CKS register

CKS =0: Internal oscillation
 (The OSC₁ terminal must be fixed "1" or "0".)
 CKS =1: External oscillation
 (By the external clock into the OSC₁ or external resistor between the OSC₁ and OSC₂. OSC₂ should be open when clock is inputted from OSC₁.)

(32-20)EVR control

The "EVR control" instruction is used to fine-tune the LCD driving voltage (V_{LCD}) so that it is possible to optimize the contrast level for a LCD panel.

This instruction must be programmed by upper 3-bit data first, next lower 4-bit data. And it becomes enabled when the lower 4-bit data is programmed, so that it can prevent unexpected high voltage for the VLCD from being generated.

CSb	RS	RDb	WRb	RE ₂	RE ₁	RE ₀
0	1	1	0	1	0	0

D ₇	D ₆	D ₅	D ₄	D ₃	D ₂	D ₁	D ₀
1	0	1	0	DV ₃	DV ₂	DV ₁	DV ₀

CSb	RS	RDb	WRb	RE ₂	RE ₁	RE ₀
0	1	1	0	1	0	0

D ₇	D ₆	D ₅	D ₄	D ₃	D ₂	D ₁	D ₀
1	0	1	1	*	DV ₆	DV ₅	DV ₄

DV ₆	DV ₅	DV ₄	DV ₃	DV ₂	DV ₁	DV ₀	V_{LCD}
0	0	0	0	0	0	0	Low
0	0	0	0	0	0	1	:
			:				:
			:				:
1	1	1	1	1	1	1	High

The formula of the V_{LCD} is shown below.

$$V_{LCD} [V] = 0.5 \times V_{REG} + M (V_{REG} - 0.5 \times V_{REG}) / 127$$

$$V_{BA} = V_{EE} \times 0.9$$

$$V_{REG} = V_{REF} \times N$$

- V_{BA} : Output voltage of the reference voltage generator
- V_{REF} : Input voltage of the voltage regulator
- V_{REG} : Output voltage of the voltage regulator
- N : Register value for the voltage booster
- M : Register value for the EVR

(32-21) Frequency control

The "Frequency control" instruction is used to control the frame frequency for a LCD panel.

CSb	RS	RDb	WRb	RE ₂	RE ₁	RE ₀
0	1	1	0	1	0	0

D ₇	D ₆	D ₅	D ₄	D ₃	D ₂	D ₁	D ₀
1	1	0	1	*	Rf ₂	Rf ₁	Rf ₀

- Rfx register (x=0, 1, 2)

The "Rfx" register is used to determine the feed back resistor value for the internal oscillator and it is possible to adjust the frame frequency for the LCD modules.

Rf 2	Rf 1	Rf 0	Feedback resistor value
0	0	0	Reference value
0	0	1	0.8 x reference value
0	1	0	0.9 x reference value
0	1	1	1.1 x reference value
1	0	0	1.2 x reference value
1	0	1	0.7 x reference value
1	1	0	1.3 x reference value
1	1	1	Inhibited

(32-22) Discharge ON/OFF

Discharge circuit is used to discharge the electric charge of the capacitors on the V₁ to V₄ and the V_{LCD} terminals. The "Discharge ON/OFF" instruction is usually required just after the internal power supply is turned off by setting "0" into the "DCON" and "AMPON" registers, or just after the external power supply is turned off. During the discharge operation, the internal or external power supply must not be turned on.

CSb	RS	RDb	WRb	RE ₂	RE ₁	RE ₀
0	1	1	0	1	0	0

D ₇	D ₆	D ₅	D ₄	D ₃	D ₂	D ₁	D ₀
1	1	1	0	*	*	DIS2	DIS

DIS=0: Discharge OFF (Capacitors on the V_{LCD}, V₁, V₂, V₃ and V₄)

DIS=1: Discharge ON (Capacitors on the V_{LCD}, V₁, V₂, V₃ and V₄)

DIS2=0: Discharge OFF (Resistance between V_{OUT} and V_{EE})

DIS2=1: Discharge ON (Resistance between V_{OUT} and V_{EE})

Note) V_{OUT} and V_{EE} are internally connected with the resistor (100kΩ typical) in the power-ON.

(32-23) Instruction register address

The "Instruction register address" is used to specify the instruction register address, so that it is possible to read out the contents of the instruction registers in combination with the "Instruction register read" instruction.

CSb	RS	RDb	WRb	RE ₂	RE ₁	RE ₀
0	1	1	0	1	0	0

D ₇	D ₆	D ₅	D ₄	D ₃	D ₂	D ₁	D ₀
1	1	0	0	RA ₃	RA ₂	RA ₁	RA ₀

(32-24) Instruction register read

The "Instruction register read" instruction is used to read out the contents of the instruction register in combination with the "Instruction register address" instruction.

CSb	RS	RDb	WRb	RE ₂	RE ₁	RE ₀
0	1	0	1	0/1	0/1	0/1

D ₇	D ₆	D ₅	D ₄	D ₃	D ₂	D ₁	D ₀
*	*	*	*	Internal register data read			

(32-25) Window end column address

The "Window end column address" is used to specify the column address for the window end point. The lower 4-bit data is required to be programmed first and then the upper 4-bit data can be programmed.

CSb	RS	RDb	WRb	RE ₂	RE ₁	RE ₀
0	1	1	0	1	0	1

D ₇	D ₆	D ₅	D ₄	D ₃	D ₂	D ₁	D ₀
0	0	0	0	EX ₃	EX ₂	EX ₁	EX ₀

CSb	RS	RDb	WRb	RE ₂	RE ₁	RE ₀
0	1	1	0	1	0	1

D ₇	D ₆	D ₅	D ₄	D ₃	D ₂	D ₁	D ₀
0	0	0	1	EX ₇	EX ₆	EX ₅	EX ₄

(32-26) Window end row address set

The "Window end row address" is used to specify the row address for the window end point. The lower 4-bit data is required to be programmed first and then the upper 4-bit data can be programmed.

CSb	RS	RDb	WRb	RE ₂	RE ₁	RE ₀
0	1	1	0	1	0	1

D ₇	D ₆	D ₅	D ₄	D ₃	D ₂	D ₁	D ₀
0	0	1	0	EY ₃	EY ₂	EY ₁	EY ₀

CSb	RS	RDb	WRb	RE ₂	RE ₁	RE ₀
0	1	1	0	1	0	1

D ₇	D ₆	D ₅	D ₄	D ₃	D ₂	D ₁	D ₀
0	0	1	1	*	EY ₆	EY ₅	EY ₄

(32-27) Initial reverse line

The "Initial reverse line" instruction is used to specify the initial reverse line address for the reverse line display. Lower 4-bit data must be programmed first, next upper 3-bit data. It is programmed in between 00_H and 7F_H and the line address beyond 7F_H is inhibited. The address relation: LSi < LEi (i=7 to 0) must be maintained in the reverse line display.

CSb	RS	RDb	WRb	RE ₂	RE ₁	RE ₀
0	1	1	0	1	0	1

D ₇	D ₆	D ₅	D ₄	D ₃	D ₂	D ₁	D ₀
0	1	0	0	LS ₃	LS ₂	LS ₁	LS ₀

CSb	RS	RDb	WRb	RE ₂	RE ₁	RE ₀
0	1	1	0	1	0	1

D ₇	D ₆	D ₅	D ₄	D ₃	D ₂	D ₁	D ₀
0	1	0	1	*	LS ₆	LS ₅	LS ₄

(32-28) Last reverse line

The "Last reverse line" instruction is used to specify the last reverse line address for the reverse line display. Lower 4-bit must be programmed first, next upper 3-bit data. It is programmed in between 00_H and 7F_H and the line address beyond 7F_H is inhibited. The address relation: LSi < LEi (i=7 to 0) must be maintained in the reverse line display.

CSb	RS	RDb	WRb	RE ₂	RE ₁	RE ₀
0	1	1	0	1	0	1

D ₇	D ₆	D ₅	D ₄	D ₃	D ₂	D ₁	D ₀
0	1	1	0	LE ₃	LE ₂	LE ₁	LE ₀

CSb	RS	RDb	WRb	RE ₂	RE ₁	RE ₀
0	1	1	0	1	0	1

D ₇	D ₆	D ₅	D ₄	D ₃	D ₂	D ₁	D ₀
0	1	1	1	*	LE ₆	LE ₅	LE ₄

(32-29) Reverse line display ON/OFF

The "Reverse line display ON/OFF" is used to enable or disable the reverse line display for the blink operation and determine the reverse line display mode.

CSb	RS	RDb	WRb	RE ₂	RE ₁	RE ₀
0	1	1	0	1	0	1

D ₇	D ₆	D ₅	D ₄	D ₃	D ₂	D ₁	D ₀
1	0	0	0	*	*	BT	LREV

● LREV register

The "LREV" register is used to enable or disable the reverse line display.

LREV =0: Reverse line display OFF (Normal)

LREV =1: Reverse line display ON

- BT register

The "BT" register is used to determine the reverse line display mode in the reverse line display ON (LREV=1) status.

- BT =0: Normal reverse line display
- BT =1: Blink once every 32 frames

Display examples in the LREV="1" and BT="1"

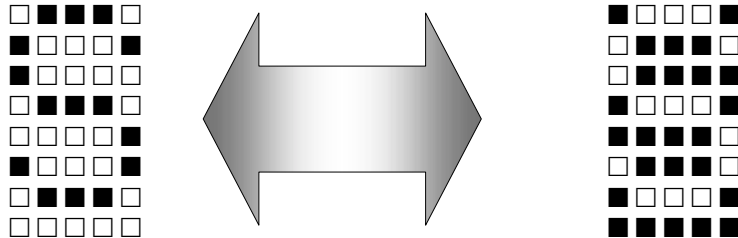

Blink once every 32 frames

**NJRC
LCD DRIVER
Low Power and
Low Voltage**

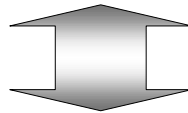

Blink once every 32 frames

NJRC
LCD DRIVER
**Low Power and
Low Voltage**

←Initial reverse line address

←Last reverse line address

(32-30) Gradation palette setting control / Icon SEG address set

CSb	RS	RDb	WRb	RE ₂	RE ₁	RE ₀
0	1	1	0	1	0	1

D ₇	D ₆	D ₅	D ₄	D ₃	D ₂	D ₁	D ₀
1	0	0	1	*	*	DMY	PS

- PS register

PS=0: Lower 8 Gradation setting

PS=1: Upper 8 Gradation setting

- DMY register

Although segment drivers in normal condition output LCD driving voltage corresponding to data in Display data RAM, Icon segment driver output LCD driving voltage corresponding to registers. The 24 bits register corresponds to SEGSA0 ~ SEGSA1, SEGSB0 ~ SEGSB1, SEGSC0 ~ SEGSC1.

DMY=0: Normal RAM access

DMY=1: Icon segment driver RAM access

(32-31)PWM control

The "PWM control" is used to determine the PWM type for the segment waveforms, where the type can be specified for each of the SEG*A*_i, SEG*B*_i and SEG*C*_i (i=0-127) drivers.

CS _b	RS	RDb	WRb	RE ₂	RE ₁	RE ₀
0	1	1	0	1	0	1

D ₇	D ₆	D ₅	D ₄	D ₃	D ₂	D ₁	D ₀
1	0	1	0	PWMS	PWMA	PWMB	PWMC

- PWMS register

PWMS=0: Type 1
 PWMS=1: Type 2

- PWMA, B and C registers

The "PWMA, PWMB and PWMC" registers are used to select the type 1-O or type 1-E.

PWMZ=0 (Z=A, B and C): Type 1-O
 PWMZ=1 (Z=A, B and C): Type 1-E

PWM type1 (PWMS="0")

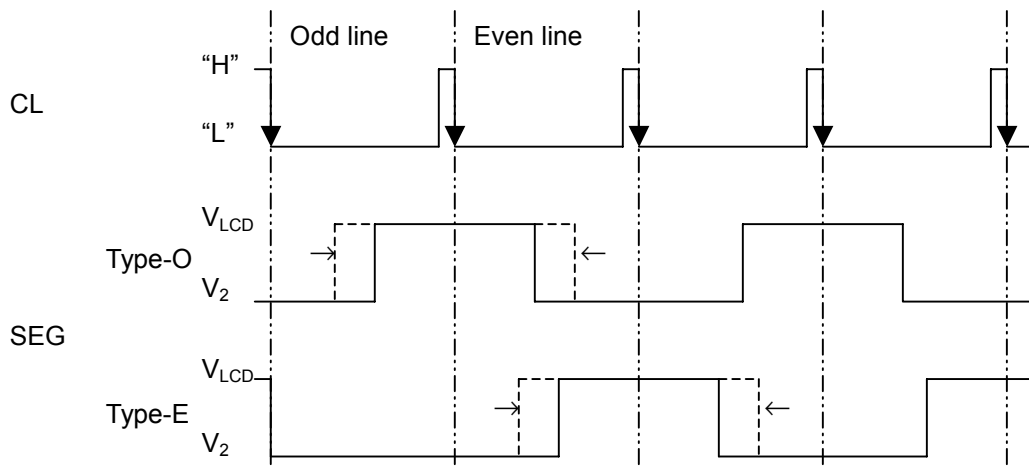

PWM type2 (PWMS="1")

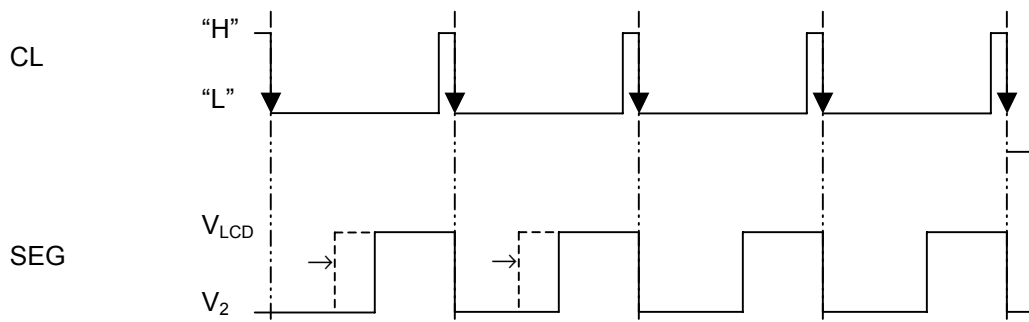

(33) The relationship between Common drivers and row addresses

Row address assignment of common drivers is programmed by the "SHIFT" register of the "Display control (1)", "Duty cycle ratio", "Internal display line" and "Initial COM line" instructions.

- When initial display line is "0"
If the "SHIFT" is "0", the scan direction is normal. When the "LA₀ to LA₆" registers of the "Initial display line" instruction is "0", the "MY" corresponding to the initial COM line is "0" and is increasing during display.
- When initial display line is not "0"
If the "SHIFT" is "1", the scan direction is inversed. When the "LA₀ to LA₆" registers of the "Initial display line" instruction is not "0", the "MY" corresponding to the initial COM line is this setting value and is increasing during display.

The following are examples of setting the start-line 0 or 5 at 1/129, 1/128, or 1/17 duty.

(33-2) Initial display line "0", 1/17 duty cycle (Common forward scan)

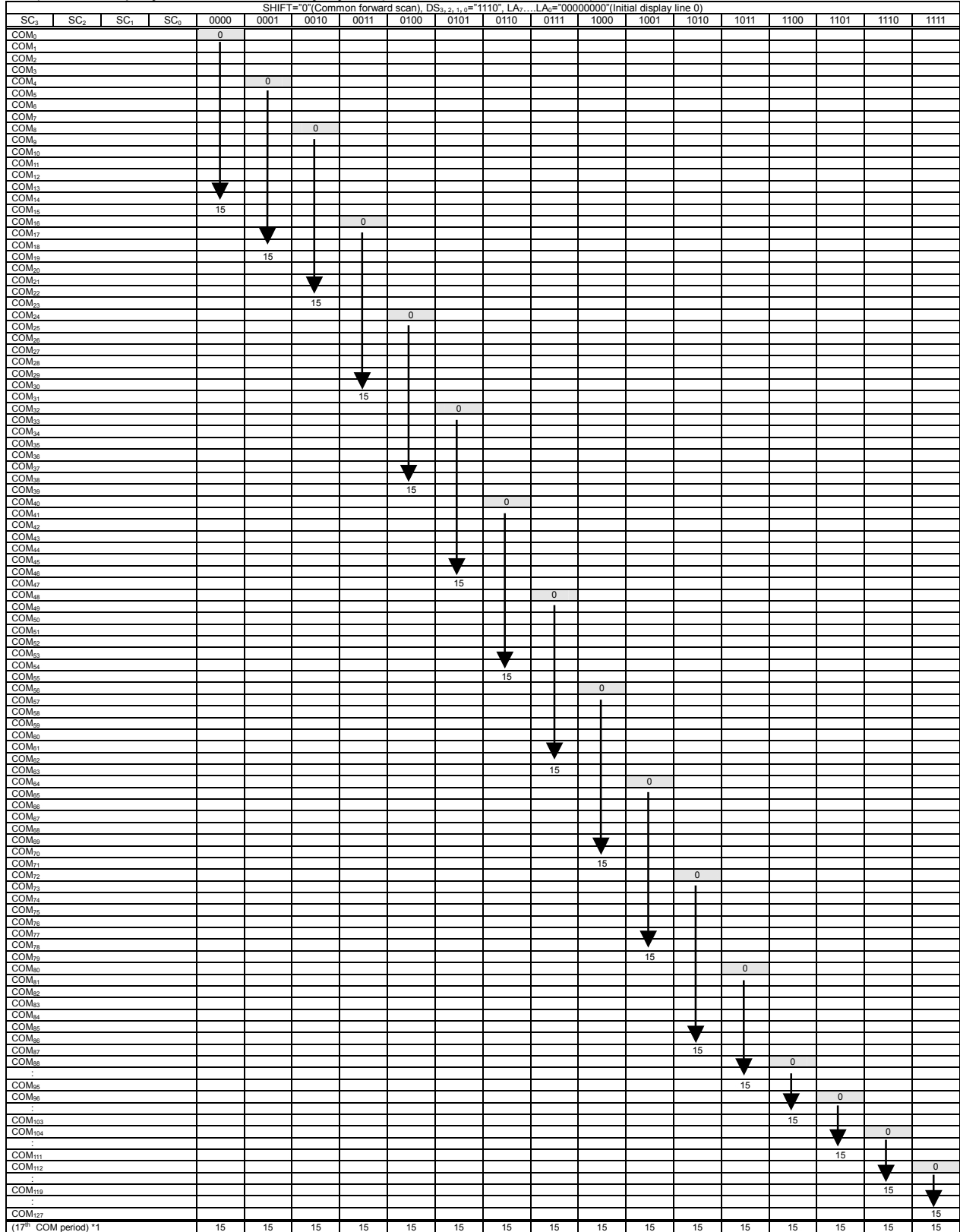

DS: Duty cycle ratio, SC: Initial COM line, LA: Initial display line
 *1 : 17th COM period is not selected.

(33-4) Initial display line "5", 1/129 duty cycle (Common forward scan)

SHIFT="0"(Common forward scan), DS _{3,2,1,0} ="0000", LA _{7,6,5,4,3,2,1,0} ="00000101"(Initial display line 5)																			
SC ₃	SC ₂	SC ₁	SC ₀	0000	0001	0010	0011	0100	0101	0110	0111	1000	1001	1010	1011	1100	1101	1110	1111
COM ₀				5															
COM ₁					1														
COM ₂						125													
COM ₃						126													
COM ₄						127													
COM ₅						0													
COM ₆					5														
COM ₇																			
COM ₈							5												
COM ₉																			
COM ₁₀								127											
COM ₁₁								0											
COM ₁₂																			
COM ₁₃																			
COM ₁₄																			
COM ₁₅																			
COM ₁₆									5										
COM ₁₇																			
COM ₁₈										127									
COM ₁₉										0									
COM ₂₀																			
COM ₂₁																			
COM ₂₂																			
COM ₂₃																			
COM ₂₄										5									
COM ₂₅																			
COM ₂₆																			
COM ₂₇											127								
COM ₂₈											0								
COM ₂₉																			
COM ₃₀																			
COM ₃₁																			
COM ₃₂																			
COM ₃₃											5								
COM ₃₄																			
COM ₃₅																			
COM ₃₆																			
COM ₃₇																			
COM ₃₈																			
COM ₃₉																			
COM ₄₀																			
COM ₄₁																			
COM ₄₂																			
COM ₄₃																			
COM ₄₄																			
COM ₄₅																			
COM ₄₆																			
COM ₄₇																			
COM ₄₈																			
COM ₄₉																			
COM ₅₀																			
COM ₅₁																			
COM ₅₂																			
COM ₅₃																			
COM ₅₄																			
COM ₅₅																			
COM ₅₆																			
COM ₅₇																			
COM ₅₈																			
COM ₅₉																			
COM ₆₀																			
COM ₆₁																			
COM ₆₂																			
COM ₆₃																			
COM ₆₄																			
COM ₆₅																			
COM ₆₆																			
COM ₆₇																			
COM ₆₈																			
COM ₆₉																			
COM ₇₀																			
COM ₇₁																			
COM ₇₂																			
COM ₇₃																			
COM ₇₄																			
COM ₇₅																			
COM ₇₆																			
COM ₇₇																			
COM ₇₈																			
COM ₇₉																			
COM ₈₀																			
COM ₈₁																			
COM ₈₂																			
COM ₈₃																			
COM ₈₄																			
COM ₈₅																			
COM ₈₆																			
COM ₈₇																			
COM ₈₈																			
COM ₈₉																			
COM ₉₀																			
COM ₉₁																			
COM ₉₂																			
COM ₉₃																			
COM ₉₄																			
COM ₉₅																			
COM ₉₆																			
COM ₉₇																			
COM ₉₈																			
COM ₉₉																			
COM ₁₀₀																			
COM ₁₀₁																			
COM ₁₀₂																			
COM ₁₀₃																			
COM ₁₀₄																			
COM ₁₀₅																			
COM ₁₀₆																			
COM ₁₀₇																			
COM ₁₀₈																			
COM ₁₀₉																			
COM ₁₁₀																			
COM ₁₁₁																			
COM ₁₁₂																			
COM ₁₁₃																			
COM ₁₁₄																			
COM ₁₁₅																			
COM ₁₁₆																			
COM ₁₁₇																			
COM ₁₁₈																			
COM ₁₁₉																			
COM ₁₂₀																			
COM ₁₂₁																			
COM ₁₂₂																			
COM ₁₂₃																			
COM ₁₂₄																			
COM ₁₂₅																			
COM ₁₂₆																			

(33-5) Initial display line "0", 1/128 duty cycle (Common forward scan, DSE="1")

		SHIFT="0" (Common forward scan), DS _{2-1,0} ="0000", LA _{7-1,0} ="00000000" (Initial display line 0) DSE="1"																	
SC ₃	SC ₂	SC ₁	SC ₀	0000	0001	0010	0011	0100	0101	0110	0111	1000	1001	1010	1011	1100	1101	1110	1111
COM ₀				0	124	120	112	104	96	88	80	72	64	56	48	40	32	24	16
COM ₁					127														
COM ₂																			
COM ₃					0														
COM ₄																			
COM ₅																			
COM ₆																			
COM ₇						127													
COM ₈						0													
COM ₉																			
COM ₁₀																			
COM ₁₁																			
COM ₁₂																			
COM ₁₃																			
COM ₁₄																			
COM ₁₅								127											
COM ₁₆								0											
COM ₁₇																			
COM ₁₈																			
COM ₁₉																			
COM ₂₀																			
COM ₂₁																			
COM ₂₂																			
COM ₂₃																			
COM ₂₄																			
COM ₂₅																			
COM ₂₆																			
COM ₂₇																			
COM ₂₈																			
COM ₂₉																			
COM ₃₀																			
COM ₃₁																			
COM ₃₂																			
COM ₃₃																			
COM ₃₄																			
COM ₃₅																			
COM ₃₆																			
COM ₃₇																			
COM ₃₈																			
COM ₃₉																			
COM ₄₀																			
COM ₄₁																			
COM ₄₂																			
COM ₄₃																			
COM ₄₄																			
COM ₄₅																			
COM ₄₆																			
COM ₄₇																			
COM ₄₈																			
COM ₄₉																			
COM ₅₀																			
COM ₅₁																			
COM ₅₂																			
COM ₅₃																			
COM ₅₄																			
COM ₅₅																			
COM ₅₆																			
COM ₅₇																			
COM ₅₈																			
COM ₅₉																			
COM ₆₀																			
COM ₆₁																			
COM ₆₂																			
COM ₆₃																			
COM ₆₄																			
COM ₆₅																			
COM ₆₆																			
COM ₆₇																			
COM ₆₈																			
COM ₆₉																			
COM ₇₀																			
COM ₇₁																			
COM ₇₂																			
COM ₇₃																			
COM ₇₄																			
COM ₇₅																			
COM ₇₆																			
COM ₇₇																			
COM ₇₈																			
COM ₇₉																			
COM ₈₀																			
COM ₈₁																			
COM ₈₂																			
COM ₈₃																			
COM ₈₄																			
COM ₈₅																			
COM ₈₆																			
COM ₈₇																			
COM ₈₈																			
COM ₈₉																			
COM ₉₀																			
COM ₉₁																			
COM ₉₂																			
COM ₉₃																			
COM ₉₄																			
COM ₉₅																			
COM ₉₆																			
COM ₉₇																			
COM ₉₈																			
COM ₉₉																			
COM ₁₀₀																			
COM ₁₀₁																			
COM ₁₀₂																			
COM ₁₀₃																			
COM ₁₀₄																			
COM ₁₀₅																			
COM ₁₀₆																			
COM ₁₀₇																			
COM ₁₀₈																			
COM ₁₀₉																			
COM ₁₁₀																			
COM ₁₁₁																			
COM ₁₁₂																			
COM ₁₁₃																			
COM ₁₁₄																			
COM ₁₁₅																			
COM ₁₁₆																			
COM ₁₁₇																			
COM ₁₁₈																			
COM ₁₁₉																			
COM ₁₂₀																			
COM ₁₂₁																			
COM ₁₂₂																			

DS: Duty cycle ratio, SC: Initial COM line, LA: Initial display line

■ ABSOLUTE MAXIMUM RATINGS

PARAMETER	SYMBOL	CONDITION	TERMINAL	RATING	UNIT
Supply Voltage (1)	V_{DD}	$V_{SS}=0V$ $T_a = +25^\circ C$	V_{DD}	-0.3 to +4.0	V
Supply Voltage (2)	V_{EE}		V_{EE}	-0.3 to +4.0	V
Supply Voltage (3)	V_{OUT}		V_{OUT}	-0.3 to +20.0	V
Supply Voltage (4)	V_{REG}		V_{REG}	-0.3 to +20.0	V
Supply Voltage (5)	V_{LCD}		V_{LCD}	-0.3 to +20.0	V
Supply Voltage (6)	V_1, V_2, V_3, V_4		V_1, V_2, V_3, V_4	-0.3 to $V_{LCD} + 0.3$	V
Input Voltage	V_I		*1	-0.3 to $V_{DD} + 0.3$	V
Storage Temperature	T_{stg}			-45 to +125	°C

Note 1) D_0 to D_{15} , CSb, RS, RDb, WRb, OSC₁, RESb terminals.

■ RECOMMENDED OPERATING CONDITIONS

PARAMETER	SYMBOL	TERMINAL	MIN	TYP	MAX	UNIT	NOTE
Supply Voltage	V_{DD1}	V_{DD}	1.7		3.3	V	*1
	V_{DD2}		2.4		3.3	V	*2
		V_{EE}	2.4		3.3	V	*3
Operating Voltage	V_{LCD}	V_{LCD}	5		18.0	V	*4
	V_{OUT}	V_{OUT}			18.0	V	
	V_{REG}	V_{REG}			$V_{OUT} \times 0.9$	V	
	V_{REF}	V_{REF}	2.1		3.3	V	*5
Operating Temperature	T_{opr}		-30		85	°C	

Note1) Applies to the condition when the reference voltage generator is not used.

Note2) Applies to the condition when the reference voltage generator is used.

Note3) Applies to the condition when the voltage booster is used.

Note4) The following relationship among the supply voltages must be maintained.

$$V_{SS} < V_4 < V_3 < V_2 < V_1 < V_{LCD} \leq V_{OUT}$$

Note5) The relationship: $V_{REF} < V_{EE}$ must be maintained.

DC CHARACTERISTICS 1

$V_{SS} = 0V, V_{DD} = +1.7 \text{ to } +3.3V, T_a = -30 \text{ to } +85^\circ\text{C}$

PARAMETER	SYM BOL	CONDITION	MIN	TYP	MAX	UNIT	NOTE	
High level input voltage	V_{IH}		$0.8 V_{DD}$		V_{DD}	V	*1	
Low level input voltage	V_{IL}		0		$0.2V_{DD}$	V	*1	
High level output voltage	V_{OH1}	$I_{OH} = -0.4\text{mA}$	$V_{DD} - 0.4$			V	*2	
Low level output voltage	V_{OL1}	$I_{OL} = 0.4\text{mA}$			0.4	V	*2	
High level output voltage	V_{OH2}	$I_{OH} = -0.1\text{mA}$	$V_{DD} - 0.4$			V	*3	
Low level output voltage	V_{OL2}	$I_{OL} = 0.1\text{mA}$			0.4	V	*3	
Input leakage current	I_{LI}	$V_i = V_{SS} \text{ or } V_{DD}$	-10		10	μA	*4	
Output leakage current	I_{LO}	$V_i = V_{SS} \text{ or } V_{DD}$	-10		10	μA	*5	
Driver ON-resistance	R_{ON1}	$ \Delta V_{ON} = 0.5V$	$V_{LCD} = 10V$	1	2	k Ω	*6	
			$V_{LCD} = 6V$	2	4			
Stand-by current	I_{STB}	$CS = V_{DD}, T_a = 25^\circ\text{C}$			15	μA	*7	
Internal oscillation Frequency	f_{OSC1}	$V_{DD} = 3V$ $T_a = 25^\circ\text{C}$		490	600	710	kHz	*8
	f_{OSC2}			110	135.5	160		*9
	f_{OSC3}			15.9	19.4	22.9		*10
External oscillation Frequency	f_{r1}	$R_f = 15\text{k}\Omega$		575		kHz	*11	
	f_{r2}	$R_f = 68\text{k}\Omega$		135				
	f_{r3}	$R_f = 510\text{k}\Omega$		19.6				
Voltage converter output voltage	V_{OUT}	N-time booster (N=2 to 6) $R_L = 500\text{k}\Omega (V_{OUT} - V_{SS})$	$(N \times V_{EE})$ $\times 0.95$			V	*12	
Supply current (1)	I_{DD1}	$V_{DD} = 3V$, 6-time booster Whole ON pattern		760	1140	μA	*13	
Supply current (2)	I_{DD2}	$V_{DD} = 3V$, 6-time booster Checker pattern		930	1400			
Supply current (3)	I_{DD3}	$V_{DD} = 3V$, 5-time booster Whole ON pattern		520	780			
Supply current (4)	I_{DD4}	$V_{DD} = 3V$, 5-time booster Checker pattern		650	980			
Supply current (5)	I_{DD5}	$V_{DD} = 3V$, 4-time booster Whole ON pattern		360	540			
Supply current (6)	I_{DD6}	$V_{DD} = 3V$, 4-time booster Checker pattern		450	680			
V_{BA} Operating voltage	V_{BA}	$V_{EE} = 2.4 \text{ to } 3.3V$	$(0.9 V_{EE})$ $\times 0.98$	$0.9 V_{EE}$	$(0.9 V_{EE})$ $\times 1.02$	V	*14	
V_{REG} Operating voltage	V_{REG}	$V_{EE} = 2.4 \text{ to } 3.3V$ $V_{REF} = 0.9 \times V_{EE}$ N-time booster (N=2 to 6)	$(V_{REF} \times N)$ $\times 0.97$	$(V_{REF} \times N)$	$(V_{REF} \times N)$ $\times 1.03$	V	*15	
Output Voltage	V_2		-100	0	+100	mV	*16	
	V_3		-100	0	+100			
	V_{D12}		-30	0	+30			
	V_{D34}		-30	0	+30			
	V_{D24}		-30	0	+30			

■ CLOCK and FRAME FREQUENCY

PARAMETER	SYMBOL	Display mode	Display duty cycle ratio (1/D) <DSE=0>				NOTE
			1/129 to 1/81	1/73 to 1/41	1/33 to 1/25	1/17	
Internal clock	f_{osc}	16 Gradation mode	$f_{osc} / (62xD)$	$f_{osc} / (62xDx2)$	$f_{osc} / (62xDx4)$	$f_{osc} / (62xDx8)$	FLM
		Simplified 8 gradation mode	$f_{osc} / (14xD)$	$f_{osc} / (14xDx2)$	$f_{osc} / (14xDx4)$	$f_{osc} / (14xDx8)$	
		B&W mode	$f_{osc} / (2xD)$	$f_{osc} / (2xDx2)$	$f_{osc} / (2xDx4)$	$f_{osc} / (2xDx8)$	
External clock	f_{ck}	16 Gradation mode	$f_{ck} / (62xD)$	$f_{ck} / (62xDx2)$	$f_{ck} / (62xDx4)$	$f_{ck} / (62xDx8)$	
		Simplified 8 gradation mode	$f_{ck} / (14xD)$	$f_{ck} / (14xDx2)$	$f_{ck} / (14xDx4)$	$f_{ck} / (14xDx8)$	
		B&W mode	$f_{ck} / (2xD)$	$f_{ck} / (2xDx2)$	$f_{ck} / (2xDx4)$	$f_{ck} / (2xDx8)$	

APPLIED TERMINALS and CONDITIONS

- Note 1) D_0 - D_{15} , CSb, RS, RDb, WRb, P/S, SEL68, RESb
 Note 2) D_0 - D_{15}
 Note 3) CL, FLM, FR, CLK
 Note 4) CSb, RS, SEL68, RDb, WRb, P/S, RESb, OSC₁
 Note 5) D_0 - D_{15} in the high impedance
- Note 6) - SEGA₀-SEGA₁₂₇, SEGB₀-SEGB₁₂₇, SEGC₀-SEGC₁₂₇, COM₀-COM₁₂₇ and
 SEGSA₀-SEGSA₁, SEGSB₀-SEGSB₁, SEGSC₀-SEGSC₁
 - Defines the resistance between the COM/SEG terminals and the power supply terminals (V_{LCD} , V_1 , V_2 , V_3 and V_4) at the condition of 0.5V deference and 1/9 LCD bias ratio.
- Note 7) V_{DD}
 - The oscillator is halted, CSb="1" (disabled), No-load on the COM/SEG drivers
- Note 8) OSC
 - Defines the internal oscillation frequency at (Rf_2 , Rf_1 , Rf_0)=(0,0,0) in the variable gradation mode.
- Note 9) OSC
 - Defines the internal oscillation frequency at (Rf_2 , Rf_1 , Rf_0)=(0,0,0) in the fixed gradation mode.
- Note 10) OSC
 - Defines the internal oscillation frequency at (Rf_2 , Rf_1 , Rf_0)=(0,0,0) in the Black & White mode.
- Note 11) V_{DD} =3V, T_a =25°C
- Note 12) V_{OUT}
 - Applies to the condition when the internal voltage booster, the internal oscillator and the internal power circuits are used.
 - V_{EE} =2.4V to 3.3V, EVR= (1,1,1,1,1,1,1), 1/5 to 1/12 LCD bias, 1/129 duty cycle, No-load on COM/SEG drivers.
 - RL=500KΩ between the V_{OUT} and the V_{SS} , CA₁=CA₂=1.0uF, CA₃=0.1uF, DCON="1", AMPON="1"
- Note 13) V_{DD}
 - Applies to the condition using the internal oscillator and internal power circuits, no access between the LSI and MPU.
 - EVR= (1,1,1,1,1,1,1), All pixels turned-on or checkerboard display in gradation mode. No-load on the COM/SEG drivers.
 - V_{DD} = V_{EE} , V_{REF} =0.9 V_{EE} , CA₁=CA₂=1.0uF, CA₃=0.1uF, DCON="1", AMPON="1", NLIN="0", 1/129 Duty cycle, T_a =25°C
- Note 14) V_{BA}
 - Applies to the condition that V_{BA} = V_{REF} and voltage booster N= 1. DCON="0", V_{OUT} =13.5V input.
- Note 15) V_{REG}
 - V_{EE} =2.4V to 3.3V, V_{REF} =0.9 V_{EE} , V_{OUT} =18V, 1/5 to 1/12 LCD bias ratio, 1/129 duty cycle, EVR=(1,1,1,1,1,1,1)
 - Checkerboard display, No-load on the COM/SEG drivers, the voltage booster N=2 to 6, V_1A_1 , V_1A_2 , V_4A_1 , V_4A_2 = "0". CA₁=CA₂=1.0uF, CA₃=0.1uF, DCON="0", AMPON="1", NLIN="0"
- Note 16) V_{LCD} , V_1 , V_2 , V_3 , V_4
 - V_{EE} =3.0V, V_{REF} =0.9 V_{EE} , V_{OUT} =15V, 1/5 to 1/12 LCD Bias, EVR= (1,1,1,1,1,1,1), Display OFF, No-load on the COM/SEG drivers, voltage booster N=5, V_1A_1 , V_1A_2 , V_4A_1 , V_4A_2 = "0". CA₁=CA₂=1.0uF, CA₃=0.1uF, DCON="0", AMPON="1"

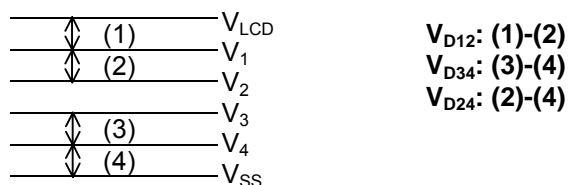

AC CHARACTERISTICS

- Write operation (80-type MPU)

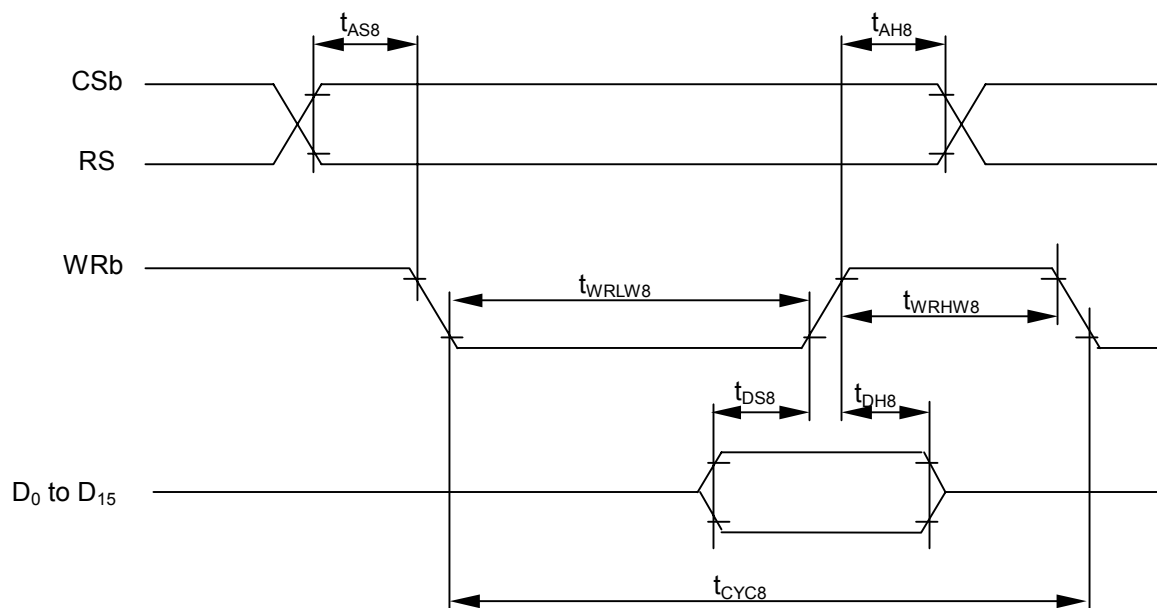

($V_{DD}=2.5$ to $3.3V$, $T_a=-30$ to $+85^{\circ}C$)

PARAMETER	SYMBOL	CONDITION	MIN.	MAX.	UNIT	TERMINAL
Address hold time	t_{AH8}		0		ns	CSb
Address setup time	t_{AS8}		0		ns	RS
System cycle time	t_{CYC8}		90		ns	
Enable "L" level pulse width	t_{WRLW8}		35		ns	WRb
Enable "H" level pulse width	t_{WRHW8}		35		ns	
Data setup time	t_{DS8}		30		ns	D ₀ to D ₁₅
Data hold time	t_{DH8}		5		ns	

($V_{DD}=2.2$ to $2.5V$, $T_a=-30$ to $+85^{\circ}C$)

PARAMETER	SYMBOL	CONDITION	MIN.	MAX.	UNIT	TERMINAL
Address hold time	t_{AH8}		0		ns	CSb
Address setup time	t_{AS8}		0		ns	RS
System cycle time	t_{CYC8}		160		ns	
Enable "L" level pulse width	t_{WRLW8}		70		ns	WRb
Enable "H" level pulse width	t_{WRHW8}		70		ns	
Data setup time	t_{DS8}		40		ns	D ₀ to D ₁₅
Data hold time	t_{DH8}		5		ns	

($V_{DD}=1.7$ to $2.2V$, $T_a=-30$ to $+85^{\circ}C$)

PARAMETER	SYMBOL	CONDITION	MIN.	MAX.	UNIT	TERMINAL
Address hold time	t_{AH8}		0		ns	CSb
Address setup time	t_{AS8}		0		ns	RS
System cycle time	t_{CYC8}		180		ns	
Enable "L" level pulse width	t_{WRLW8}		80		ns	WRb
Enable "H" level pulse width	t_{WRHW8}		80		ns	
Data setup time	t_{DS8}		70		ns	D ₀ to D ₁₅
Data hold time	t_{DH8}		10		ns	

Note) Each timing is specified based on 20% and 80% of V_{DD} .

NJU6824

● Read operation (80-type MPU)

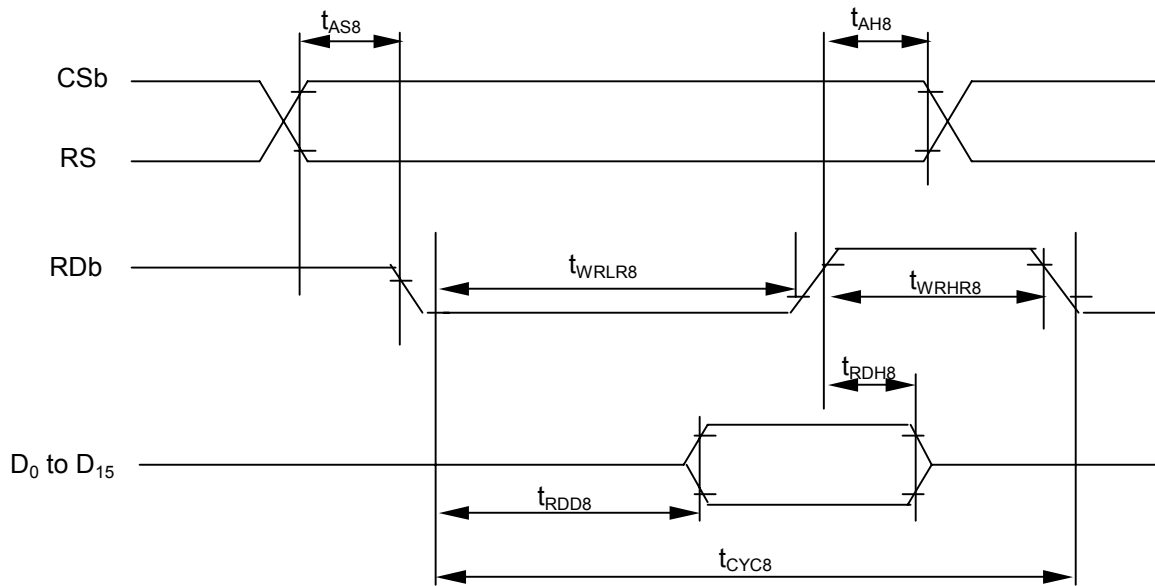

($V_{DD}=2.5$ to $3.3V$, $T_a=-30$ to $+85^{\circ}C$)

PARAMETER	SYMBOL	CONDITION	MIN.	MAX.	UNIT	TERMINAL
Address hold time	t_{AH8}		0		ns	CSb
Address setup time	t_{AS8}		0		ns	RS
System cycle time	t_{CYC8}		180		ns	RDb
Enable "L" level pulse width	t_{WRLR8}		80		ns	
Enable "H" level pulse width	t_{WRHR8}		80		ns	
Read Data delay time	T_{RDD8}	CL=15pF	0	60	ns	D ₀ to D ₁₅
Read Data hold time	T_{RDH8}				ns	

($V_{DD}=2.2$ to $2.5V$, $T_a=-30$ to $+85^{\circ}C$)

PARAMETER	SYMBOL	CONDITION	MIN.	MAX.	UNIT	TERMINAL
Address hold time	t_{AH8}		0		ns	CSb
Address setup time	t_{AS8}		0		ns	RS
System cycle time	t_{CYC8}		180		ns	RDb
Enable "L" level pulse width	t_{WRLR8}		80		ns	
Enable "H" level pulse width	t_{WRHR8}		80		ns	
Read Data delay time	T_{RDD8}	CL=15pF	0	60	ns	D ₀ to D ₁₅
Read Data hold time	T_{RDH8}				ns	

($V_{DD}=1.7$ to $2.2V$, $T_a=-30$ to $+85^{\circ}C$)

PARAMETER	SYMBOL	CONDITION	MIN.	MAX.	UNIT	TERMINAL
Address hold time	t_{AH8}		0		ns	CSb
Address setup time	t_{AS8}		0		ns	RS
System cycle time	t_{CYC8}		250		ns	RDb
Enable "L" level pulse width	t_{WRLR8}		120		ns	
Enable "H" level pulse width	t_{WRHR8}		120		ns	
Read Data delay time	t_{RDD8}	CL=15pF	0	110	ns	D ₀ to D ₁₅
Read Data hold time	t_{RDH8}				ns	

Note) Each timing is specified based on 20% and 80% of V_{DD} .

● Write operation (68-type MPU)

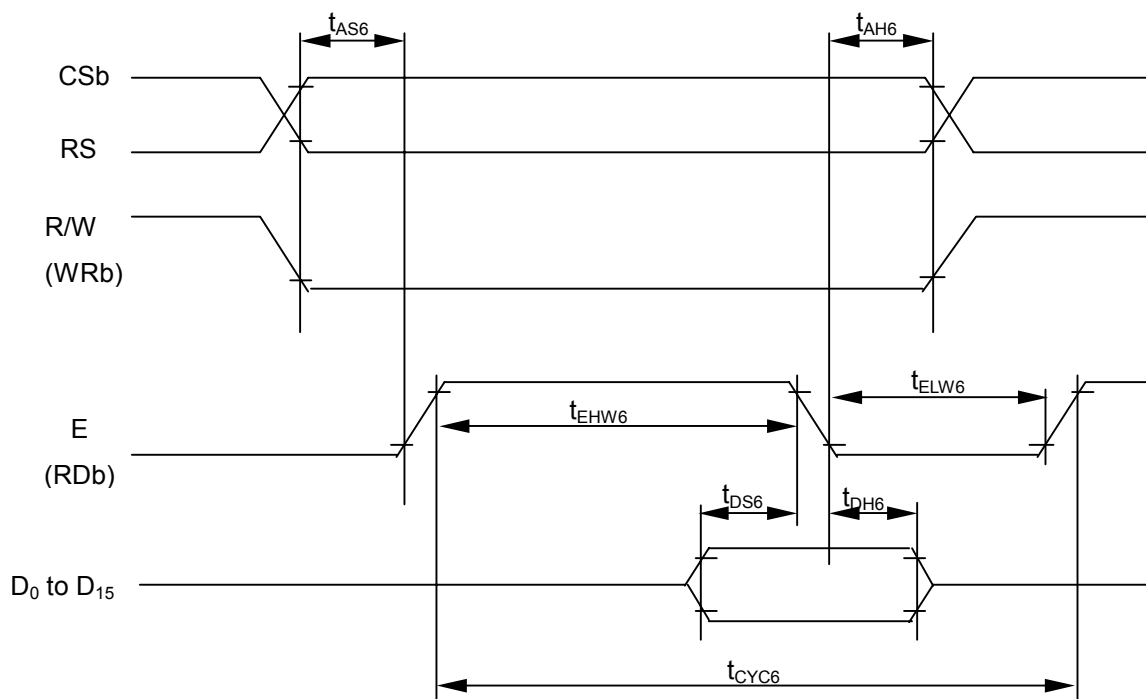

($V_{DD}=2.5$ to $3.3V$, $T_a=-30$ to $+85^{\circ}C$)

PARAMETER	SYMBOL	CONDITION	MIN.	MAX.	UNIT	TERMINAL
Address hold time	t_{AH6}		0		ns	CSb
Address setup time	t_{AS6}		0		ns	RS
System cycle time	t_{CYC6}		90		ns	E
Enable "L" level pulse width	t_{ELW6}		35		ns	
Enable "H" level pulse width	t_{EHW6}		35		ns	
Data setup time	t_{DS6}		40		ns	D ₀ to D ₁₅
Data hold time	t_{DH6}		5		ns	

($V_{DD}=2.2$ to $2.5V$, $T_a=-30$ to $+85^{\circ}C$)

PARAMETER	SYMBOL	CONDITION	MIN.	MAX.	UNIT	TERMINAL
Address hold time	t_{AH6}		0		ns	CSb
Address setup time	t_{AS6}		0		ns	RS
System cycle time	t_{CYC6}		160		ns	E
Enable "L" level pulse width	t_{ELW6}		70		ns	
Enable "H" level pulse width	t_{EHW6}		70		ns	
Data setup time	t_{DS6}		50		ns	D ₀ to D ₁₅
Data hold time	t_{DH6}		5		ns	

($V_{DD}=1.7$ to $2.2V$, $T_a=-30$ to $+85^{\circ}C$)

PARAMETER	SYMBOL	CONDITION	MIN.	MAX.	UNIT	TERMINAL
Address hold time	t_{AH6}		0		ns	CSb
Address setup time	t_{AS6}		0		ns	RS
System cycle time	t_{CYC6}		180		ns	E
Enable "L" level pulse width	t_{ELW6}		80		ns	
Enable "H" level pulse width	t_{EHW6}		80		ns	
Data setup time	t_{DS6}		70		ns	D ₀ to D ₁₅
Data hold time	t_{DH6}		10		ns	

Note) Each timing is specified based on 20% and 80% of V_{DD} .

NJU6824

● Read operation (68-type MPU)

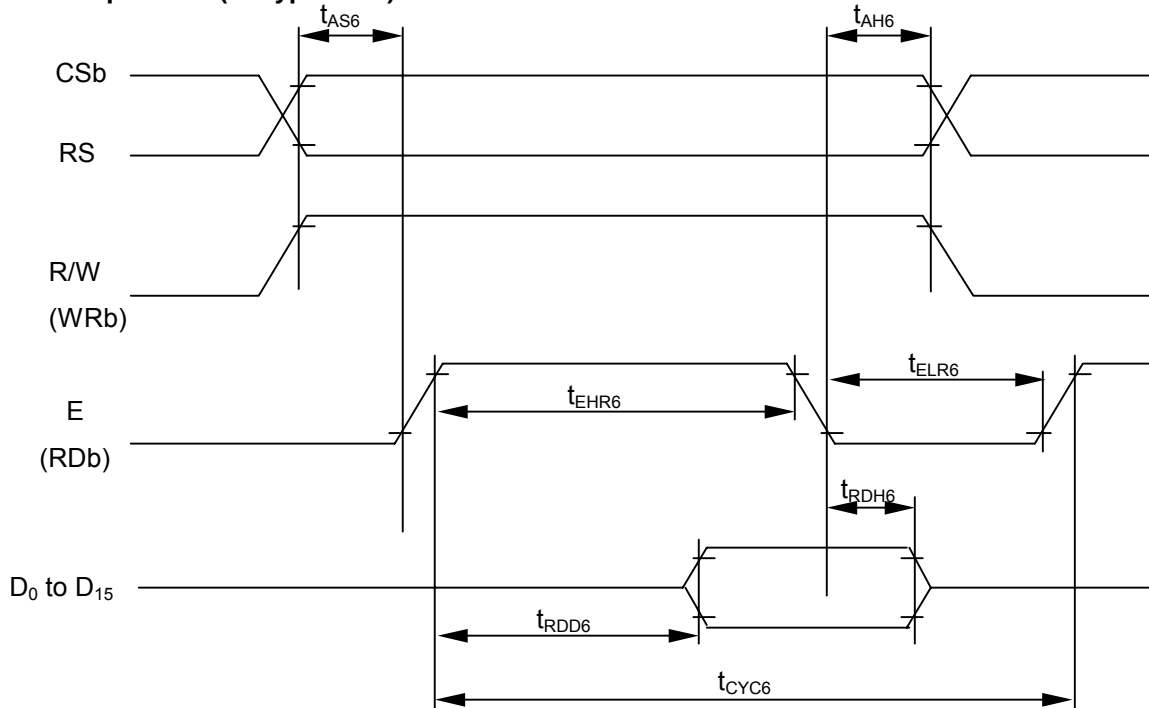

($V_{DD}=2.5$ to $3.3V$, $T_a=-30$ to $+85^{\circ}C$)

PARAMETER	SYMBOL	CONDITION	MIN.	MAX.	UNIT	TERMINAL
Address hold time Address setup time	t_{AH6} t_{AS6}		0 0		ns ns	CSb RS
System cycle time Enable "L" level pulse width Enable "H" level pulse width	t_{CYC6} t_{ELR6} t_{EHR6}		180 80 80		ns ns ns	E
Read Data delay time Read Data hold time	t_{RDD6} t_{RDH6}	CL=15pF	0	70	ns ns	D ₀ to D ₁₅

($V_{DD}=2.2$ to $2.5V$, $T_a=-30$ to $+85^{\circ}C$)

PARAMETER	SYMBOL	CONDITION	MIN.	MAX.	UNIT	TERMINAL
Address hold time Address setup time	t_{AH6} t_{AS6}		0 0		ns ns	CSb RS
System cycle time Enable "L" level pulse width Enable "H" level pulse width	t_{CYC6} t_{ELR6} t_{EHR6}		180 80 80		ns ns ns	E
Read Data delay time Read Data hold time	t_{RDD6} t_{RDH6}	CL=15pF	0	70	ns ns	D ₀ to D ₁₅

($V_{DD}=1.7$ to $2.2V$, $T_a=-30$ to $+85^{\circ}C$)

PARAMETER	SYMBOL	CONDITION	MIN.	MAX.	UNIT	TERMINAL
Address hold time Address setup time	t_{AH6} t_{AS6}		0 0		ns ns	CSb RS
System cycle time Enable "L" level pulse width Enable "H" level pulse width	t_{CYC6} t_{ELR6} t_{EHR6}		250 120 120		ns ns ns	E
Read Data delay time Read Data hold time	t_{RDD6} t_{RDH6}	CL=15pF	0	110	ns ns	D ₀ to D ₁₅

Note) Each timing is specified based on 20% and 80% of V_{DD} .

● Serial interface

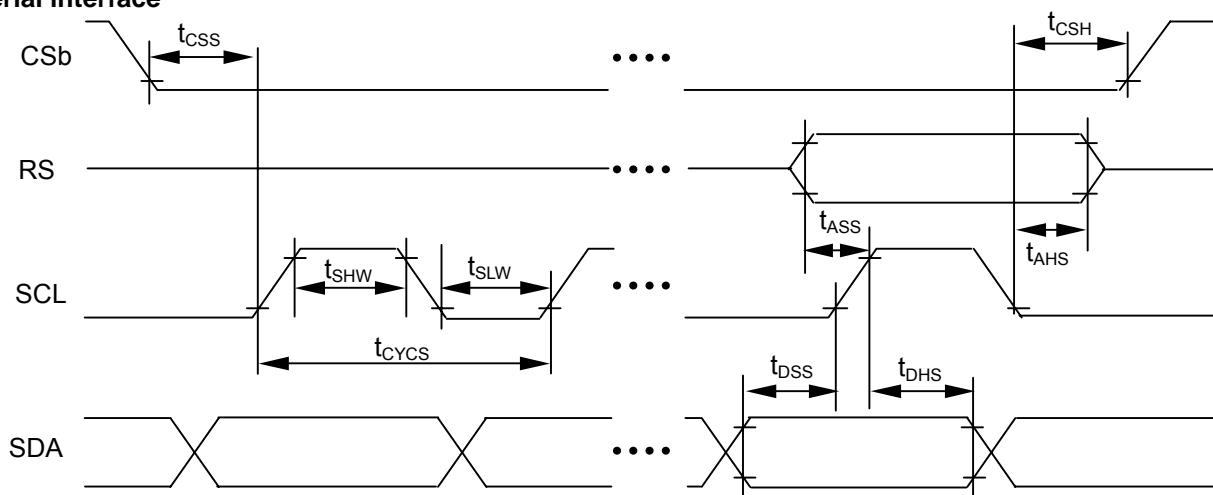

(V_{DD}=2.5 to 3.3V, Ta=-30 to +85°C)

PARAMETER	SYMBOL	CONDITION	MIN.	MAX.	UNIT	TERMINAL
Serial clock cycle	t _{CYCS}		100		ns	
SCL "H" level pulse width	t _{SHW}		45		ns	SCL
SCL "L" level pulse width	t _{SLW}		45		ns	
Address setup time	t _{ASS}		20		ns	RS
Address hold time	t _{AHS}		20		ns	
Data setup time	t _{DSS}		20		ns	SDA
Data hold time	t _{DHS}		20		ns	
CSb – SCL time	t _{CSS}		20		ns	CSb
CSb hold time	t _{CSH}		20		ns	

(V_{DD}=2.2 to 2.5V, Ta=-30 to +85°C)

PARAMETER	SYMBOL	CONDITION	MIN.	MAX.	UNIT	TERMINAL
Serial clock cycle	t _{CYCS}		100		ns	
SCL "H" level pulse width	t _{SHW}		45		ns	SCL
SCL "L" level pulse width	t _{SLW}		45		ns	
Address setup time	t _{ASS}		20		ns	RS
Address hold time	t _{AHS}		20		ns	
Data setup time	t _{DSS}		20		ns	SDA
Data hold time	t _{DHS}		20		ns	
CSb – SCL time	t _{CSS}		20		ns	CSb
CSb hold time	t _{CSH}		20		ns	

(V_{DD}=1.7 to 2.2V, Ta=-30 to +85°C)

PARAMETER	SYMBOL	CONDITION	MIN.	MAX.	UNIT	TERMINAL
Serial clock cycle	t _{CYCS}		160		ns	
SCL "H" level pulse width	t _{SHW}		75		ns	SCL
SCL "L" level pulse width	t _{SLW}		75		ns	
Address setup time	t _{ASS}		35		ns	RS
Address hold time	t _{AHS}		35		ns	
Data setup time	t _{DSS}		35		ns	SDA
Data hold time	t _{DHS}		35		ns	
CSb – SCL time	t _{CSS}		35		ns	CSb
CSb hold time	t _{CSH}		35		ns	

Note) Each timing is specified based on 20% and 80% of V_{DD}.

NJU6824

- Display control timing

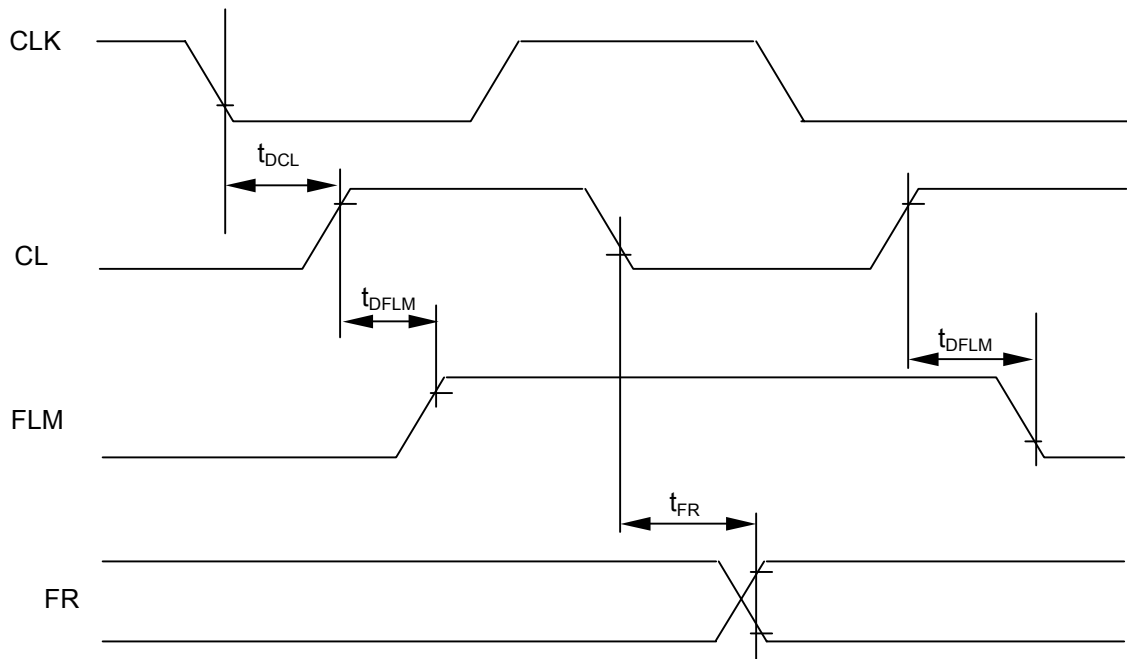

Output timing

($V_{DD}=2.4$ to $3.3V$, $T_a=-30$ to $+85^{\circ}C$)

PARAMETER	SYMBOL	CONDITION	MIN.	MAX.	UNIT	TERMINAL
FLM delay time	t_{DFLM}	CL=15pF	0	500	ns	FLM
FR delay time	t_{FR}		0	500	ns	FR
CL delay time	t_{DCL}		0	200	ns	CL

Output timing

($V_{DD}=1.7$ to $2.4V$, $T_a=-30$ to $+85^{\circ}C$)

PARAMETER	SYMBOL	CONDITION	MIN.	MAX.	UNIT	TERMINAL
FLM delay time	t_{DFLM}	CL=15pF	0	1000	ns	FLM
FR delay time	t_{FR}		0	1000	ns	FR
CL delay time	t_{DCL}		0	200	ns	CL

Note) Each timing is specified based on 20% and 80% of V_{DD} .

● Input clock timing

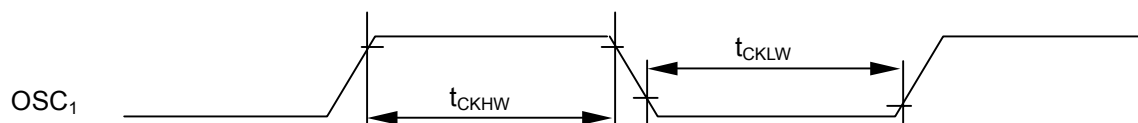

(V_{DD}=1.7 to 3.3V, Ta=-30 to +85°C)

PARAMETER	SYMBOL	CONDITION	MIN.	MAX.	UNIT	TERMINAL
OSC ₁ "H" level pulse width (1)	t _{CKHW1}		0.70	1.02	μs	OSC ₁
OSC ₁ "L" level pulse width (1)	t _{CKLW1}		0.70	1.02	μs	*1
OSC ₁ "H" level pulse width (2)	t _{CKHW2}		3.13	4.55	μs	OSC ₁
OSC ₁ "L" level pulse width (2)	t _{CKLW2}		3.13	4.55	μs	*2
OSC ₁ "H" level pulse width (3)	t _{CKHW3}		21.8	31.4	μs	OSC ₁
OSC ₁ "L" level pulse width (3)	t _{CKLW3}		21.8	31.4	μs	*3

Note) Each timing is specified based on 20% and 80% of V_{DD}.

Note 1) Applied to the variable gradation mode / MON="0",PWM="0"

Note 2) Applied to the fixed gradation mode / MON="0",PWM="1"

Note 3) Applied to the B&W mode / MON="1"

NJU6824

- Reset input timing

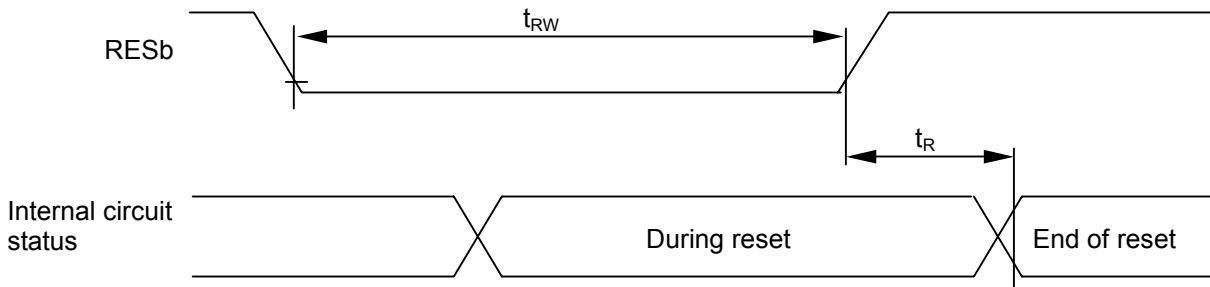

($V_{DD}=2.4$ to $3.3V$, $T_a=-30$ to $+85^{\circ}C$)

PARAMETER	SYMBOL	CONDITION	MIN.	MAX.	UNIT	Terminal
Reset time	t_R			1.0	μs	
RESb "L" level pulse width	t_{RW}		10.0		μs	RESb

($V_{DD}=1.7$ to $2.4V$, $T_a=-30$ to $+85^{\circ}C$)

PARAMETER	SYMBOL	CONDITION	MIN.	MAX.	UNIT	Terminal
Reset time	t_R			1.5	μs	
RESb "L" level pulse width	t_{RW}		10.0		μs	RESb

Note) Each timing is specified based on 20% and 80% of V_{DD} .

● Typical characteristic

PARAMETER	SYMBOL	MIN	TYP	MAX	UNIT
Basic delay time of gate	$T_a=+25^{\circ}\text{C}, V_{SS}=0\text{V}, V_{DD}=3.0\text{V}$		10		ns

● Input output terminal type

(a) Input circuit

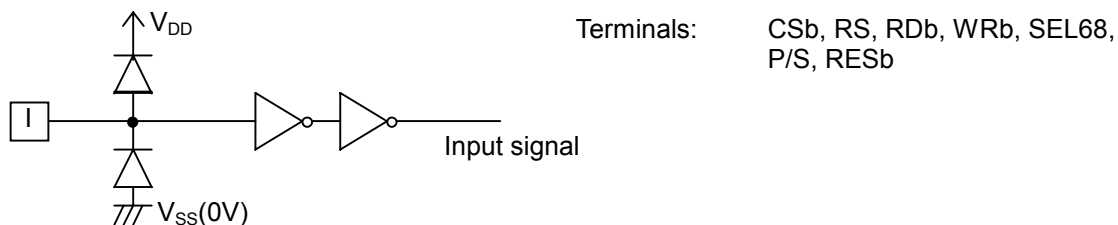

(b) Output circuit

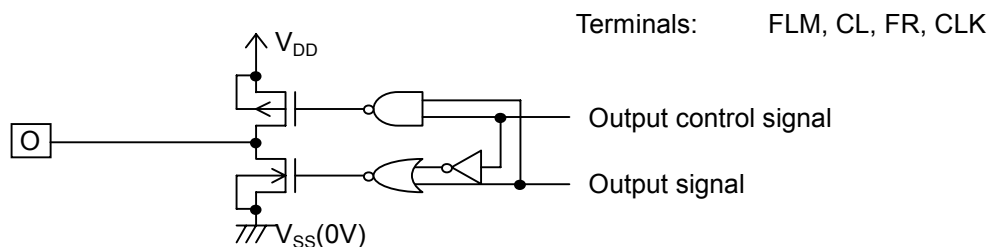

(c) Input/Output circuit

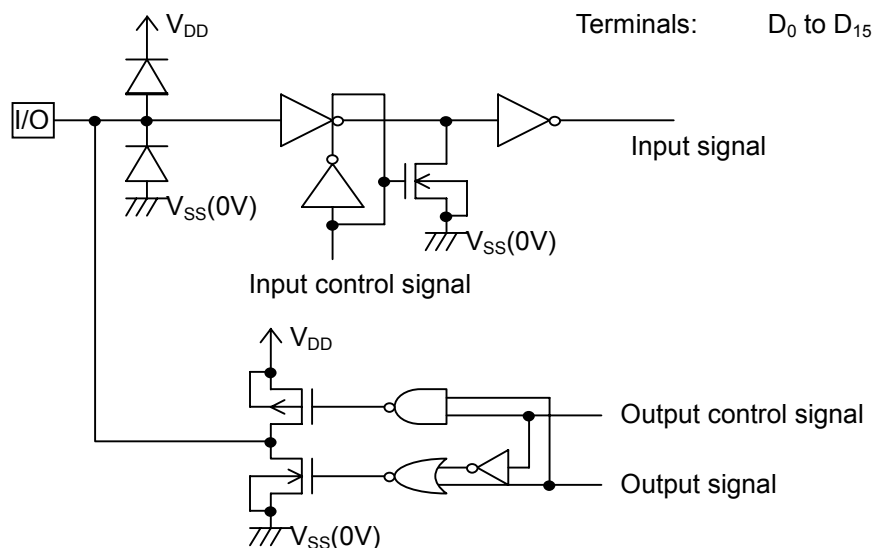

(d) Display output circuit

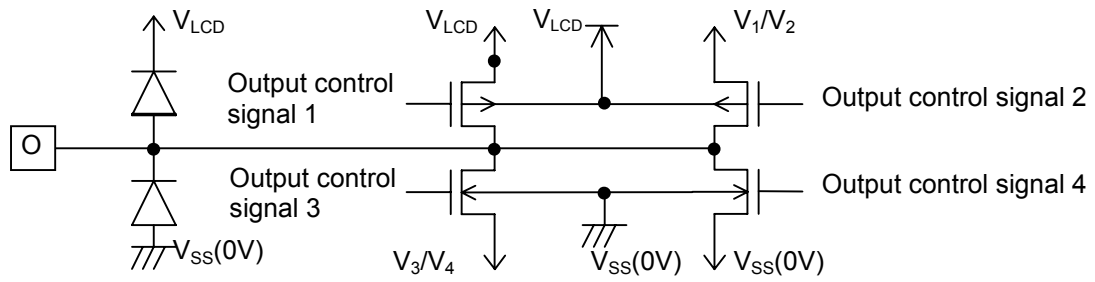

Terminals: SEGA₀ to SEGA₁₂₇
 SEGB₀ to SEGB₁₂₇
 SEGC₀ to SEGC₁₂₇
 COM₀ to COM₁₂₇
 SEGSA₀ to SEGSA₁
 SEGSB₀ to SEGSB₁
 SEGSC₀ to SEGSC₁

APPLICATION CIRCUIT EXAMPLES

(1) MPU Connections

80-type MPU interface

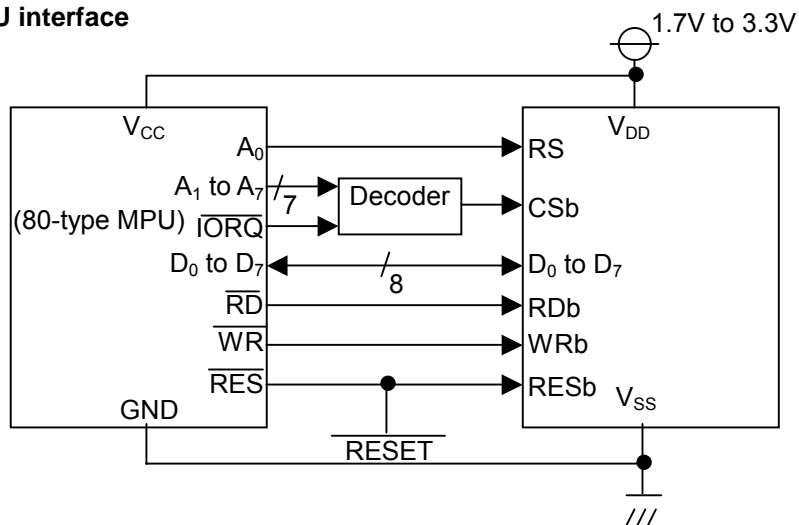

68-type MPU interface

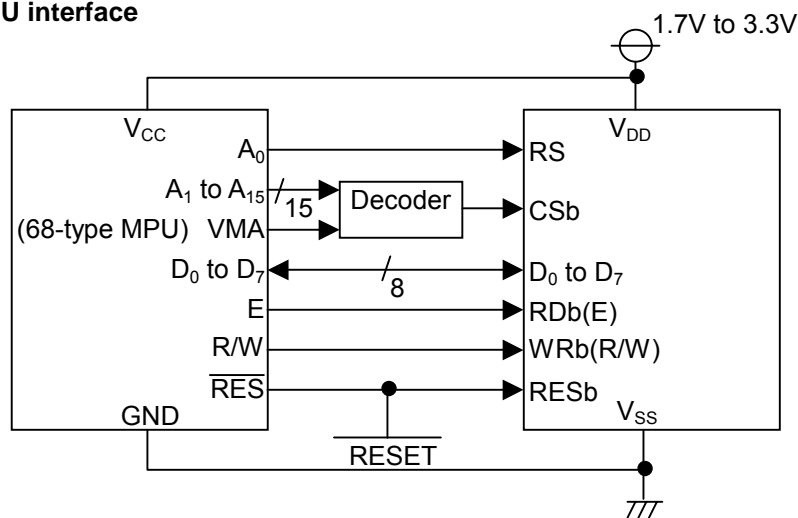

Serial interface

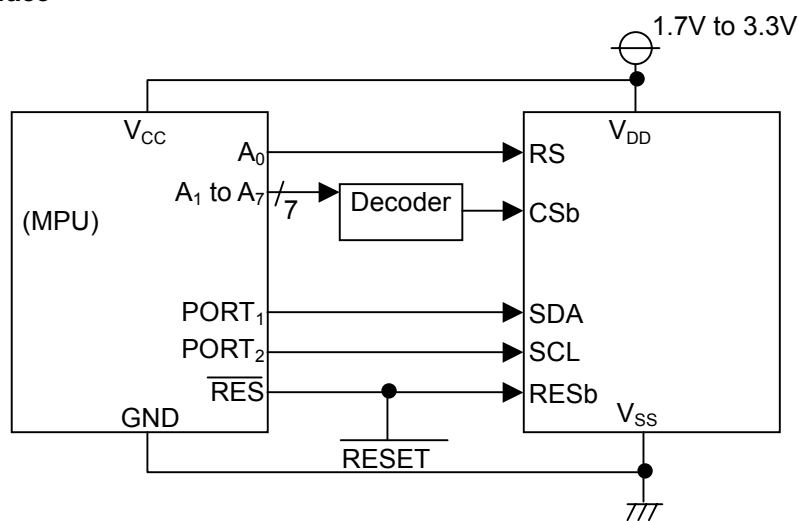

[CAUTION]

The specifications on this databook are only given for information, without any guarantee as regards either mistakes or omissions. The application circuits in this databook are described only to show representative usages of the product and not intended for the guarantee or permission of any right including the industrial rights.