

NLAS3799B, NLAS3799BL

Dual DPDT Ultra-Low R_{ON} Switch

The NLAS3799B is an ultra-low R_{ON} dual DPDT and a 0.5Ω R_{ON} analog switch. This device is designed for low operating voltage, high current switching of speaker output and earpiece for cellphone applications. It can switch a balanced stereo output. The NLAS3799B can handle a balanced microphone/speaker/ring-tone generator in a monophone mode. The device contains a break-before-make (BBM) feature.

Features

- Single Supply Operation
1.65 to 4.5 V V_{CC}
Function Directly from LiON Battery
- Maximum Breakdown Voltage: 5.5 V
- Low Static Power
- NLAS3799B Interfaces with 2.8 V Chipset
NLAS3799BL Interfaces with 1.8 V Chipset
- These are Pb-Free Devices*

Typical Applications

- Cell Phone Speaker/Microphone Switching
- Ringtone-Chip/Amplifier Switching
- Four Unbalanced (Single-Ended) Switches
- Stereo Balanced (Push-Pull) Switching

Important Information

- ESD Protection:
HBM (Human Body Model) > 8000 V
MM (Machine Model) > 400 V
- Continuous Current Rating Through each Switch ± 300 mA
- Conforms to: JEDEC MO-220, Issue H, Variation VEED-6
- Package: 1.8 x 2.6 x 0.75 mm WQFN-16 Pb-Free



ON Semiconductor®

<http://onsemi.com>

MARKING DIAGRAMS

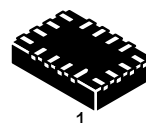

**WQFN-16
CASE 488AP**

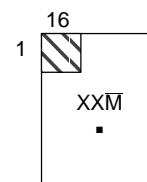

XX = Specific Device Code
AK = NLAS3799B
AL = NLAS3799BL
 \overline{M} = Date Code/Assembly Location
■ = Pb-Free Package

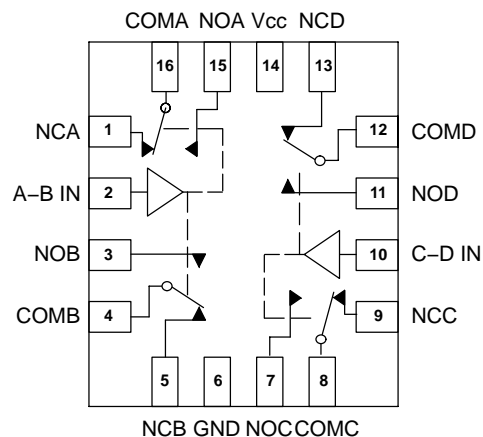

ORDERING INFORMATION

See detailed ordering and shipping information in the package dimensions section on page 10 of this data sheet.

*For additional information on our Pb-Free strategy and soldering details, please download the ON Semiconductor Soldering and Mounting Techniques Reference Manual, SOLDERRM/D.

NLAS3799B, NLAS3799BL

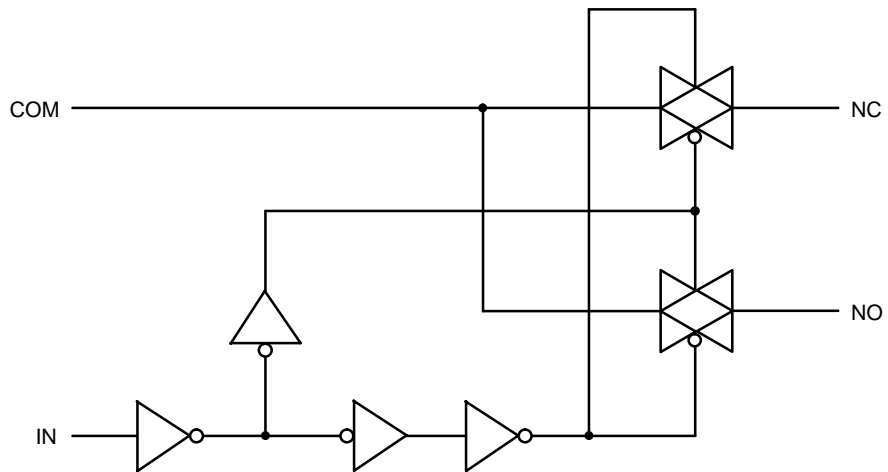

Figure 1. Input Equivalent Circuit

PIN DESCRIPTION

WQFN PIN #	Symbol	Name and Function
1, 3, 5, 7, 9, 11, 13, 15	NO A-D, NC A-D	Independent Channels
2, 10	A-B IN, C-D IN	Controls
4, 8, 12, 16	COM A-D	Common Channels
6	GND	Ground (V)
14	V _{CC}	Positive Supply Voltage

TRUTH TABLE

IN	NO	NC
H	ON	OFF*
L	OFF*	ON

*High impedance.

NLAS3799B, NLAS3799BL

MAXIMUM RATINGS

Symbol	Parameter	Value	Unit
V_{CC}	Positive DC Supply Voltage	-0.5 to +5.5	V
V_{IS}	Analog Input Voltage (V_{NO} , V_{NC} , or V_{COM})	$-0.5 \leq V_{IS} \leq V_{CC} + 0.5$	V
V_{IN}	Digital Select Input Voltage	$-0.5 \leq V_{IN} \leq +V_{CC}$	V
I_{anI1}	Continuous DC Current from COM to NC/NO	± 300	mA
$I_{anI-pk1}$	Peak Current from COM to NC/NO, 10 Duty Cycle (Note 1)	± 500	mA
I_{clmp}	Continuous DC Current into COM/NO/NC with Respect to V_{CC} or GND	± 100	mA

Stresses exceeding Maximum Ratings may damage the device. Maximum Ratings are stress ratings only. Functional operation above the Recommended Operating Conditions is not implied. Extended exposure to stresses above the Recommended Operating Conditions may affect device reliability.

1. Defined as 10% ON, 90% OFF Duty Cycle.

RECOMMENDED OPERATING CONDITIONS

Symbol	Parameter	Min	Max	Unit
V_{CC}	DC Supply Voltage	1.65	4.5	V
V_{IN}	Digital Select Input Voltage	GND	V_{CC}	V
V_{IS}	Analog Input Voltage (NC, NO, COM)	GND	V_{CC}	V
T_A	Operating Temperature Range	-40	+85	°C
t_r, t_f	Input Rise or Fall Time, IN $V_{CC} = 1.6\text{ V} - 2.7\text{ V}$ $V_{CC} = 3.0\text{ V} - 4.5\text{ V}$		20 10	ns/V

NLAS3799B, NLAS3799BL

NLAS3799B DC CHARACTERISTICS – DIGITAL SECTION (Voltages Referenced to GND)

Symbol	Parameter	Condition	V _{CC}	Guaranteed Limit		Unit
				25°C	-40°C to +85°C	
V _{IH}	Minimum High-Level Input Voltage, Select Inputs		3.0	1.4	1.4	V
			4.3	2.0	2.0	
V _{IL}	Maximum Low-Level Input Voltage, Select Inputs		3.0	0.5	0.5	V
			4.3	0.8	0.8	
I _{IN}	Maximum Input Leakage Current, Select Inputs	V _{IN} = V _{CC} or GND	4.3	±0.1	±1.0	μA
I _{OFF}	Power Off Leakage Current	V _{IN} = 4.5 V or GND	0	±0.5	±2.0	μA
I _{CC}	Maximum Quiescent Supply Current (Note 2)	Select and V _{IS} = V _{CC} or GND	1.65 to 4.5	±1.0	±2.0	μA

2. Guaranteed by design. Resistance measurements do not include test circuit or package resistance.

NLAS3799B DC ELECTRICAL CHARACTERISTICS – ANALOG SECTION

Symbol	Parameter	Condition	V _{CC}	Guaranteed Maximum Limit				Unit
				25°C		-40°C to +85°C		
				Min	Max	Min	Max	
R _{ON}	NC/NO On-Resistance (Note 3)	V _{IN} = V _{IL} or V _{IN} = V _{IH} V _{IS} = GND to V _{CC} I _{IN} = 100 mA	3.0		0.5		0.6	Ω
			4.3		0.4		0.5	
R _{FLAT}	NC/NO On-Resistance Flatness (Notes 3 and 4)	I _{COM} = 100 mA V _{IS} = 0 to V _{CC}	3.0		0.15		0.15	Ω
			4.3		0.15		0.15	
ΔR _{ON}	On-Resistance Match Between Channels (Notes 3 and 5)	V _{IS} = 1.5 V; I _{COM} = 100 mA V _{IS} = 2.2 V; I _{COM} = 100 mA	3.0		0.05		0.05	Ω
			4.3		0.05		0.05	
I _{NC(OFF)} I _{NO(OFF)}	NC or NO Off Leakage Current (Note 3)	V _{IN} = V _{IL} or V _{IH} V _{NO} or V _{NC} = 0.3 V V _{COM} = 4.0 V	4.3	-10	10	-100	100	nA
I _{COM(ON)}	COM ON Leakage Current (Note 3)	V _{IN} = V _{IL} or V _{IH} V _{NO} 0.3 V or 4.0 V with V _{NC} floating or V _{NC} 0.3 V or 4.0 V with V _{NO} floating V _{COM} = 0.3 V or 4.0 V	4.3	-10	10	-100	100	nA

3. Guaranteed by design. Resistance measurements do not include test circuit or package resistance.

4. Flatness is defined as the difference between the maximum and minimum value of On-resistance as measured over the specified analog signal ranges.

5. ΔR_{ON} = R_{ON(MAX)} – R_{ON(MIN)} between NCn or NOn.

NLAS3799B, NLAS3799BL

NLAS3799BL DC CHARACTERISTICS – DIGITAL SECTION (Voltages Referenced to GND)

Symbol	Parameter	Condition	V _{CC}	Guaranteed Limit		Unit
				25°C	-40 to +85°C	
V _{IH}	Minimum High-Level Input Voltage, Select Inputs		3.0	1.3	1.3	V
			4.3	1.6	1.6	
V _{IL}	Maximum Low-Level Input Voltage, Select Inputs		3.0	0.5	0.5	V
			4.3	0.6	0.6	
I _{IN}	Maximum Input Leakage Current, Select Inputs	V _{IN} = V _{CC} or GND	4.3	±0.1	±1.0	µA
I _{OFF}	Power Off Leakage Current	V _{IN} = 4.5 V or GND	0	±0.5	±2.0	µA
I _{CC}	Maximum Quiescent Supply Current (Note 6)	Select and V _{IS} = V _{CC} or GND	1.65 to 4.3	±40	±45	µA

6. Guaranteed by design. Resistance measurements do not include test circuit or package resistance.

NLAS3799BL DC ELECTRICAL CHARACTERISTICS – ANALOG SECTION

Symbol	Parameter	Condition	V _{CC}	Guaranteed Maximum Limit				Unit
				25°C		-40°C to +85°C		
				Min	Max	Min	Max	
R _{ON}	NC/NO On-Resistance (Note 7)	V _{IN} = V _{IL} or V _{IN} = V _{IH} V _{IS} = GND to V _{CC} I _{IN} = 100 mA	3.0		0.5		0.6	Ω
			4.3		0.4		0.5	
R _{FLAT}	NC/NO On-Resistance Flatness (Notes 7 and 8)	I _{COM} = 100 mA V _{IS} = 0 to V _{CC}	3.0		0.15		0.15	Ω
			4.3		0.15		0.15	
ΔR _{ON}	On-Resistance Match Between Channels (Notes 7 and 9)	V _{IS} = 1.5 V; I _{COM} = 100 mA V _{IS} = 2.2 V; I _{COM} = 100 mA	3.0		0.05		0.05	Ω
			4.3		0.05		0.05	
I _{NC(OFF)} I _{NO(OFF)}	NC or NO Off Leakage Current (Note 7)	V _{IN} = V _{IL} or V _{IH} V _{NO} or V _{NC} = 0.3 V V _{COM} = 4.0 V	4.3	-10	10	-100	100	nA
I _{COM(ON)}	COM ON Leakage Current (Note 7)	V _{IN} = V _{IL} or V _{IH} V _{NO} 0.3 V or 4.0 V with V _{NC} floating or V _{NC} 0.3 V or 4.0 V with V _{NO} floating V _{COM} = 0.3 V or 4.0 V	4.3	-10	10	-100	100	nA

7. Guaranteed by design. Resistance measurements do not include test circuit or package resistance.

8. Flatness is defined as the difference between the maximum and minimum value of On-resistance as measured over the specified analog signal ranges.

9. ΔR_{ON} = R_{ON(MAX)} – R_{ON(MIN)} between NC1 and NC2 or between NO1 and NO2.

NLAS3799B, NLAS3799BL

NLAS3799B/NLAS3799BL AC ELECTRICAL CHARACTERISTICS (Input $t_r = t_f = 3.0$ ns)

Symbol	Parameter	Test Conditions	V_{CC} (V)	V_{IS} (V)	Guaranteed Maximum Limit					Unit
					25°C			-40°C to +85°C		
					Min	Typ*	Max	Min	Max	
t_{ON}	Turn-On Time	$R_L = 50 \Omega$, $C_L = 35$ pF (Figures 3 and 4)	2.3 – 4.3	1.5			50		60	ns
t_{OFF}	Turn-Off Time	$R_L = 50 \Omega$, $C_L = 35$ pF (Figures 3 and 4)	2.3 – 4.3	1.5			30		40	ns
t_{BBM}	Minimum Break-Before-Make Time	$V_{IS} = 3.0$ $R_L = 50 \Omega$, $C_L = 35$ pF (Figure 2)	3.0	1.5	2	15				ns

		Typical @ 25, $V_{CC} = 3.6$ V	
C_{IN}	Control Pin Input Capacitance	3.0	pF
C_{SN}	SN Port Capacitance	72	pF
C_D	D Port Capacitance When Switch is Enabled	220	pF

*Typical Characteristics are at 25°C.

ADDITIONAL APPLICATION CHARACTERISTICS (Voltages Referenced to GND Unless Noted)

Symbol	Parameter	Condition	V_{CC} (V)	25°C	Unit
				Typical	
BW	Maximum On-Channel -3 dB Bandwidth or Minimum Frequency Response (Figure 9)	V_{IN} centered between V_{CC} and GND (Figure 5)	1.65 – 4.5	19	MHz
V_{ONL}	Maximum Feed-through On Loss	$V_{IN} = 0$ dBm @ 100 kHz to 50 MHz V_{IN} centered between V_{CC} and GND (Figure 5)	1.65 – 4.5	-0.06	dB
V_{ISO}	Off-Channel Isolation	$f = 100$ kHz; $V_{IS} = 1$ V RMS; $C_L = 5.0$ pF V_{IN} centered between V_{CC} and GND (Figure 5)	1.65 – 4.5	-69	dB
Q	Charge Injection Select Input to Common I/O (Figure 8)	$V_{IN} = V_{CC}$ to GND, $R_{IS} = 0 \Omega$, $C_L = 1.0$ nF $Q = C_L \times \Delta V_{OUT}$ (Figure 6)	1.65 – 4.5	51	pC
THD	Total Harmonic Distortion THD + Noise (Figure 7)	$F_{IS} = 20$ Hz to 20 kHz, $R_L = R_{gen} = 600 \Omega$, $C_L = 50$ pF $V_{IS} = 2$ V _{PP}	4.3	0.042	%
VCT	Channel-to-Channel Crosstalk (Figure 10)	$f = 100$ kHz; $V_{IS} = 1.0$ V RMS, $C_L = 5.0$ pF, $R_L = 50 \Omega$ V_{IN} centered between V_{CC} and GND (Figure 5)	1.65 – 4.5	-90	dB

10. Off-Channel Isolation = $20 \log_{10} (V_{COM}/V_{NO})$, V_{COM} = output, V_{NO} = input to off switch.

NLAS3799B, NLAS3799BL

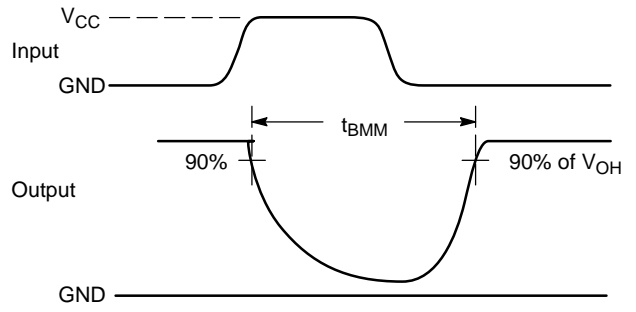
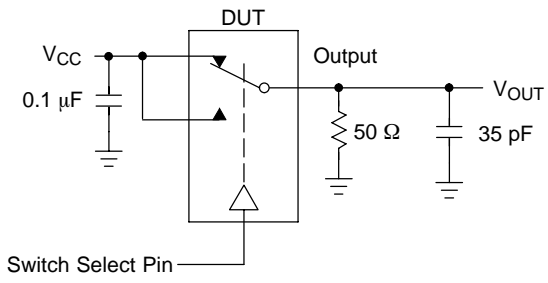

Figure 2. t_{BMM} (Time Break-Before-Make)

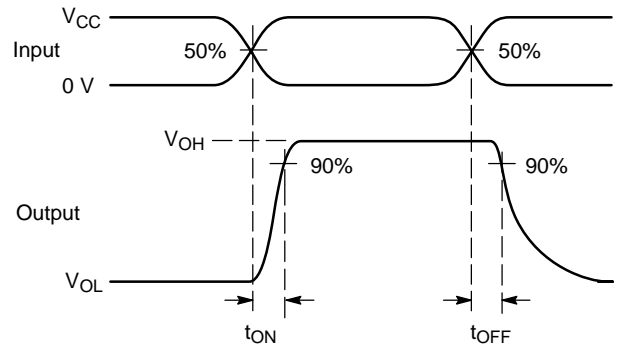
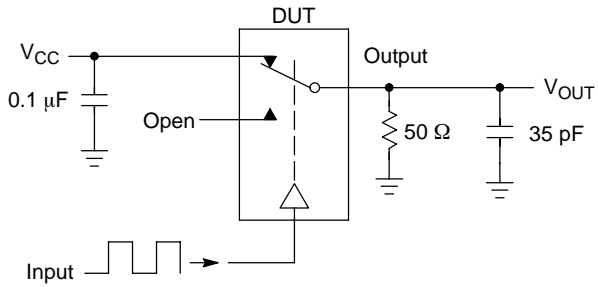

Figure 3. t_{ON}/t_{OFF}

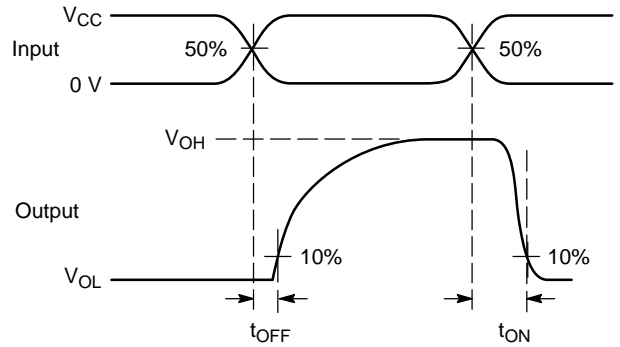
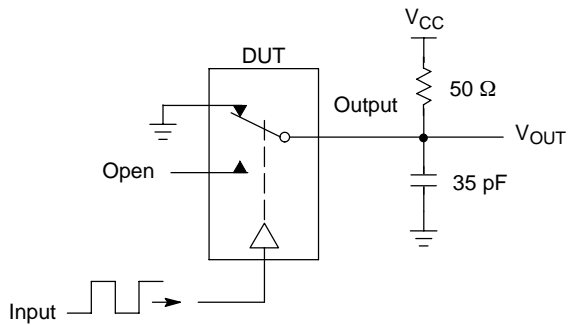
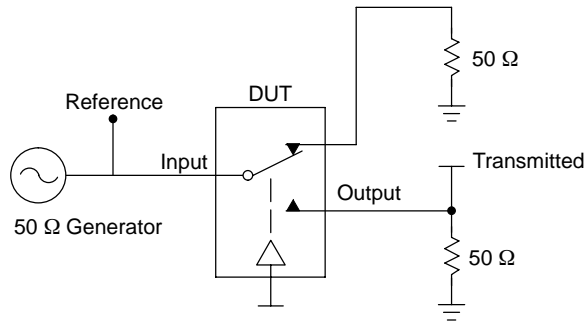

Figure 4. t_{ON}/t_{OFF}

NLAS3799B, NLAS3799BL



Channel switch control/s test socket is normalized. Off isolation is measured across an off channel. On loss is the bandwidth of an On switch. V_{ISO} , Bandwidth and V_{ONL} are independent of the input signal direction.

$$V_{ISO} = \text{Off Channel Isolation} = 20 \text{ Log} \left(\frac{V_{OUT}}{V_{IN}} \right) \text{ for } V_{IN} \text{ at } 100 \text{ kHz}$$

$$V_{ONL} = \text{On Channel Loss} = 20 \text{ Log} \left(\frac{V_{OUT}}{V_{IN}} \right) \text{ for } V_{IN} \text{ at } 100 \text{ kHz to } 50 \text{ MHz}$$

Bandwidth (BW) = the frequency 3 dB below V_{ONL}

V_{CT} = Use V_{ISO} setup and test to all other switch analog input/outputs terminated with 50 Ω

Figure 5. Off Channel Isolation/On Channel Loss (BW)/Crosstalk (On Channel to Off Channel)/ V_{ONL}

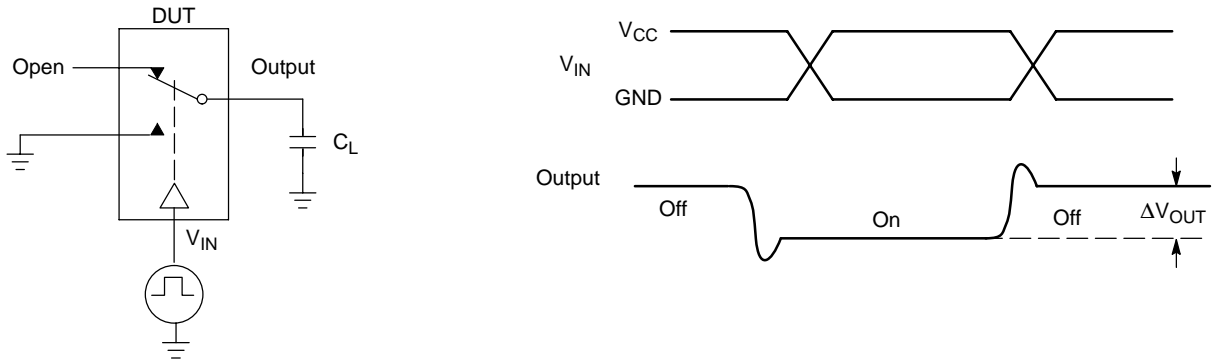

Figure 6. Charge Injection: (Q)

NLAS3799B, NLAS3799BL

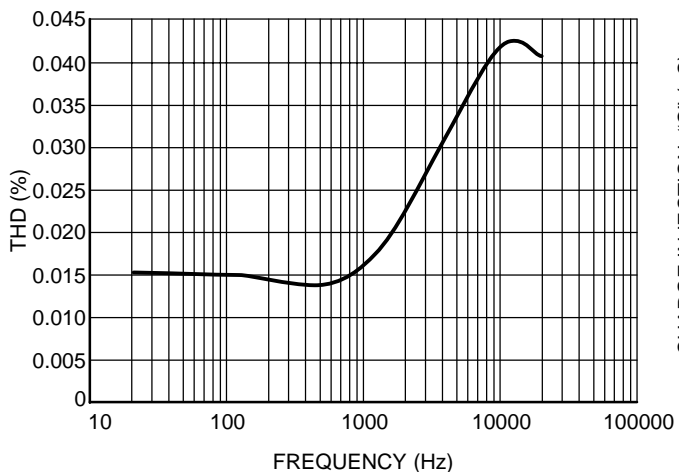

Figure 7. Total Harmonic Distortion vs. Frequency

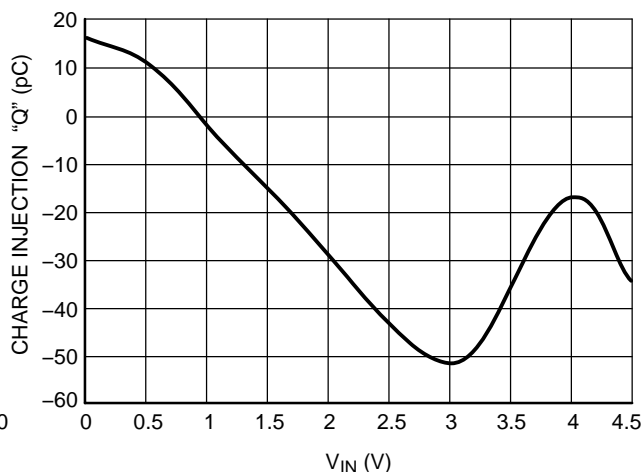

Figure 8. Charge Injection @ $0\text{ V} < V_{CC} < 4.5\text{ V}$

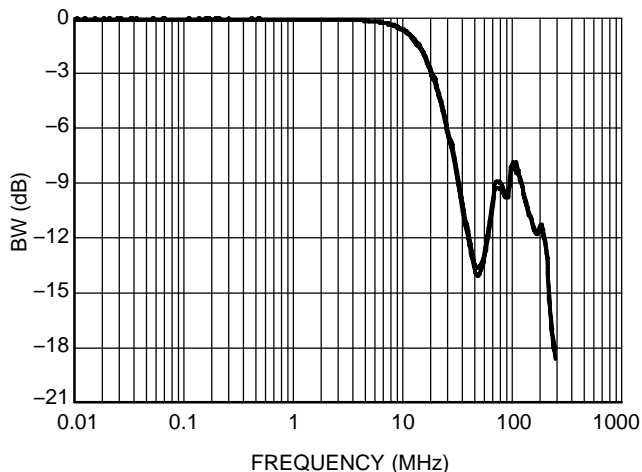

Figure 9. Bandwidth vs. Frequency

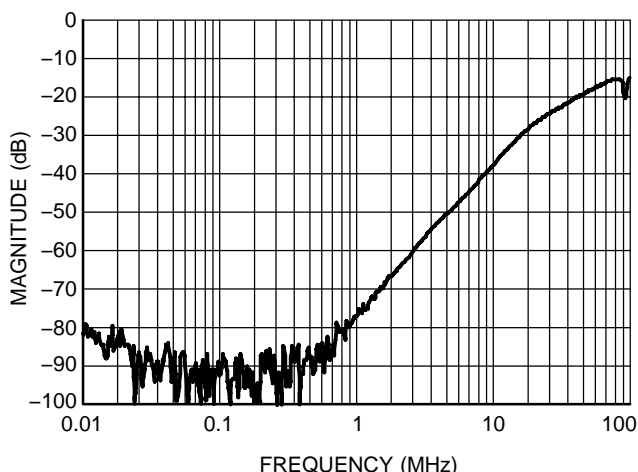

Figure 10. Cross-Talk vs. Frequency

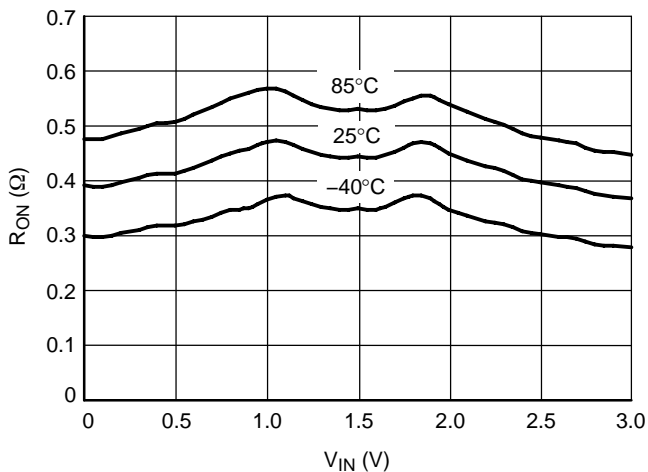

Figure 11. R_{ON} vs. V_{IN} vs. Temperature @ $V_{CC} = 3.0\text{ V}$

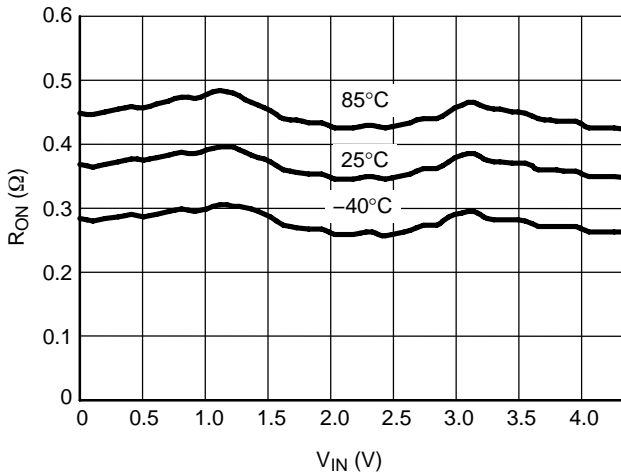

Figure 12. R_{ON} vs. V_{IN} vs. Temperature @ $V_{CC} = 4.3\text{ V}$

NLAS3799B, NLAS3799BL

DEVICE ORDERING INFORMATION

Device Order Number	Device Nomenclature					Package Type	Tape & Reel Size†
	Circuit Indicator	Technology	Device Function	Package Suffix	Tape & Reel Suffix		
NLAS3799BMNR2G	NL	AS	3799B	MN	R2	WQFN (Pb-Free)	3000 / Tape & Reel
NLAS3799BLMNR2G	NL	AS	3799BL	MN	R2	WQFN (Pb-Free)	3000 / Tape & Reel

†For information on tape and reel specifications, including part orientation and tape sizes, please refer to our Tape and Reel Packaging Specifications Brochure, BRD8011/D.

NLAS3799B, NLAS3799BL

PACKAGE DIMENSIONS

WQFN16 (1.8x2.6x0.4P)
CASE 488AP-01
ISSUE A

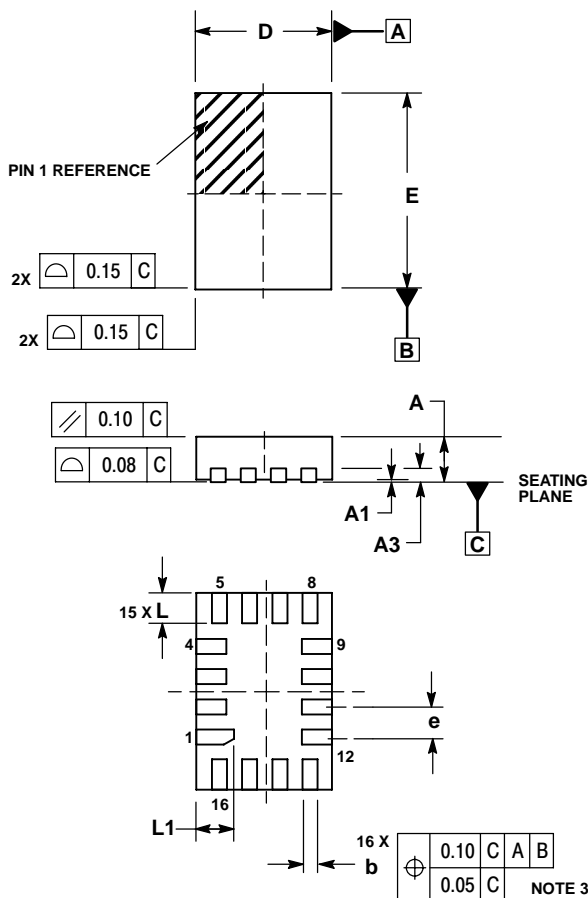

NOTES:

1. DIMENSIONING AND TOLERANCING PER ASME Y14.5M, 1994.
2. CONTROLLING DIMENSION: MILLIMETERS
3. DIMENSION b APPLIES TO PLATED TERMINAL AND IS MEASURED BETWEEN 0.25 AND 0.30 MM FROM TERMINAL.
4. COPLANARITY APPLIES TO THE EXPOSED PAD AS WELL AS THE TERMINALS.
5. EXPOSED PADS CONNECTED TO DIE FLAG. USED AS TEST CONTACTS.

DIM	MILLIMETERS	
	MIN	MAX
A	0.70	0.80
A1	0.00	0.050
A3	0.20	REF
b	0.15	0.25
D	1.80	BSC
E	2.60	BSC
e	0.40	BSC
L	0.30	0.50
L1	0.40	0.60

MOUNTING FOOTPRINT

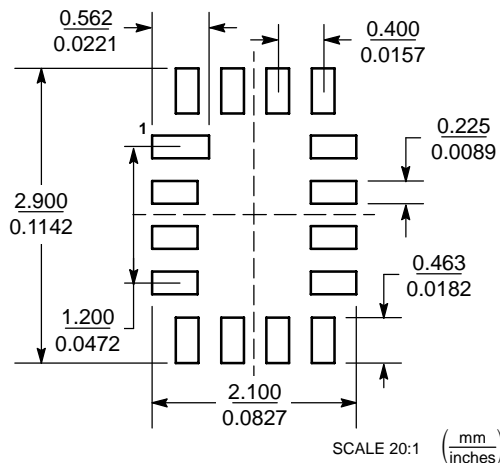

ON Semiconductor and are registered trademarks of Semiconductor Components Industries, LLC (SCILLC). SCILLC reserves the right to make changes without further notice to any products herein. SCILLC makes no warranty, representation or guarantee regarding the suitability of its products for any particular purpose, nor does SCILLC assume any liability arising out of the application or use of any product or circuit, and specifically disclaims any and all liability, including without limitation special, consequential or incidental damages. "Typical" parameters which may be provided in SCILLC data sheets and/or specifications can and do vary in different applications and actual performance may vary over time. All operating parameters, including "Typicals" must be validated for each customer application by customer's technical experts. SCILLC does not convey any license under its patent rights nor the rights of others. SCILLC products are not designed, intended, or authorized for use as components in systems intended for surgical implant into the body, or other applications intended to support or sustain life, or for any other application in which the failure of the SCILLC product could create a situation where personal injury or death may occur. Should Buyer purchase or use SCILLC products for any such unintended or unauthorized application, Buyer shall indemnify and hold SCILLC and its officers, employees, subsidiaries, affiliates, and distributors harmless against all claims, costs, damages, and expenses, and reasonable attorney fees arising out of, directly or indirectly, any claim of personal injury or death associated with such unintended or unauthorized use, even if such claim alleges that SCILLC was negligent regarding the design or manufacture of the part. SCILLC is an Equal Opportunity/Affirmative Action Employer. This literature is subject to all applicable copyright laws and is not for resale in any manner.

PUBLICATION ORDERING INFORMATION

LITERATURE FULFILLMENT:
Literature Distribution Center for ON Semiconductor
P.O. Box 61312, Phoenix, Arizona 85082-1312 USA
Phone: 480-829-7710 or 800-344-3860 Toll Free USA/Canada
Fax: 480-829-7709 or 800-344-3867 Toll Free USA/Canada
Email: orderlit@onsemi.com

N. American Technical Support: 800-282-9855 Toll Free
USA/Canada

Japan: ON Semiconductor, Japan Customer Focus Center
2-9-1 Kamimeguro, Meguro-ku, Tokyo, Japan 153-0051
Phone: 81-3-5773-3850

ON Semiconductor Website: <http://onsemi.com>

Order Literature: <http://www.onsemi.com/litorder>

For additional information, please contact your local Sales Representative.