

ROITHNER LASERTECHNIK

A-1040 WIEN, FLEISCHMANNGASSE 9
 TEL: +43 -1- 586 52 43 FAX: +43 -1- 586 41 43
 e-mail: rlt@mcb.at http://www.roithner.mcb.at

NSHU550E TECHNICAL DATA



UV LED

Peak Wavelength: 370 nm typ.
 Output power: 1 mW, cw
 Package: TO-46, flat window

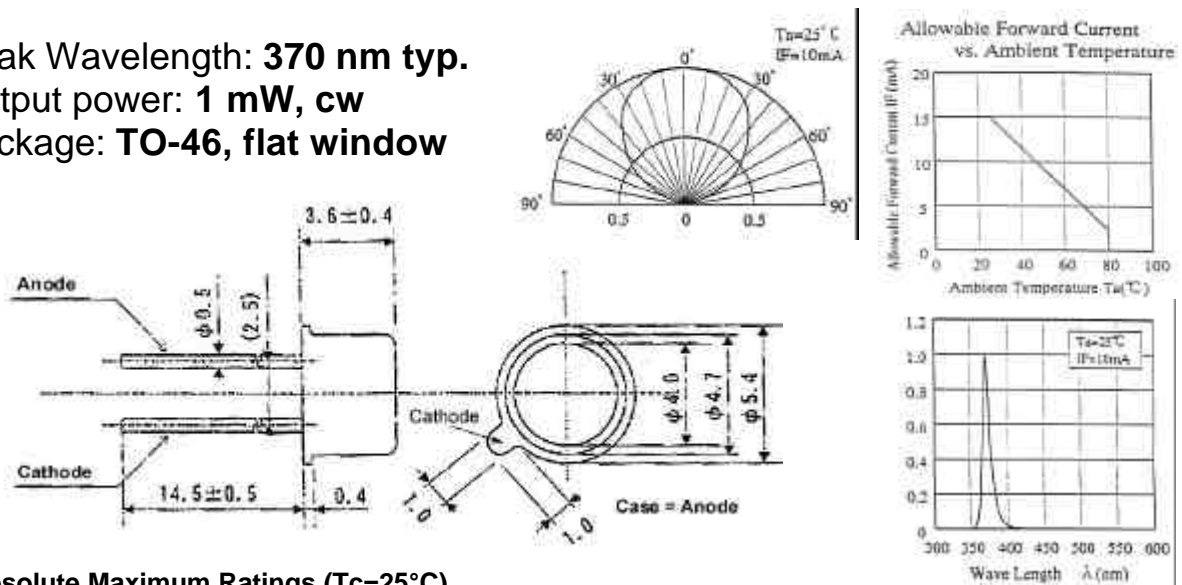

Absolute Maximum Ratings (Tc=25°C)

CHARACTERISTIC	SYMBOL	RATING	UNIT
DC Forward Current	I_F	15	mA
Pulse Forward Current *)	I_{FP}	30	mA
Allowable Reverse Current	I_R	85	mA
Power Dissipation	P_D	60	mW
Operating Temperature	T_{OP}	-30 .. +80	°C
Storage Temperature	T_{STG}	-40 .. +100	°C

*) Pulse width \leq 10 ms, duty cycle \leq 0.1

Optical-Electrical Characteristics (Tc = 25°C)

CHARACTERISTIC	SYMBOL	TEST CONDITION	MIN	TYP	MAX	UNIT
DC Forward Voltage	V_F	$I_F = 10 \text{ mA}$	-	3.9	-	V
Optical Power	P_O	$I_F = 10 \text{ mA}$	-	1	-	mW
Peak Wavelength	λ_P	$I_F = 10 \text{ mA}$	-	370	-	nm
Spectrum Half Width	$\Delta\lambda$	$I_F = 10 \text{ mA}$	-	12	-	nm
Divergence	θ	$I_F = 10 \text{ mA}$	-	110	-	°

⚠ CAUTION

- The UV LED during operation radiates intense UV light.
- Do not look directly into the UV light during operation of device. This can be harmful to the eyes even for brief period due to the intense UV light.
- If viewing the UV light is necessary, please use UV filtered glasses to avoid damage by the UV light.
- If the UV LED in your product might be viewed directly, please affix caution label to your product to that effect.

Avoid direct eye exposure to UV light.
Keep out of reach of children.