

Version : 1.1

TECHNICAL SPECIFICATION

MODEL NO. : PW090XS2

Customer's Confirmation

Customer \_\_\_\_\_

Date \_\_\_\_\_

By \_\_\_\_\_

PVI's Confirmation

Confirmed By \_\_\_\_\_

Prepared By \_\_\_\_\_

**PRIME VIEW INTERNATIONAL CO.,LTD.**

3,LI SHIN RD. 1,SCIENCE-BASED INDUSTRIAL  
PARK,HSINCHU,TAIWAN,R.O.C.

<http://www.pvi.com.tw>

Date : Oct. 08 , 2004

This technical specification is subject to change without notice.  
Please return 1 copy with your signature on this page for approval.

The information contained herein is the exclusive property of Prime View International Co., Ltd. and shall not be distributed, reproduced, or disclosed in whole or in part without prior written permission of Prime View International Co., Ltd. PAGE:1

# TECHNICAL SPECIFICATION

## CONTENTS

<i>NO.</i>	<i>ITEM</i>	<i>PAGE</i>
-	Cover	1
-	Contents	2
1	Application	3
2	Features	3
3	Mechanical Specifications	3
4	Mechanical Drawing of TFT-LCD module	4
5	Input / Output Terminals	5
6	Pixel Arrangement and input connector pin NO.	6
7	Absolute Maximum Ratings	7
8	Electrical Characteristics	7
9	Power Sequence	17
10	Optical Characteristics	17
11	Handling Cautions	21
12	Reliability Test	22
13	Indication of Lot Number Label	22
14	Block Diagram	23
15	Packing	24
-	Revision History	25

## 1. Application

This technical specification applies to 9.0" color TFT-LCD module, PW090XS2. The applications of the panel are car TV, portable DVD, GPS, multimedia applications and others AV system.

## 2. Features

- . Pixel in stripe configuration
- . Compatible with NTSC and PAL system
- . Slim and compact
- . High Brightness
- . Wide Viewing Angle
- . Up / Down and Left / Right Image Reversion
- . Support Multi Video Display Mode  
(With PVI timing controller : PVI-1004D)

## 3. Mechanical Specifications

<b>Parameter</b>	<b>Specifications</b>	<b>Unit</b>
Screen Size	9.0 (16 : 8.3 diagonal)	Inch
Display Format	1920 (H)×220 (V)	Dot
Active Area	202.56 (H)×105.27 (V)	mm
Dot Pitch	0.1055 (H)×0.4785 (V)	mm
Pixel Configuration	Stripe	
Outline Dimension	219.4 (W)×120.8 (H)×6.9 (D) (typ.)	mm
Surface Treatment	Anti-Glare + WV film	
Weight	270±3	g

**4. Mechanical Drawing of TFT-LCD Module**

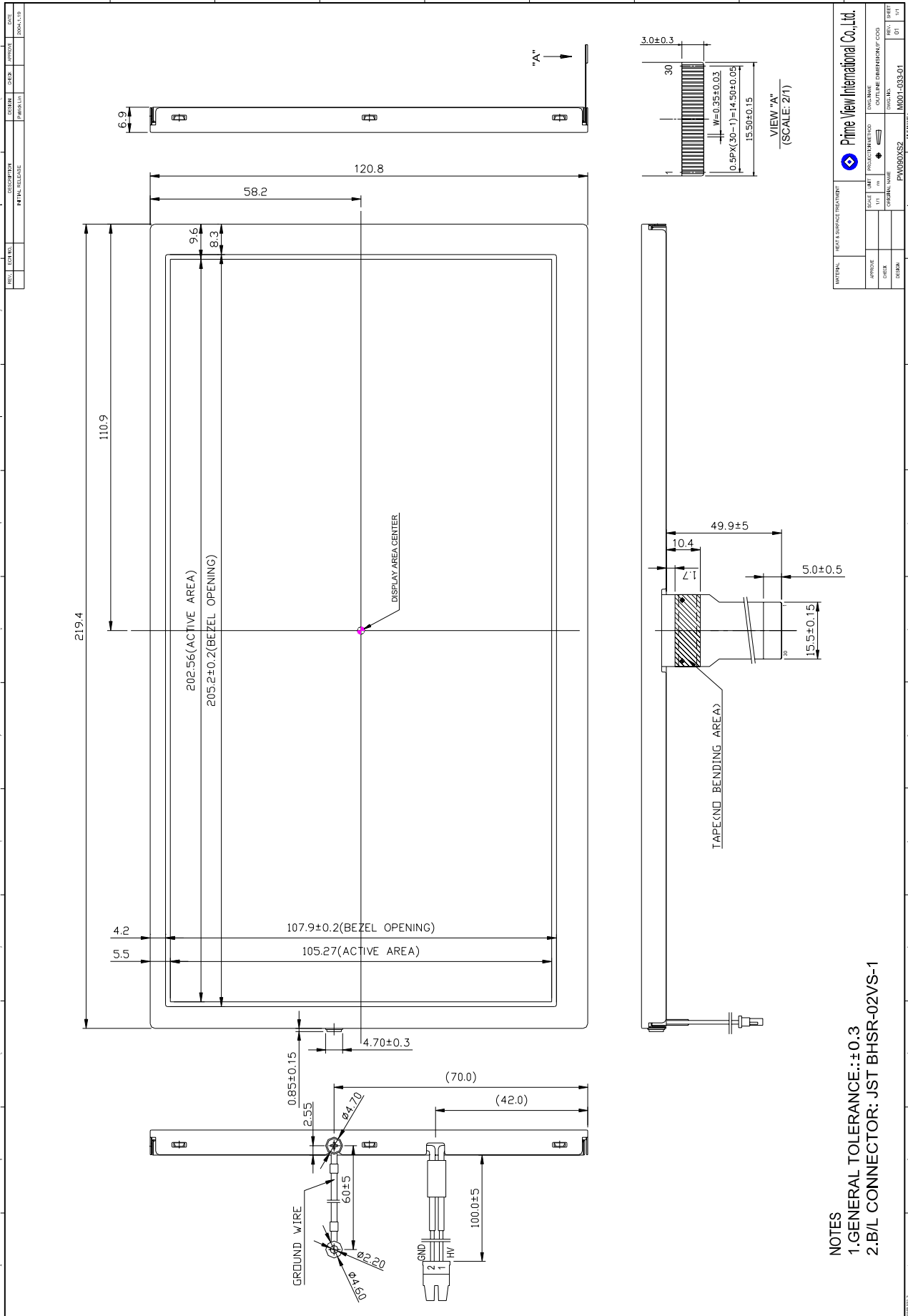

MATERIAL		HEAT & SURFACE TREATMENT		Prime View International Co., Ltd.	
APPROVE	DESIGN	PROCESSING	INSPECTION	DATE	REV.
CHIEF	IN	UNIT	IN	OUTLINE ENGINEERING CODE	01
DELTA	ORIGINAL NAME	PRODUCT NAME	TOUCH NO.	MODEL CODE	01
	PW090XS2			M001-033-01	

- NOTES**
- 1.GENERAL TOLERANCE:±0.3
  - 2.B/L CONNECTOR: JST BHSR-02VS-1

**5. Input / Output Terminals**

LCD Module Connector  
 FPC Down Connect , 30 Pins , Pitch : 0.5 mm

Pin No	Symbol	I/O	Description	Remark
1	GND	-	Ground for logic circuit	
2	V <sub>CC</sub>	I	Supply voltage of logic control circuit for gate driver	Note 5-3
3	NC	-	No connection	
4	V <sub>EE</sub>	I	Negative power for gate driver	Note 5-4
5	NC	-	No connection	
6	V <sub>GH</sub>	I	Positive power for gate driver	Note 5-5
7	NC	-	No connection	
8	STVD	I/O	Vertical start pulse	Note 5-1
9	STVU	I/O	Vertical start pulse	
10	CKV	I	Shift clock for gate driver	
11	U/D	I	Up / Down Control for gate driver	Note 5-1
12	OE3	I	Output enable for gate driver	
13	OE2	I	Output enable for gate driver	
14	OE1	I	Output enable for gate driver	
15	V <sub>COM</sub>	I	Common electrode voltage	
16	STHL	I/O	Start pulse for source driver	Note 5-2
17	V <sub>SS2</sub>	-	Ground for analog circuit	
18	V <sub>R</sub>	I	Video Input R	
19	V <sub>G</sub>	I	Video Input G	
20	V <sub>B</sub>	I	Video Input B	
21	V <sub>SS1</sub>	-	Ground for digital circuit	
22	V <sub>DD2</sub>	I	Supply power for analog circuit	Note 5-6
23	CPH1	I	Sampling and shift clock for source driver	
24	CPH2	I	Sampling and shift clock for source driver	
25	CPH3	I	Sampling and shift clock for source driver	
26	V <sub>DD1</sub>	I	Supply power for digital circuit	Note 5-7
27	R/L	I	Left / Right Control for source driver	Note 5-2
28	NC	I	No Connection	
29	OEH	I	Output enable for source driver	
30	STHR	I/O	Start pulse for source driver	Note 5-2

**Note 5-1**

U/D	STVD	STVU	scanning direction
V <sub>CC</sub>	Input	output	down to up
GND	output	input	up to down

**Note 5-2**

R/L	STHL	STHR	scanning direction
V <sub>CC</sub>	output	input	left to right
GND	input	output	right to left

The definitions of Note 5-1,5-2

U/D(PIN 11)=Low R/L(PIN 27)=High

U/D(PIN 11)=High R/L(PIN 27)=Low

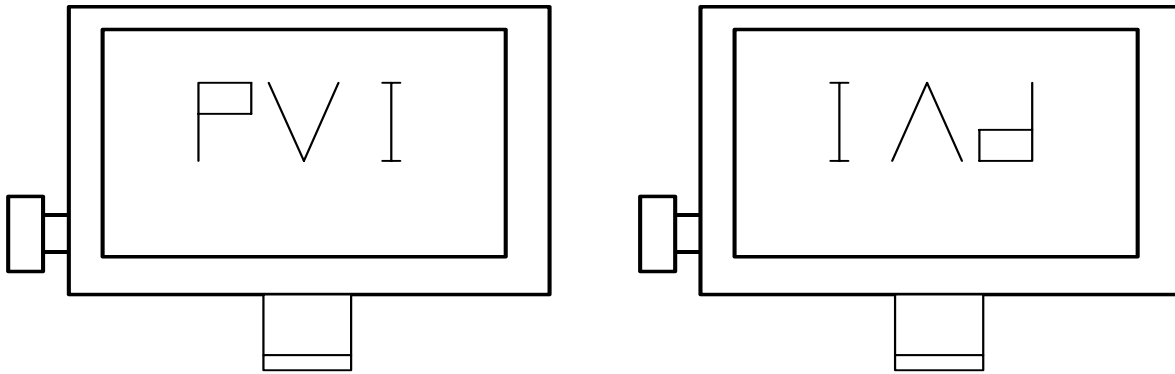

Note 5-3 :  $V_{CC}$  TYP. = +3.3V

Note 5-4 :  $V_{EE}$  TYP. = -12V

Note 5-5 :  $V_{GH}$  TYP. = +17V

Note 5-6 :  $V_{DD2}$  TYP. = +5V

Note 5-7 :  $V_{DD1}$  TYP. = +3.3V

6. Pixel Arrangement and input connector pin NO.

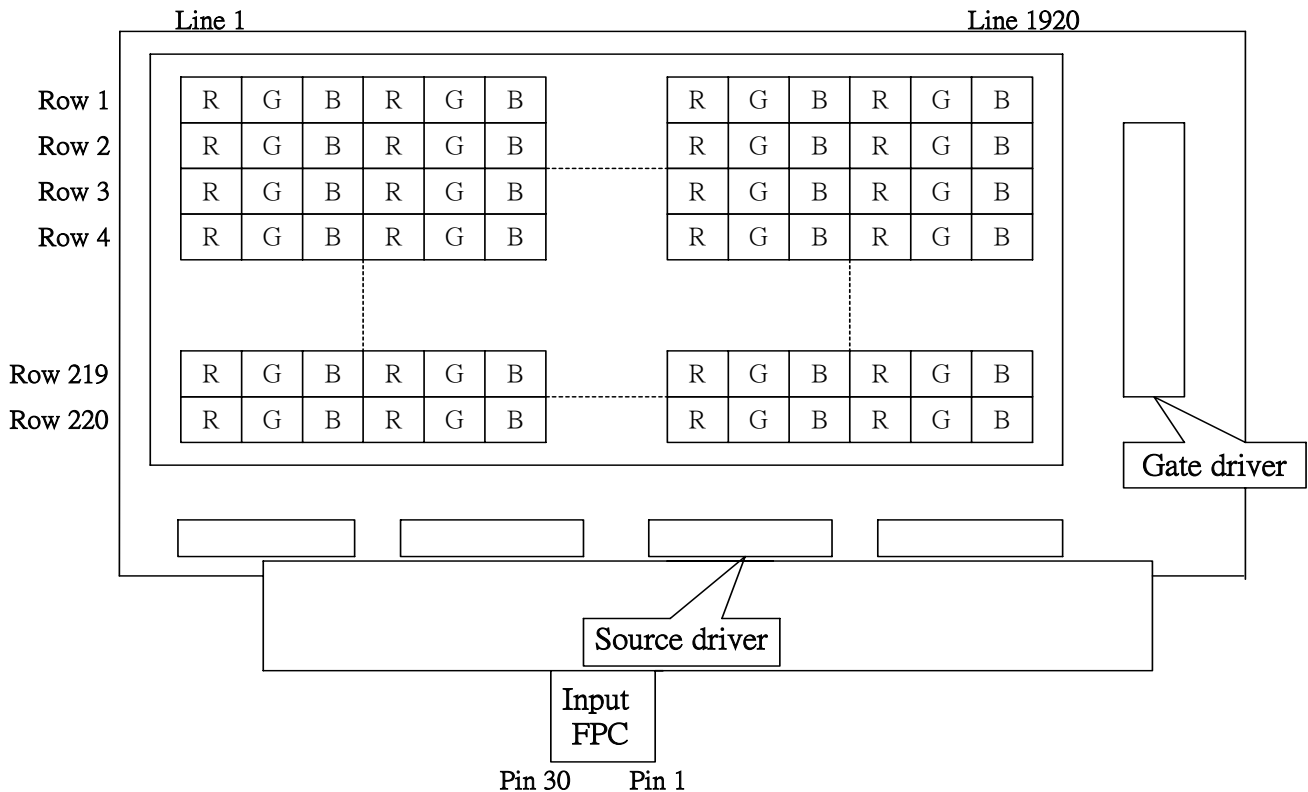

**7. Absolute Maximum Ratings**

The followings are maximum values , which if exceeded, may cause faulty operation or damage to the unit.

Parameter	Symbol	MIN.	MAX.	Unit	Remark
Supply Voltage For Source Driver	$V_{DD2}$	-0.3	+5.8	V	
	$V_{DD1}$	-0.3	+7.0	V	
Supply Voltage For Gate Driver	$V_{CC}$	-0.3	+6.0	V	
	$V_{GH}-V_{EE}$	-0.3	+40.0	V	
	H Level $V_{GH}$	-0.3	+25.0	V	
	L Level $V_{EE}$	-16	+0.3	V	
Analog Signal Input Level	$V_R, V_G, V_B$	-0.2	$V_{DD1}+0.2$	V	Note 7-1
Storage Temperature		-30	+80	°C	
Operation Temperature		-20	+80	°C	Note 7-2

Notes 7-1 : Analog Input Voltage means  $V_R, V_G, V_B$ .

Notes 7-2 : Optical characteristics shown in Table 10-1 are measured under  $T_a=+25^{\circ}\text{C}$ .

**8. Electrical Characteristics**
**8-1) Recommended Driving condition for TFT-LCD panel**

Parameter		Symbol	MIN.	Typ.	MAX.	Unit	Remark
Supply Voltage For Source Driver	Analog	$V_{DD2}$	+4.5	+5.0	+5.5	V	
	Logic	$V_{DD1}$	+3.0	+3.3	+3.6	V	
Supply Voltage For Gate Driver	H level	$V_{GH}$	+15	+17	+19	V	
	L level	$V_{EE\ DC}$	-13.0	-12	-10.5	V	DC Component of $V_{EE}$
		$V_{EE\ AC}$		+6.0		$V_{P-P}$	AC Component of $V_{EE}$
	Logic	$V_{CC}$	+3.0	+3.3	+3.6	V	
Analog Signal input Level	Amplitud		+0.3		$V_{CC}-0.3$	V	
Digital input voltage	H level	$V_{IH}$	$0.7 V_{DD1}$	-	$V_{DD1}$	V	
	L level	$V_{IL}$	-0.3	-	$0.3 V_{DD1}$	V	
Digital output voltage	H level	$V_{OH}$	$0.7 V_{DD1}$	-	$V_{DD1}$	V	
	L level	$V_{OL}$	-0.3	-	$0.3 V_{DD1}$	V	
$V_{COM}$		$V_{COM\ AC}$	-	+6.0	-	$V_{P-P}$	AC Component of $V_{COM}$
		$V_{COM\ DC}$	1.5	1.7	1.9	V	DC Component of $V_{COM}$ Note 8-1

Note 8-1 : PVI strongly suggests that the  $V_{COM\ DC}$  level shall be adjustable , and the adjustable level range is  $1.7V\pm 1V$  , every module's  $V_{COM\ DC}$  level shall be carefully adjusted to show a best image performance.

**8-2) Recommended driving condition for back light**

Ta= 25 °C

Parameter	Symbol	Min.	Typ.	Max.	Unit	Remark
Lamp voltage	$V_L$	589	654	720	Vrms	$I_L=6mA$
Lamp current	$I_L$	3	6	8	mA	Note 8-2
Lamp frequency	$P_L$	40	55	80	KHz	Note 8-3
Kick-off voltage(25°C) (Reference Value)	$V_s$			1330	Vrms	Note 8-4
Kick-off voltage(0°C) (Reference Value)	$V_s$			1570	Vrms	

Note 8-2 : In order to satisfy the quality of B/L , no matter use what kind of inverter , the output lamp current must between Min. and Max. to avoid the abnormal display image caused by B/L.

Note 8-3 : The waveform of lamp driving voltage should be as closed to a perfect sine wave as possible.

Note 8-4 : The Kick-off times  $\geq 1$ sec.

**Back Light driving**

Back Light Connector : JST BHSR-02VS-1, Pin No. : 2 , Pitch : 3.5 mm

Pin No	Symbol	Description	Remark
1	VL1	Input terminal (Hi voltage side)	
2	VL2	Input terminal (Low voltage side)	Note 8-5

Note 8-5 : Low voltage side of back light inverter connects with Ground of inverter circuits.

**8-3) Power Consumption**

Ta= 25 °C

Parameter	Symbol	Conditions	TYP.	MAX	Unit	Remark
Supply current for Gate Driver (Hi level)	$I_{GH}$	$V_{GH} = +17V$	0.11	0.17	mA	
Supply current for Gate Driver (Low level)	$I_{EE}$	$V_{EE} = -12V$	0.13	0.20	mA	$V_{EE}$ center voltage
Supply current for Source Driver(Digital)	$I_{DD1}$	$V_{DD1} = +3.3V$	2.4	6.0	mA	
Supply current for Source Driver(Analog)	$I_{DD2}$	$V_{DD2} = +5V$	14	20	mA	
Supply current for Gate Driver (Digital)	$I_{CC}$	$V_{CC} = +3.3V$	0.15	0.225	mA	
LCD Panel Power Consumption			81.85	125.83	mW	Note 8-6
Back Light Lamp Power Consumption			3.92		W	Note 8-7

Note 8-6 : The power consumption for back light is not included.

Note 8-7 : Back light lamp power consumption is calculated by  $I_L \times V_L$ .



**8-4) Timing Characteristics Of Input Signals**

Characteristics	Symbol	Min.	Typ.	Max.	Unit	Remark
Rising time	$t_r$	-	-	10	ns	
Falling time	$t_f$	-	-	10	ns	
High and low level pulse width	$t_{CPH}$	73	78	83	ns	CPH1~CPH3
CPH pulse duty	$t_{CWH}$	40	50	60	%	CPH1~CPH3
STH setup time	$t_{SUH}$	20	-	-	ns	STHR,STHL
STH hold time	$t_{HDH}$	20	-	-	ns	STHR,STHL
STH pulse width	$t_{STH}$	-	1	-	$t_{CPH}$	STHR,STHL
STH period	$t_H$	61.5	63.5	65.5	$\mu s$	STHR,STHL
OEH pulse width	$t_{OEH}$	-	2.08	-	$\mu s$	OEH
Sample and hold disable time	$t_{DIS1}$	-	5.26	-	$\mu s$	
OEV pulse width	$t_{OEV}$	-	16	-	$\mu s$	OEV
CKV pulse width	$t_{CKV}$	-	32	-	$\mu s$	CKV
Clean enable time	$t_{DIS2}$	-	8.02	-	$\mu s$	
Horizontal display timing range	$t_{DH}$	-	640	-	$t_{CPH}/3$	
STV setup time	$t_{SUV}$	400	-	-	ns	STVU,STVD
STV hold time	$t_{HDV}$	400	-	-	ns	STVU,STVD
STV pulse width	$t_{STV}$	-	-	1	$t_H$	STVU,STVD
Horizontal lines per field	$t_v$	256	262	268	$t_H$	
Vertical display start	$t_{SV}$		10	-	$t_H$	
Vertical display timing range	$t_{DV}$		220	-	$t_H$	
VCOM rising time	$t_{rCOM}$		-	5	$\mu s$	
VCOM falling time	$t_{fCOM}$		-	5	$\mu s$	
VCOM delay time	$t_{DCOM}$		-	3	$\mu s$	
RGB delay time	$t_{DRGB}$		-	1	$\mu s$	

8-5) Signal Timing Waveforms

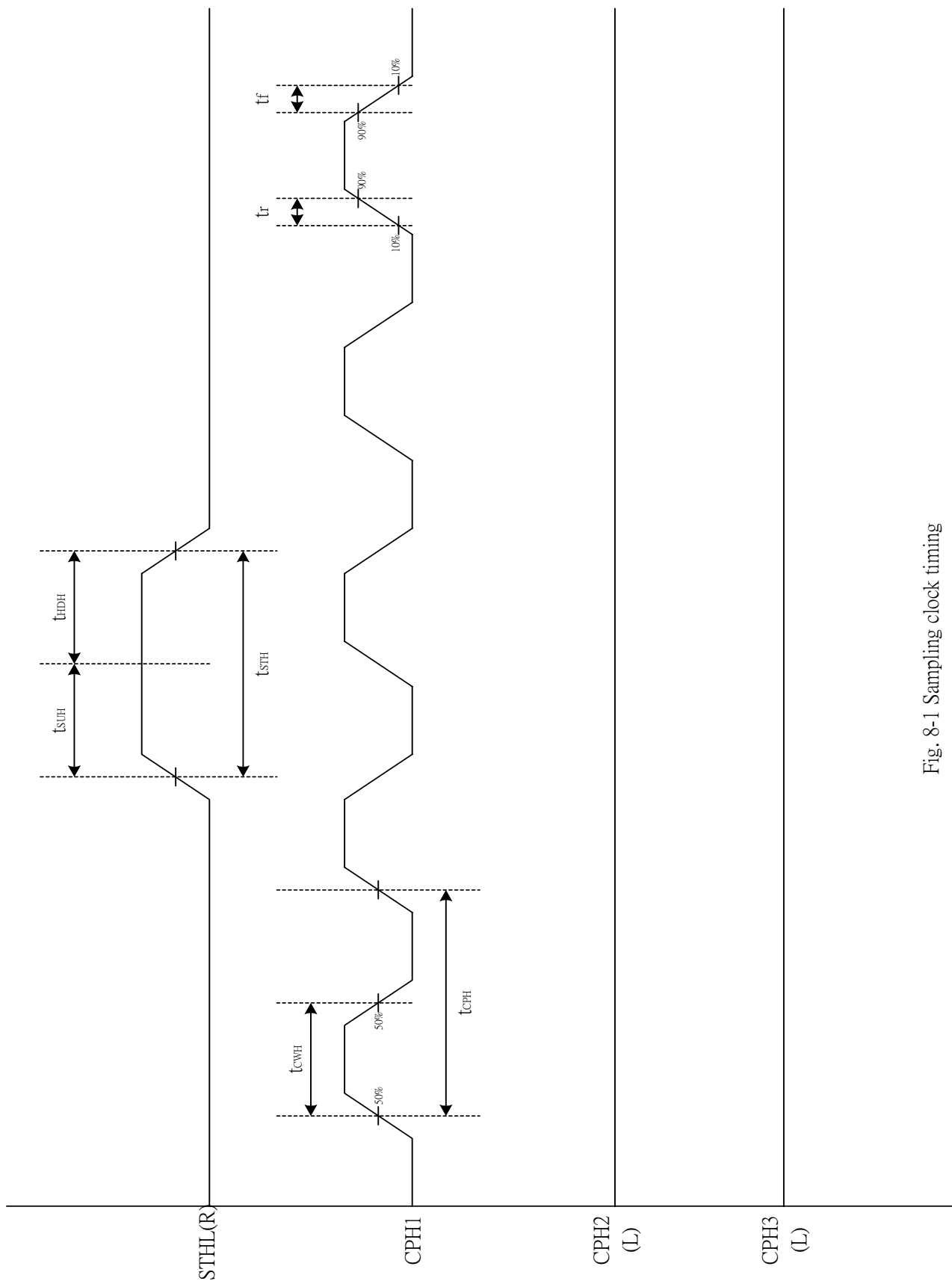

Fig. 8-1 Sampling clock timing

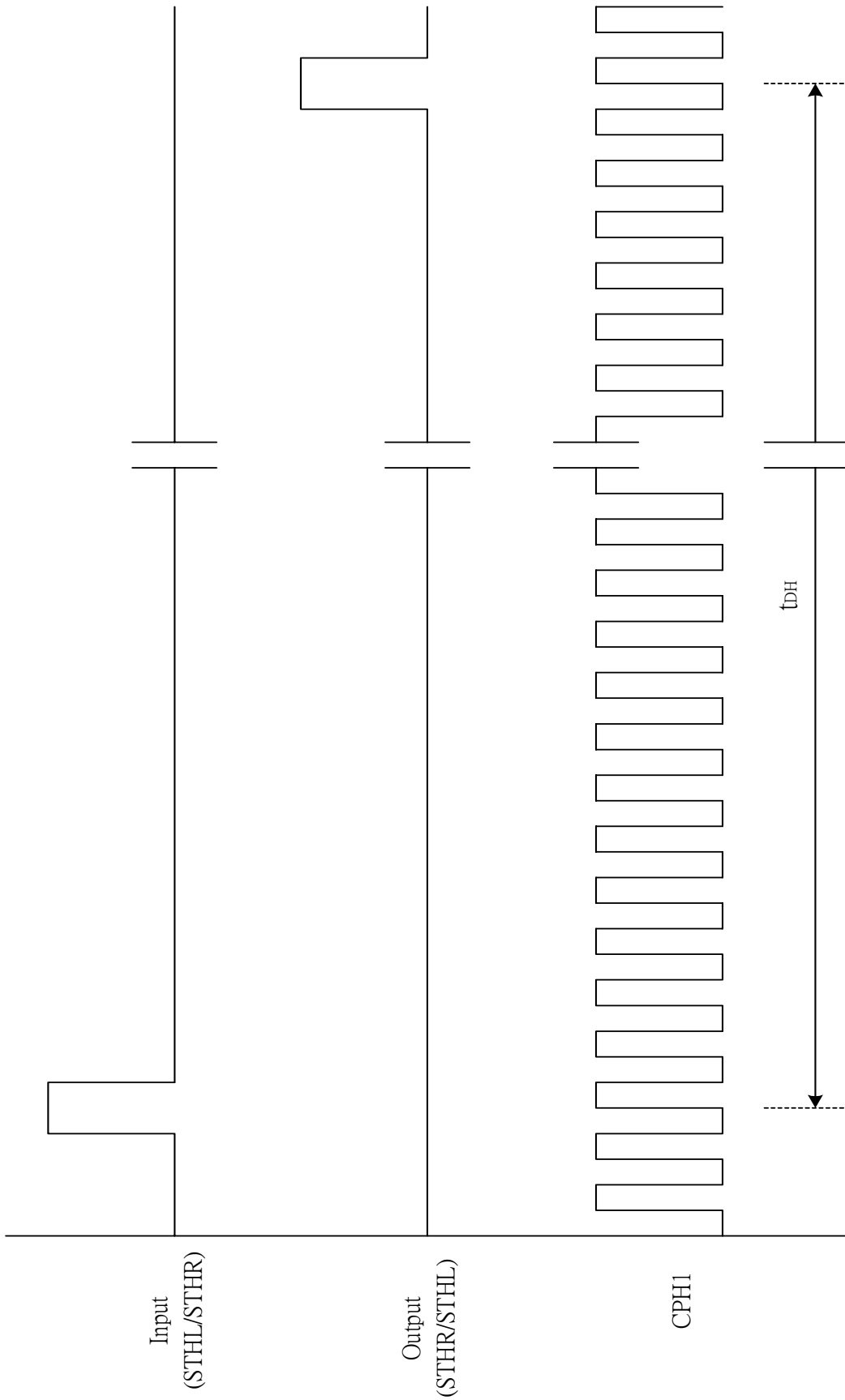

Fig. 8-2 Horizontal display timing range

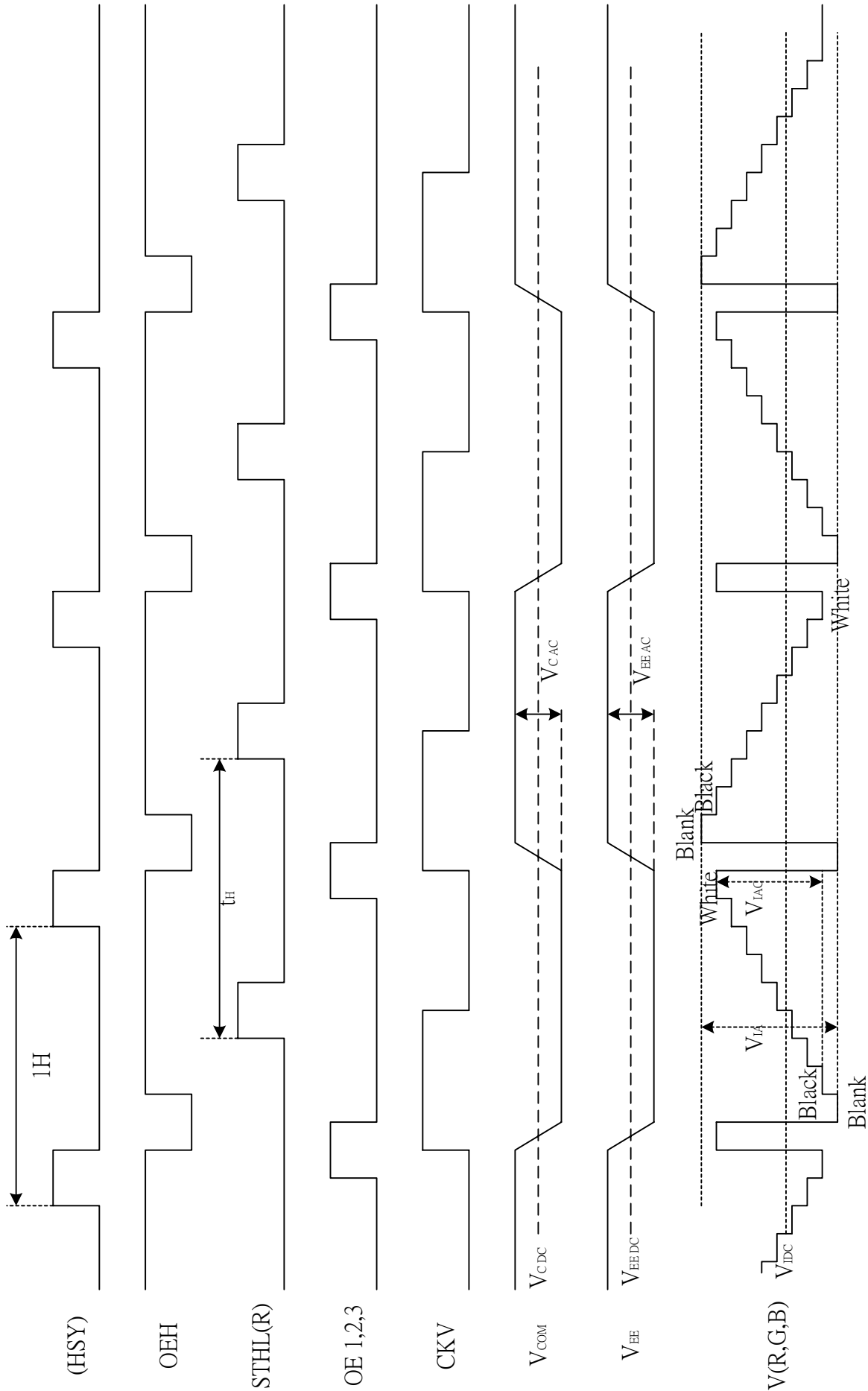
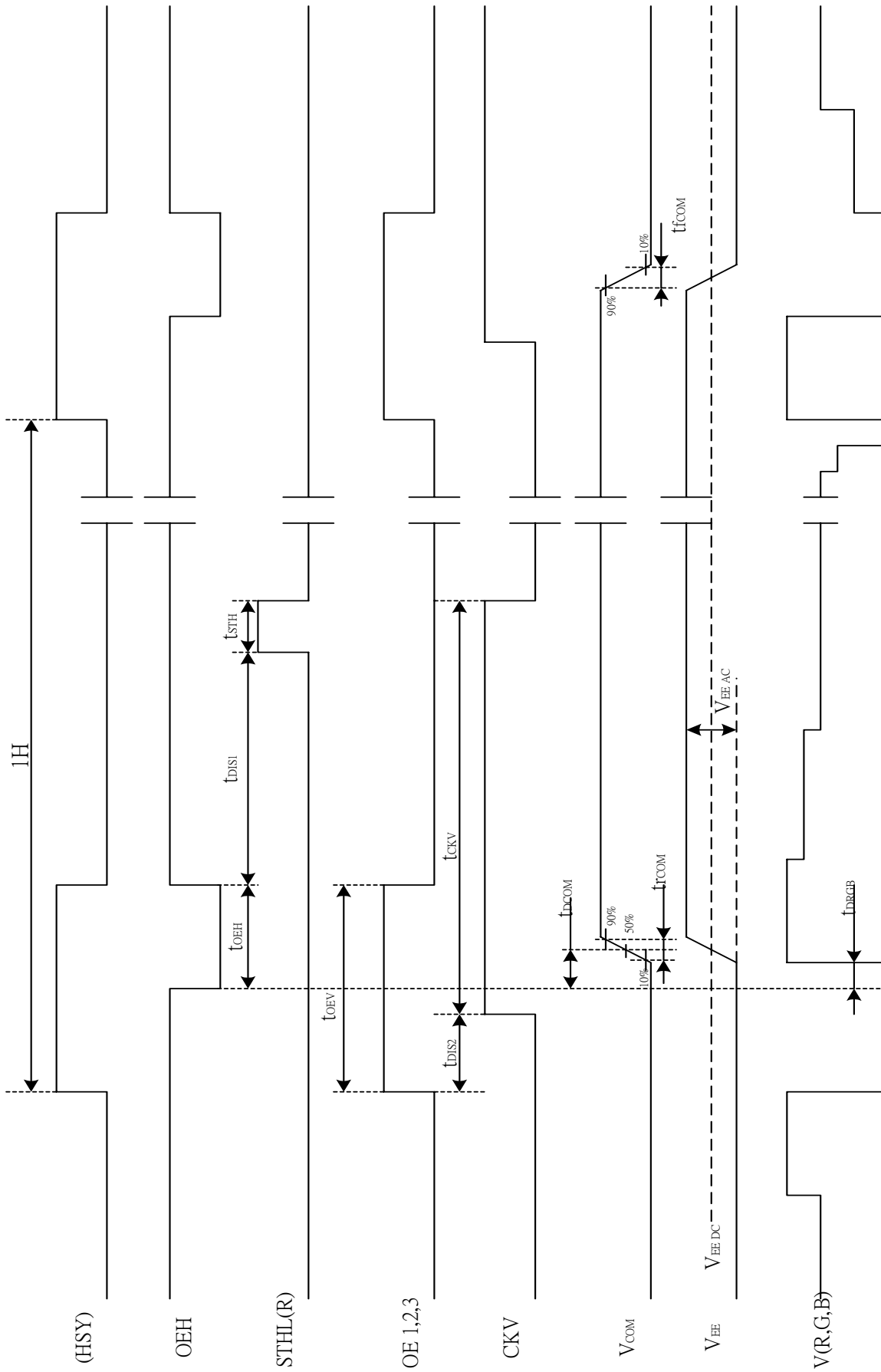

Fig. 8-3 (a) Horizontal timing



Note : The falling edge of OEV should be synchronized with the falling edge of OEH

Fig. 8-3 (b) Detail horizontal timing

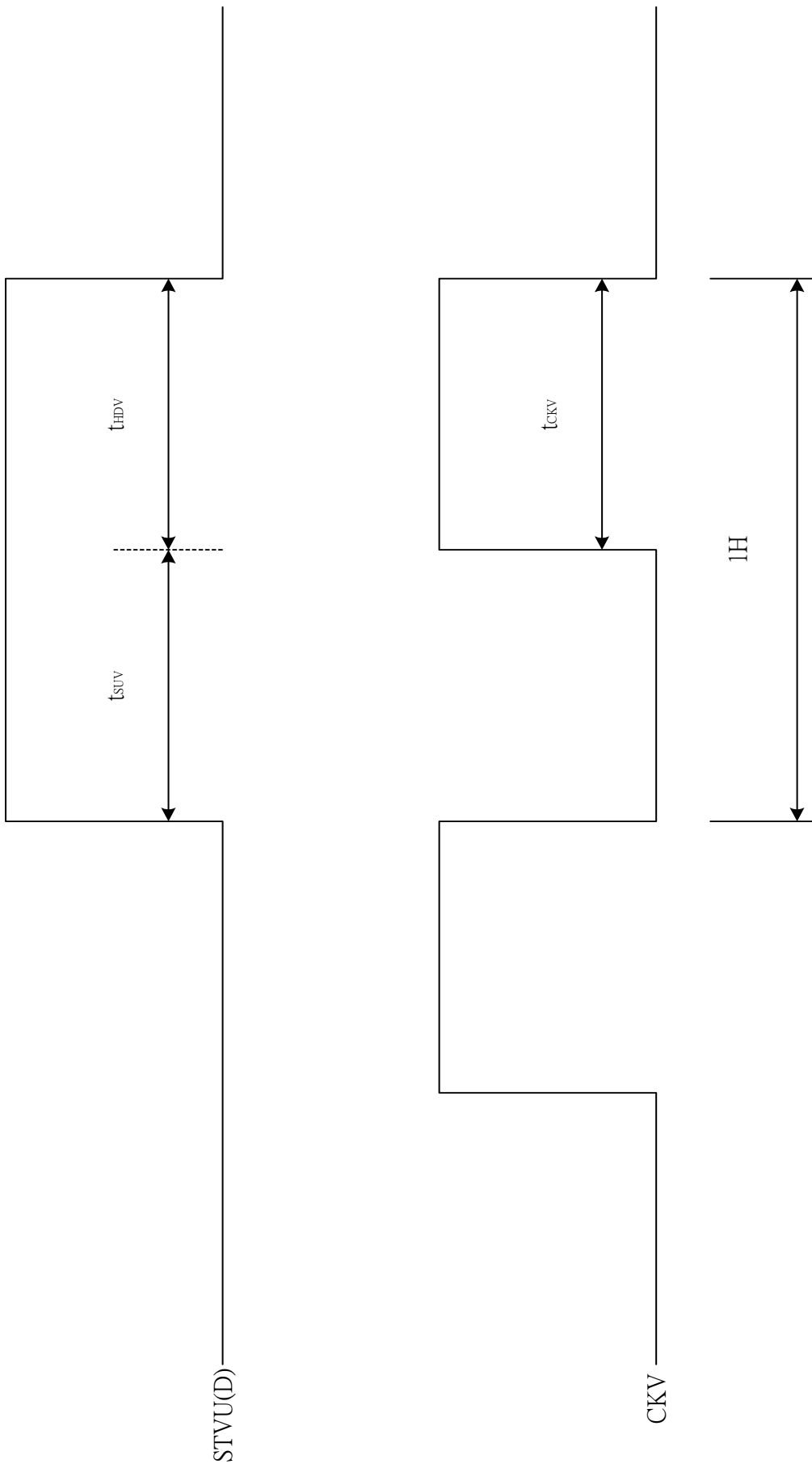

Fig. 8-4 Vertical shift clock timing

Vertical timing (From up to down)

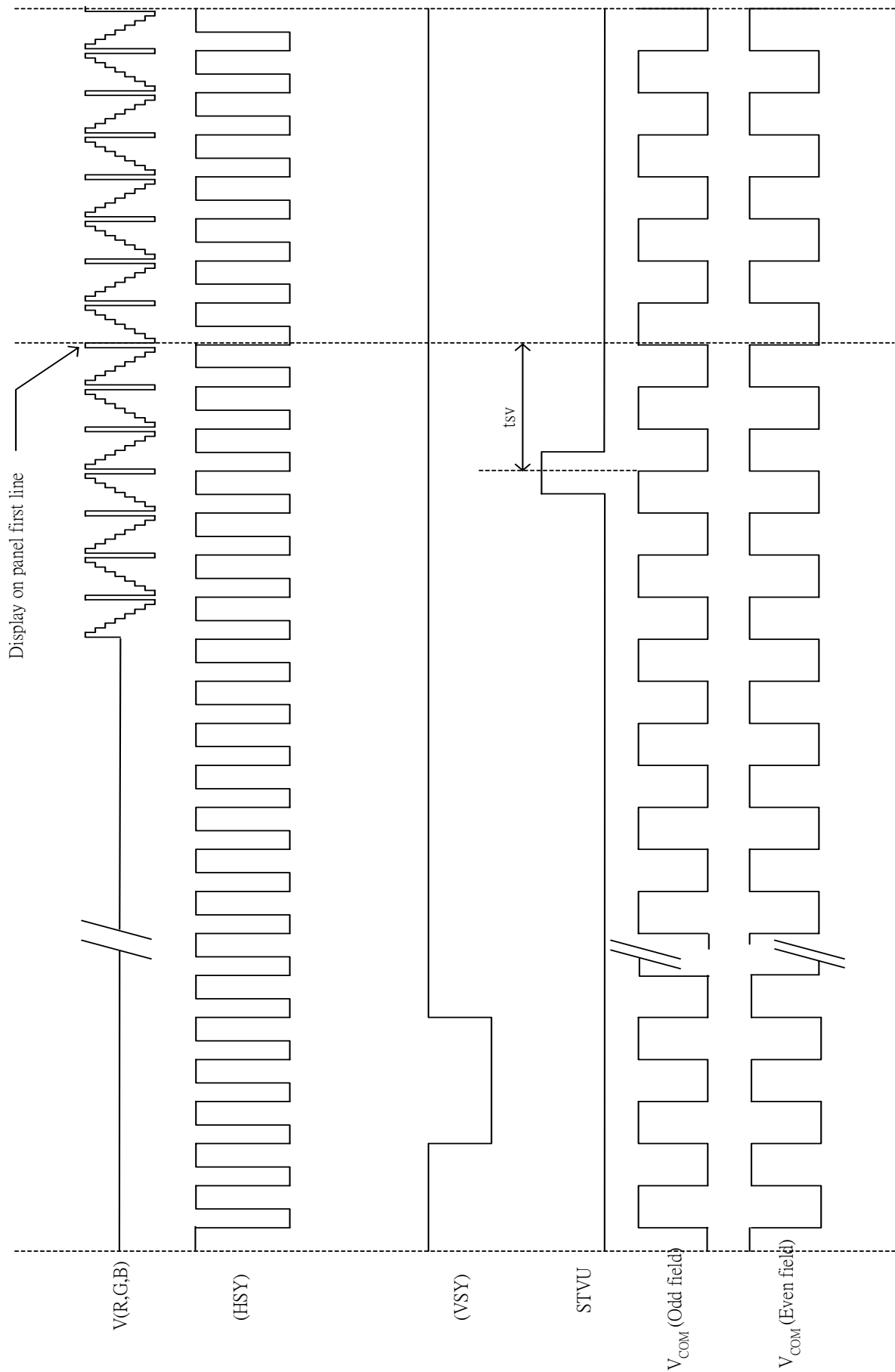

Fig. 8-5 (a) Vertical timing (From Up to Down)

Vertical timing (From down to up)

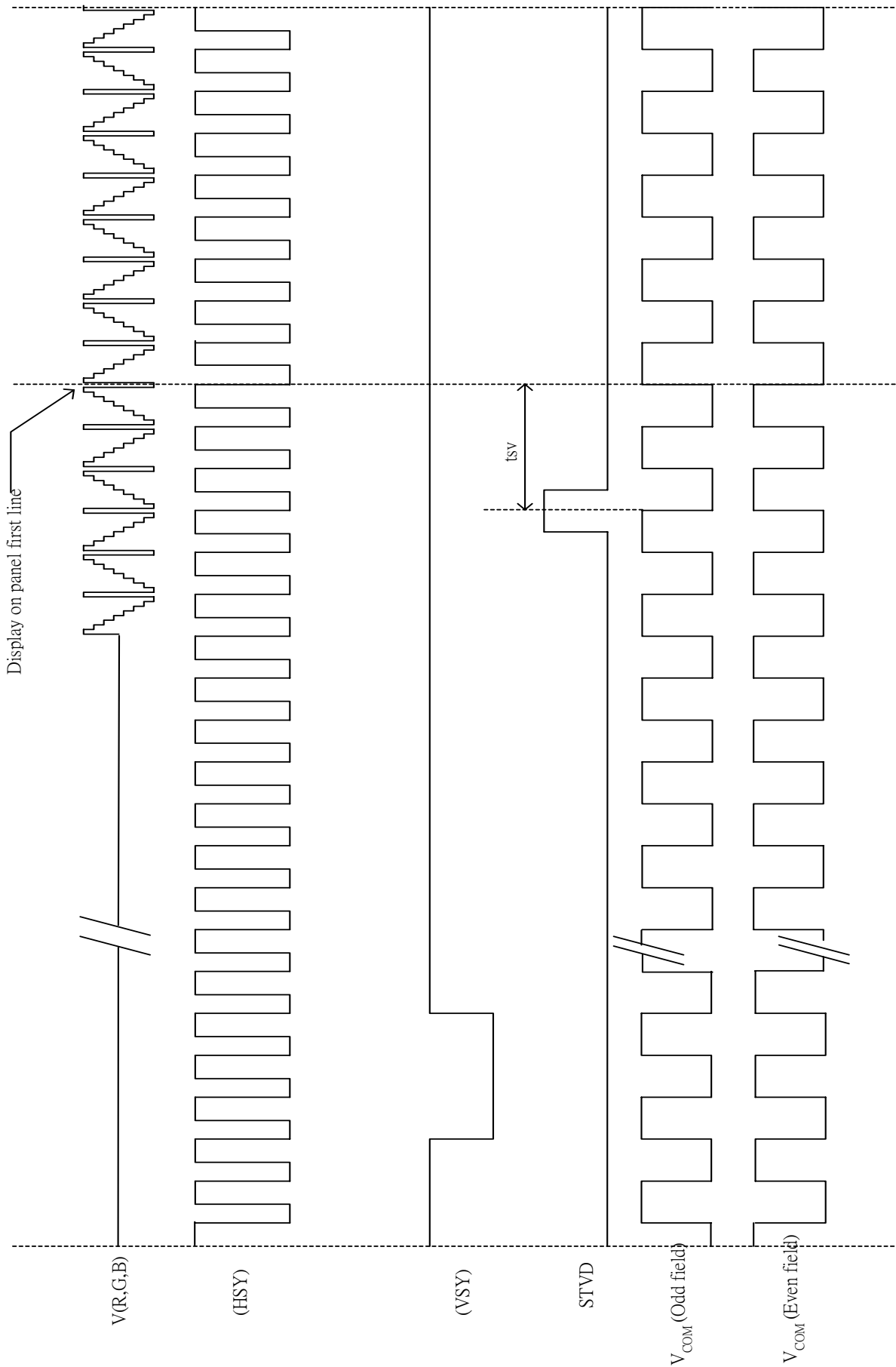
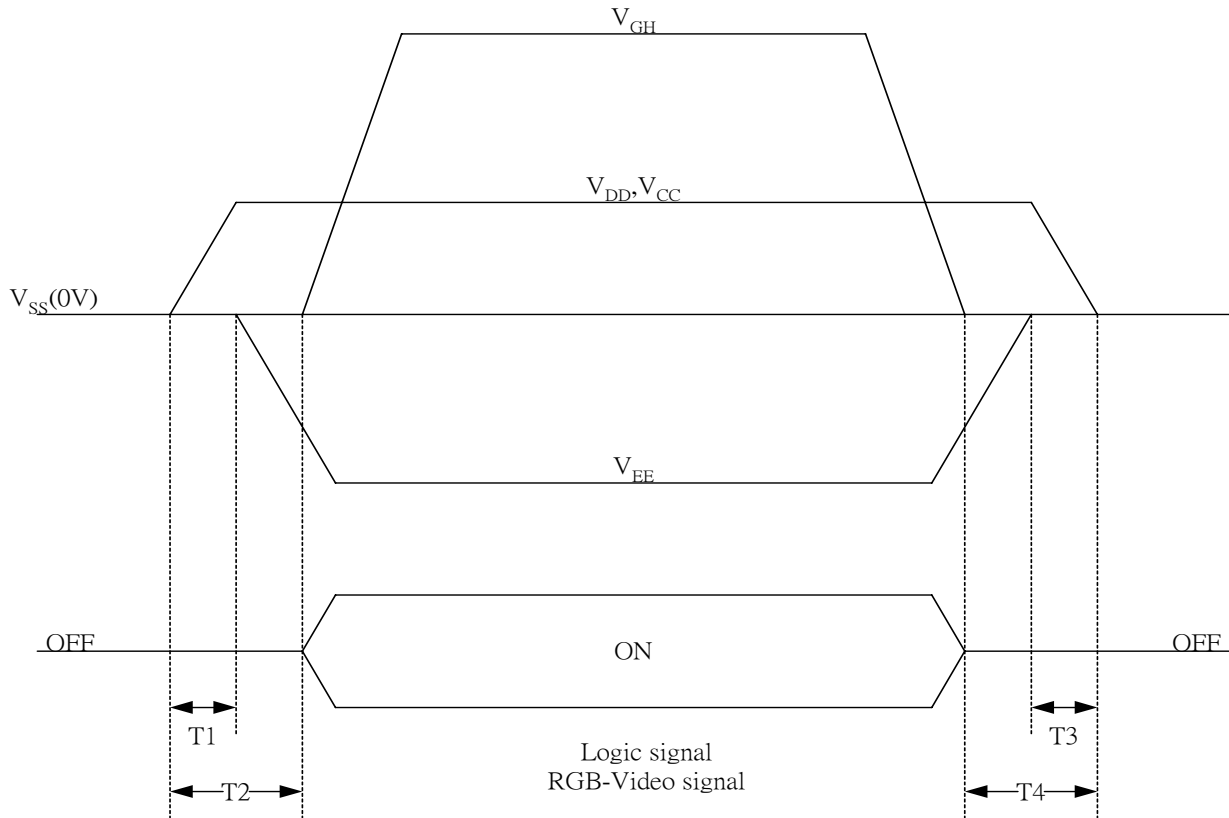

Fig. 8-5 (b) Vertical timing (From Down to Up)



**9. Power on Sequence**

The Power on Sequence only effect by  $V_{CC}$ ,  $V_{SS}$ ,  $V_{DD}$ ,  $V_{EE}$  and  $V_{GH}$ , the others do not care.



- 1)  $10\text{ms} \leq T1 < T2$
- 2)  $0\text{ms} < T3 \leq T4 \leq 10\text{ms}$

**10. Optical Characteristics**
**10-1) Specification**

$T_a = 25^\circ\text{C}$

Parameter		Symbol	Condition	MIN.	TYP.	MAX.	Unit	Remarks
Viewing Angle	Horizontal	$\theta 21, \theta 22$	$CR \geq 10$	55	60		deg	Note 10-1
	Vertical	$\theta 12$		35	40		deg	
		$\theta 11$		50	55		deg	
Contrast Ratio		CR	At optimized Viewing angle	200	350			Note 10-2
Response time	Rise	$T_r$	$\theta = 0^\circ$		15	30	ms	Note 10-4
	Fall	$T_f$			25	50	ms	
Brightness				330	400		$\text{cd}/\text{m}^2$	Note 10-3
Uniformity		U		70	75		%	Note 10-5
White Chromaticity	x		$\theta = 0^\circ$	0.280	0.310	0.340		Note 10-3
	y			0.300	0.330	0.360		
Lamp Life Time $+25^\circ\text{C}$				20000	30000		hr	

Note 10-1 : The definitions of viewing angles

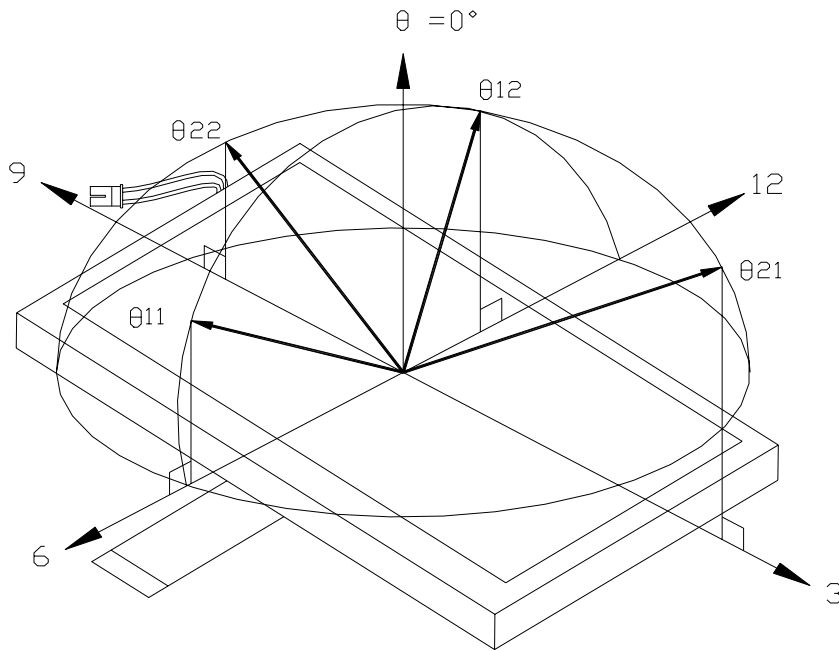

Note 10-2 :  $CR = \frac{\text{Luminance when Testing point is White}}{\text{Luminance when Testing point is Black}}$   
 (Testing configuration see 10-2 )  
 Contrast Ratio is measured in optimum common electrode voltage.

Note 10-3 : 1.Topcon BM-7(fast) luminance meter 2° field of view is used in the testing (after 20~30 minutes operation).  
 2.Lamp current : 6 mA  
 3.Inverter model : TDK-347.

Note 10-4 : The definition of response time:

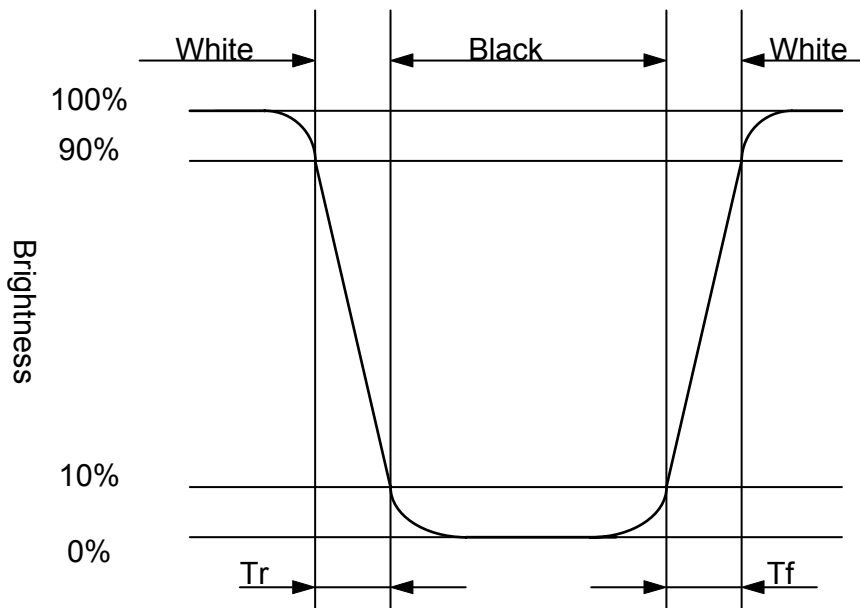

Note 10-5 : The uniformity of LCD is defined as

$$U = \frac{\text{The Minimum Brightness of the 9 testing Points}}{\text{The Maximum Brightness of the 9 testing Points}}$$

Luminance meter : BM-5A or BM-7 fast (TOPCON)

Measurement distance : 500 mm +/- 50 mm

Ambient illumination : < 1 Lux

Measuring direction : Perpendicular to the surface of module

The test pattern is white (Gray Level 63).

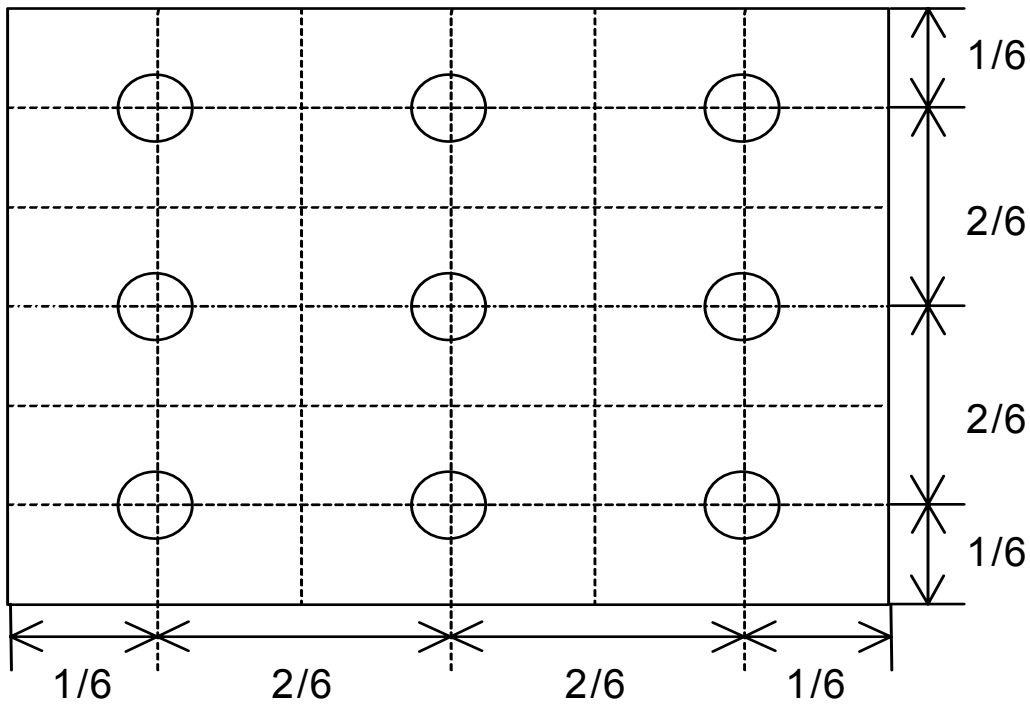

10-2) Testing configuration

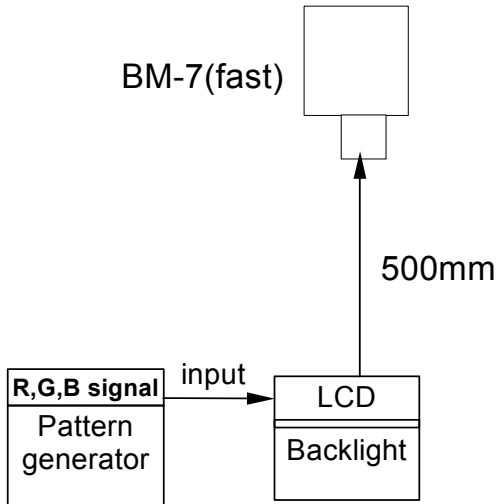

Caution: 1. Environmental illumination  $\leq 1$  lux  
 2. Before test CR, Vcom voltage must be adjusted carefully to get the best CR.

- LCD Display Testing Point Testing Point

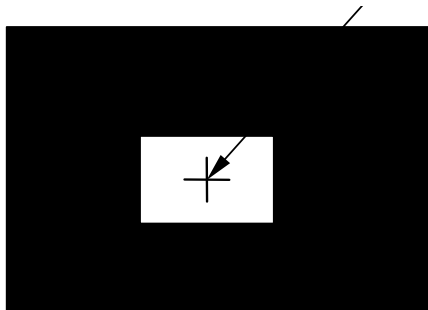

Pattern A

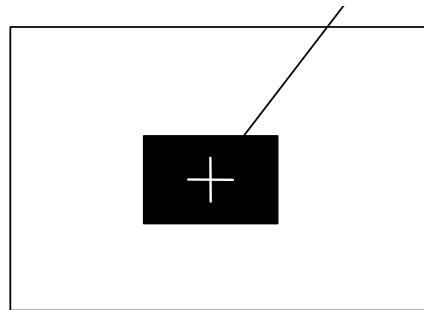

Pattern B

- R, G, B Waveform of Pattern A at Testing Point

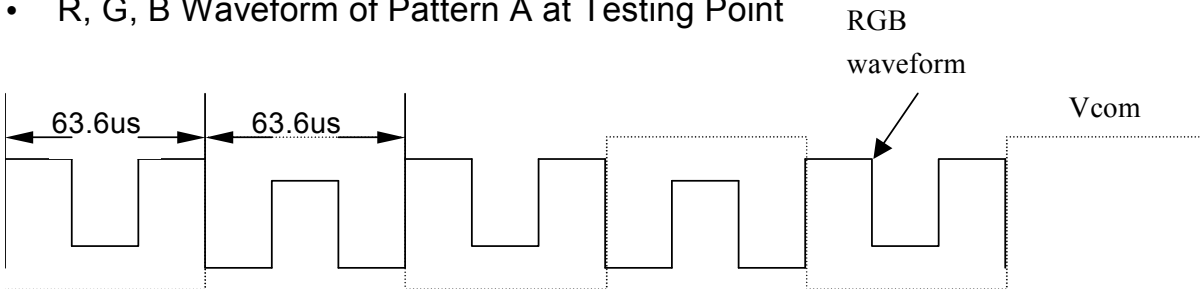

- R, G, B Waveform of Pattern B at Testing Point

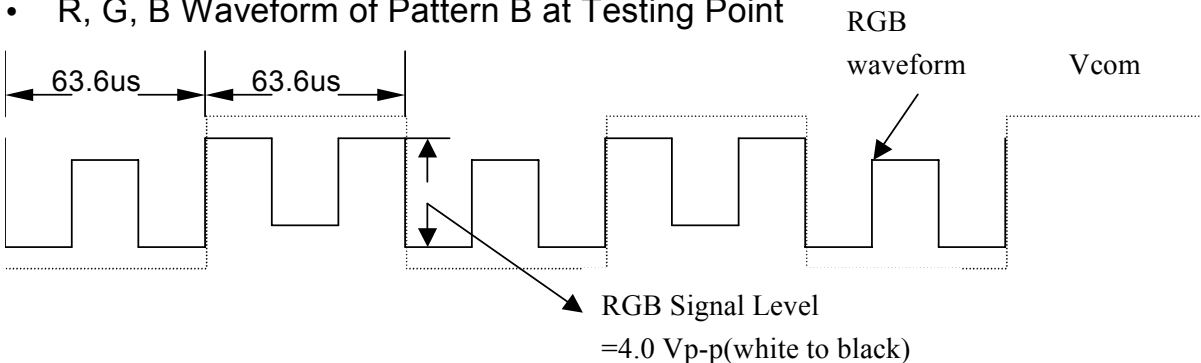

---

## 11. Handling Cautions

### 11-1) Mounting of module

- a) Please power off the module when you connect the input/output connector.
- b) Please connect the ground pattern of the inverter circuit surely. If the connection is not perfect, some following problems may happen possibly.
  1. The noise from the backlight unit will increase.
  2. The output from inverter circuit will be unstable.
  3. In some cases a part of module will heat.
- c) Polarizer which is made of soft material and susceptible to flaw must be handled carefully.
- d) Protective film (Laminator) is applied on surface to protect it against scratches and dirt. It is recommended to peel off the laminator before use and taking care of static electricity.

### 11-2) Precautions in mounting

- a) When metal part of the TFT-LCD module (shielding lid and rear case) is soiled, wipe it with soft dry cloth.
- b) Wipe off water drops or finger grease immediately. Long contact with water may cause discoloration or spots.
- c) TFT-LCD module uses glass which breaks or cracks easily if dropped or bumped on hard surface. Please handle with care.
- d) Since CMOS LSI is used in the module. So take care of static electricity and earth yourself when handling.

### 11-3) Others

- a) Do not expose the module to direct sunlight or intensive ultraviolet rays for many hours.
- b) Store the module at a room temperature place.
- c) The voltage of beginning electric discharge may over the normal voltage because of leakage current from approach conductor by to draw lump read lead line around.
- d) If LCD panel breaks, it is possibly that the liquid crystal escapes from the panel. Avoid putting it into eyes or mouth. When liquid crystal sticks on hands, clothes or feet. Wash it out immediately with soap.
- e) Observe all other precautionary requirements in handling general electronic components.

### 11-4) Polarizer mark

The polarizer mark is to describe the direction of wide view angle film how to mach up with the rubbing direction.

**12. Reliability Test**

No.	Test Item	Test Condition
1	High Temperature Storage Test	Ta = +80°C, 240 hrs
2	Low Temperature Storage Test	Ta = -30°C, 240 hrs
3	High Temperature Operation Test	Ta = +80°C, 240 hrs
4	Low Temperature Operation Test	Ta = -20°C, 240 hrs
5	High Temperature & High Humidity Operation Test	Ta = +60°C, 90%RH, 240 hrs
6	Thermal Cycling Test (non-operating)	-20°C → +70°C, 200 Cycles 30 min 30 min
7	Vibration Test (non-operating)	Frequency : 10 ~ 55 Hz Amplitude : 1 mm Sweep time : 11 mins Test Period : 6 Cycles for each direction of X, Y, Z
8	Shock Test (non-operating)	100G, 6ms Direction : ±X, ±Y, ±Z Cycle : 3 times
9	Electrostatic Discharge Test (non-operating)	200pF, 0Ω ±200V 1 time / each terminal

Ta: ambient temperature

[Criteria]

Under the display quality test conditions with normal operation state, there should be no change which may affect practical display function.

**13. Indication of Lot Number Label**

a) Indicated contents of the label

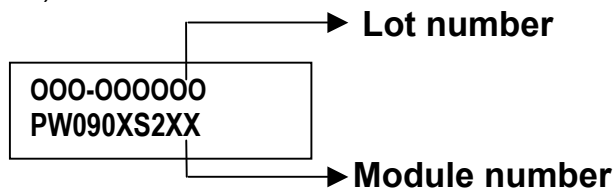

Contents of lot number : 1<sup>st</sup>~3<sup>rd</sup>—The OEM product

5<sup>th</sup>—Production year : 1999⇒9, 2000⇒A, 2001⇒B.....

6<sup>th</sup>—Production month : 1, 2, 3,....9, A, B, C

7<sup>th</sup>~8<sup>th</sup>—Production size : 9.0"⇒90

9<sup>th</sup>~10<sup>th</sup>—Serial numbers : 01~99

14. Block Diagram

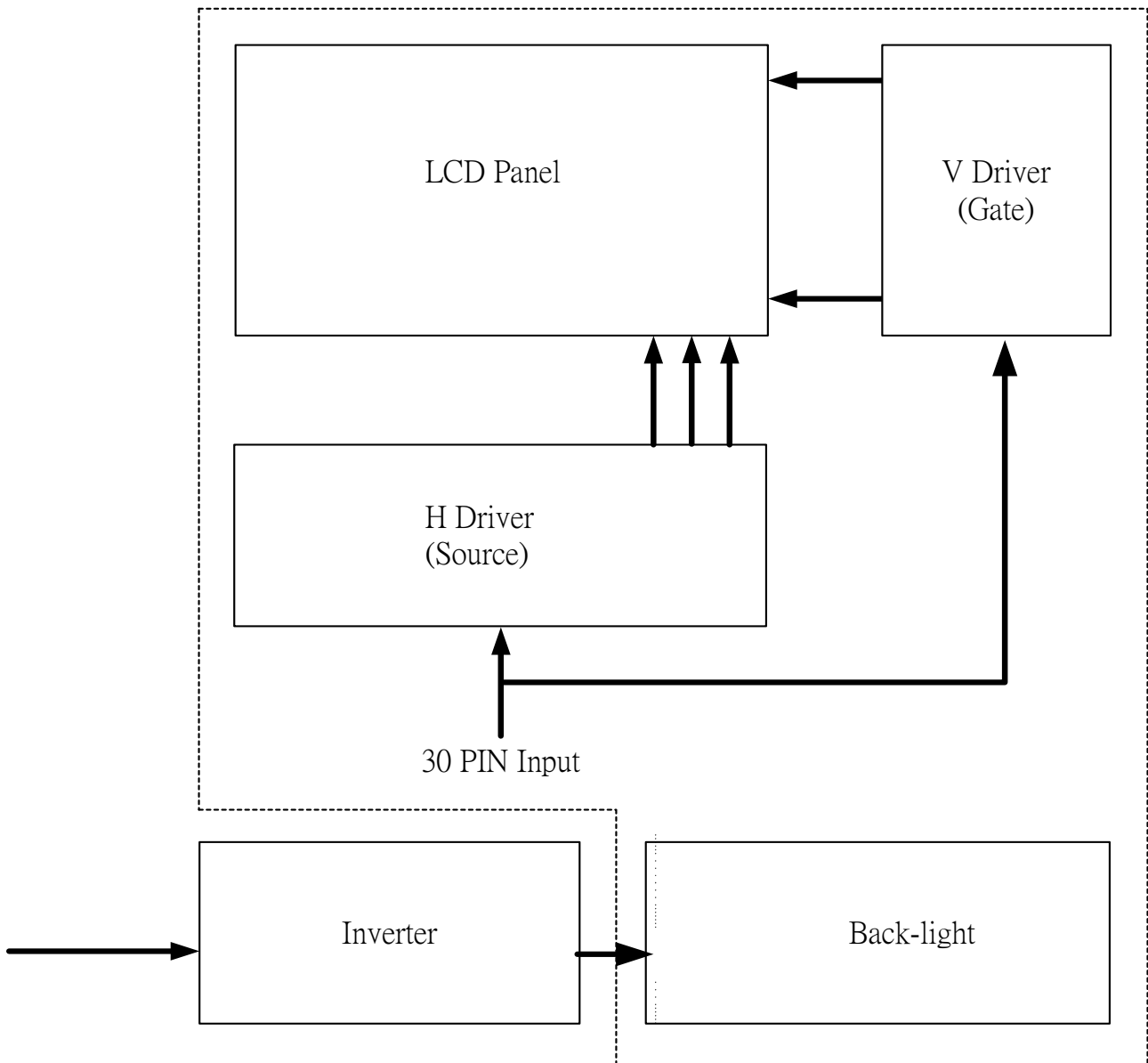

15. Packing

ZONE	REV.	DOCUMENT NO.	DESCRIPTION	DATE	REV.BY																									
<p><b>NOTE:</b></p> <p>1.Q'TY: 20 pcs panel/carton.                  2.Dimension: 530*295*230mm                  3.Weight: 8.0 Kg</p>																														
		<table border="1" style="width:100%; border-collapse: collapse;"> <thead> <tr> <th>ITEM</th> <th>PART NO.</th> <th>DESCRIPTION</th> <th>QTY</th> <th>REMARK</th> </tr> </thead> <tbody> <tr> <td>4</td> <td>50-010011</td> <td>CARTON</td> <td>1</td> <td></td> </tr> <tr> <td>3</td> <td>50-0500131</td> <td>防靜電氣泡袋 Pink</td> <td>20</td> <td>抗靜電</td> </tr> <tr> <td>2</td> <td></td> <td>9"SW Module</td> <td>20</td> <td></td> </tr> <tr> <td>1</td> <td>50-0300931</td> <td>瓦楞隔板緩衝材</td> <td>1</td> <td>上蓋+底座</td> </tr> </tbody> </table>		ITEM	PART NO.	DESCRIPTION	QTY	REMARK	4	50-010011	CARTON	1		3	50-0500131	防靜電氣泡袋 Pink	20	抗靜電	2		9"SW Module	20		1	50-0300931	瓦楞隔板緩衝材	1	上蓋+底座		
ITEM	PART NO.	DESCRIPTION	QTY	REMARK																										
4	50-010011	CARTON	1																											
3	50-0500131	防靜電氣泡袋 Pink	20	抗靜電																										
2		9"SW Module	20																											
1	50-0300931	瓦楞隔板緩衝材	1	上蓋+底座																										
MTL.SPEC.		UNSPECIFIED TOL'S		REMARK																										
		ANGLE																												
		ROUGHNESS																												
APPROVE		SCALE	UNIT	SHEET	DWG.TITLE																									
CHECK				1 OF 1	9"SW Module Packing Draw																									
DRAWN	Jimmy	MTL.NO.		DWG FILE:	REV. 01																									
	'04.07.12				A4 SIZE																									



**Revision History**

Rev.	Issued Date	Revised Contents
1.0	Jul. 28 , 2004	NEW
1.1	Oct. 08 , 2004	Modify Page 22 : Reliability test condition High Temperature Storage Test (From +70°C to +80°C) Low Temperature Storage Test (From -10°C to -30°C) High Temperature Operation Test (From +60°C to +80°C) Low Temperature Operation Test (From 0°C to -20°C) High Temperature & High Humidity Operation Test (From +50°C, 80%RH to +60°C, 90%RH) Thermal Cycling Test (From -25°C → +70°C to -20°C → +70°C)