

R2862A Digital 2R Receiver OC-192/STM-64



Features

- Integrated limiting amplifier, 550 mVp-p output typical
- High sensitivity, -20 dBm typical
- Wide dynamic range, 2 dBm overload typical
- Hermetically sealed
- ac-coupled output
- Threshold adjust for eye crossing

Applications

- 10 Gbits/s short, intermediate, and long-haul systems
- SONET/SDH equipment
- Datacom equipment

Description

The R2862A 10 Gbits/s receiver is a PIN receiver with integrated transimpedance amplifier (TIA) and limiting amplifier (LA). An integrated voltage regulator provides accurate control of the TIA, thus allowing the TIA to be powered externally by a wide range of voltages. In addition, a threshold adjust provides the capability to change the eye crossing point. The threshold pin may be left open, in which case the LA self-regulates to its nominal half-way setting.

Agere Systems Inc. offers several 1R and 2R high-speed receiver components for 10 Gbits/s and 12.5 Gbits/s applications. APD and PIN versions are available in a 6-pin hermetic package with coaxial output. In addition, Agere Systems also offers a PIN receiver with coplanar waveguide in a multisource agreement form-factor or a smaller, space-sensitive package. For more information about the complete line of high-speed receiver products, please visit the Agere Systems' website at www.agere.com/opto.

Absolute Maximum Ratings

Stresses in excess of the absolute maximum ratings can cause permanent damage to the device. These are absolute stress ratings only. Functional operation of the device is not implied at these or any other conditions in excess of those given in the operational sections of the data sheet. Exposure to absolute maximum ratings for extended periods can adversely affect device reliability.

Parameter	Symbol	Min	Max	Unit
Storage Case Temperature Range	T _{stg}	-40	85	°C
TIA Supply Voltage	V _{CC}	GND	6	V
TIA and LA Supply Voltage	V _{EE}	-6	GND	V
Photodiode Bias Voltage	V _{PD}	GND	14	V
Threshold Adjust Voltage	V _T	-2	2	V
Optical Input Power	P _{IN}	—	4	dBm
ESD-susceptibility, dc pins*	—	—	500 (target)	V
ESD-susceptibility, RF pins*	—	—	75	V

* Based on human-body model of R = 1500 Ω and C = 100 pF. In general, precautions should be taken to avoid damage to the device.

Recommended Operating Conditions

Table 1. Recommended Operating Conditions

Parameter	Symbol	Min	Typ	Max	Unit
Bit Rate	BR	—	9.953	10.7	Gbits/s
Operating Case Temperature Range	T _{OP}	-5	25	70	°C
TIA Supply Voltage	V _{CC}	3.1	5	5.25	V
TIA and LA Supply Voltage	V _{EE}	-5.5	-5.2	-4.75	V
Photodiode Bias Voltage	V _{PD}	3.1	5	5.25	V
Threshold Adjust Voltage	V _T	-1.5	Open	1.5	V
Optical Wavelength	λ	1280	—	1580	nm
Optical Input Power	P _{IN}	-19	—	0	dBm

Electrical/Optical Characteristics

Table 2. Electrical/Optical Characteristics (Specified characteristics apply for the operating conditions in Table 1 at BOL, unless noted otherwise.)

Parameter	Symbol	Condition	Min	Typ	Max	Unit
Sensitivity*	—	10^{-12} BER, PRBS $2^{31} - 1$	—	-20	-18.5	dBm
Overload*	—	10^{-12} BER, PRBS $2^{31} - 1$	0	2	—	dBm
Responsivity	R	-5 °C to +70 °C case 25 °C case	0.65 0.7	0.75 0.8	—	A/W A/W
Dark Current	I _D	25 °C case	—	—	1.0	nA
Output Voltage	V _{OUT}	Ext. Ratio = 10 dB, PRBS $2^{31} - 1$, P _{in} = -19 dBm to 0 dBm	300	550	750	mVp-p
Transimpedance, Small Signal	Z _T	P _{IN} = -25 dBm	—	100	—	kΩ
Eye Crossing*	—	-19 dBm, V _T open	35	50	65	%
Eye Crossing: V _T = -1 V V _T = 1 V	—	P _{IN} = -19 dBm P _{IN} = -19 dBm	60 —	— —	— 40	% %
Rise/Fall Time* (20%—80%)	t _R /t _F	P _{IN} = -19 dBm	—	20	35	ps
Bandwidth, Small Signal	f _{3 dB}	P _{IN} = -25 dBm, -3 dB Relative to 300 MHz	7	9	—	GHz
Low-frequency Cutoff	—	P _{IN} = -25 dBm, Relative to 300 MHz	—	—	30	kHz
Supply Current, V _{CC}	I _{CC}	—	—	80	120	mA
Supply Current, V _{EE}	I _{EE}	—	—	225	300	mA
Logic Sense	—	—	—	Non-inverting	—	—
Optical Return Loss	RL	Not Including Connector	27	—	—	dB

* Test transmitter: external modulator, BW > 10 GHz, $\lambda = 1550 \pm 30$ nm; extinction ratio > 10 dB (e.g., Agilent™ Model 83433).

Pin Information

Table 3. Pin Descriptions

Pin No.	Symbol	Function
1	NC	No Connect
2	VCC	TIA, via regulator
3	VPD	Photodiode
4	VEE	TIA and LA
5	VT	Threshold adjust for LA; may be left open
6	GND	Ground

Block Diagram

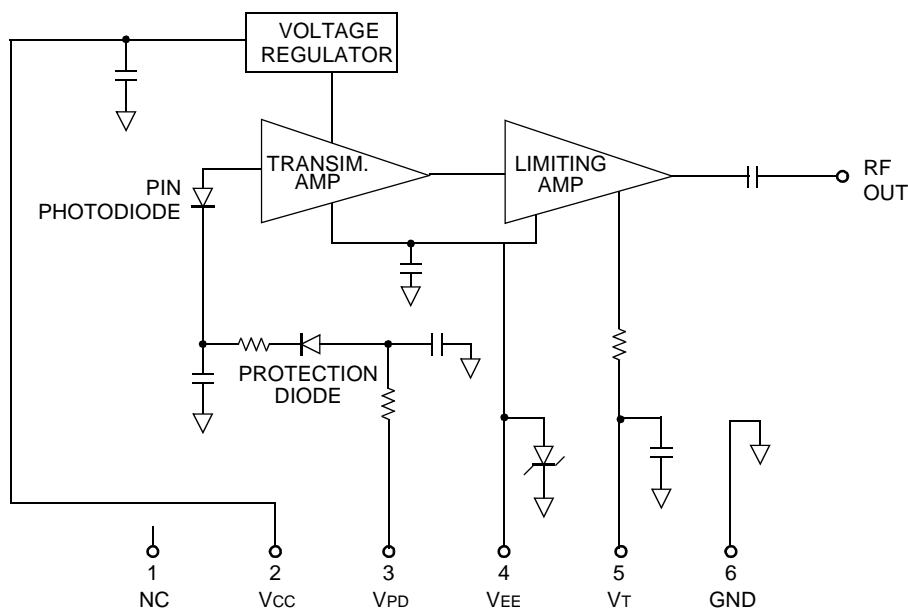

1-xxxx

Ordering Information

For ordering information, please contact an account manager at Opto West, Agere Systems Inc., 1-800-362-3891 (for sales staff, please press option 2).

Agilent is a trademark of Agilent Technologies, Inc.
K-Connector is a trademark of Anritsu Company.

For additional information, contact your Agere Systems Account Manager or the following:

INTERNET: <http://www.agere.com>

E-MAIL: docmaster@agere.com

N. AMERICA: Agere Systems Inc., 555 Union Boulevard, Room 30L-15P-BA, Allentown, PA 18109-3286

1-800-372-2447, FAX 610-712-4106 (In CANADA: **1-800-553-2448**, FAX 610-712-4106)

ASIA: Agere Systems Hong Kong Ltd., Suites 3201 & 3210-12, 32/F, Tower 2, The Gateway, Harbour City, Kowloon

Tel. (852) 3129-2000, FAX (852) 3129-2020

CHINA: **(86) 21-5047-1212** (Shanghai), **(86) 10-6522-5566** (Beijing), **(86) 755-695-7224** (Shenzhen)

JAPAN: **(81) 3-5421-1600** (Tokyo), KOREA: **(82) 2-767-1850** (Seoul), SINGAPORE: **(65) 778-8833**, TAIWAN: **(886) 2-2725-5858** (Taipei)

EUROPE: **Tel. (44) 7000 624624**, FAX (44) 1344 488 045

Agere Systems Inc. reserves the right to make changes to the product(s) or information contained herein without notice. No liability is assumed as a result of their use or application.