



Features

- Low Noise and High Intercept Point
- Adjustable Bias Current
- Single 2.5V to 6.0V Power Supply
- 700MHz to 3800MHz Operation
- QFN20, 5mmx5mm Package

Applications

- WiMAX LNA or Linear Driver
- CDMA, PCS, ECS, UMTS LNA
- WLAN LNA
- High Gain Linear Amplification

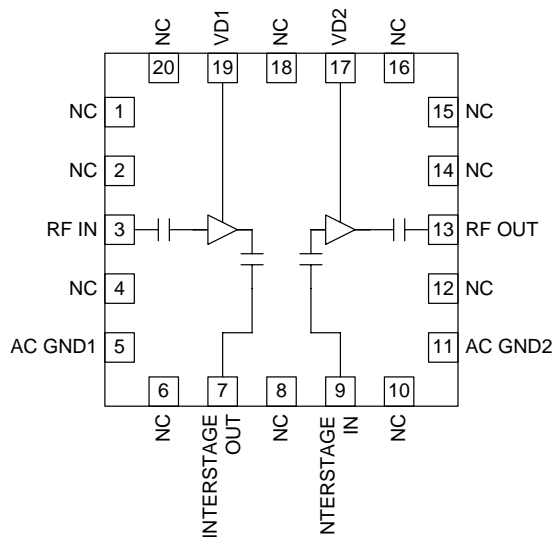

Functional Block Diagram

Product Description

The RF3865 is a low noise amplifier with a high output IP3. The amplifier is self-biased from a single voltage supply with 50Ω input and output ports. The useful frequency range is from 700MHz to 3800MHz. A 1dB noise figure and 36dBm OIP3 performance is achieved with a 5V V_{DD}, 180mA. Current can be increased to raise OIP3 while having minimal effect on noise figure. The IC is featured in a standard QFN, 20-pin, 5mmx5mm package.

Ordering Information

RF3865	Wide Bandwidth, High Linearity Low Noise Amplifier/Linear Driver
RF3865PCK-410	Fully Assembled Evaluation Board with 5 Sample Parts 1.8GHz to 3.8GHz
RF3865PCK-411	700MHz to 1100MHz

Optimum Technology Matching® Applied

- | | | | |
|--------------------------------------|--------------------------------------|--|-----------------------------------|
| <input type="checkbox"/> GaAs HBT | <input type="checkbox"/> SiGe BiCMOS | <input checked="" type="checkbox"/> GaAs pHEMT | <input type="checkbox"/> GaN HEMT |
| <input type="checkbox"/> GaAs MESFET | <input type="checkbox"/> Si BiCMOS | <input type="checkbox"/> Si CMOS | |
| <input type="checkbox"/> InGaP HBT | <input type="checkbox"/> SiGe HBT | <input type="checkbox"/> Si BJT | |

RF MICRO DEVICES®, RFMD®, Optimum Technology Matching®, Enabling Wireless Connectivity™, PowerStar®, POLARIS™ TOTAL RADIO™ and UltimateBlue™ are trademarks of RFMD, LLC. BLUETOOTH is a trademark owned by Bluetooth SIG, Inc., U.S.A. and licensed for use by RFMD. All other trade names, trademarks and registered trademarks are the property of their respective owners. ©2006, RF Micro Devices, Inc.

Absolute Maximum Ratings

Parameter	Rating	Unit
Supply Voltage	0 to +7	V _{DC}
Input RF Level (See Note 1)	+10	dBm
Current Drain, I _{DD}	150 per stage	mA
Operating Ambient Temperature	-40 to +85	°C
Storage Temperature	-40 to +150	°C

Note 1. Max continuous RF IN is +10dBm. The max transient RF IN is +20dBm.



Caution! ESD sensitive device.

The information in this publication is believed to be accurate and reliable. However, no responsibility is assumed by RF Micro Devices, Inc. ("RFMD") for its use, nor for any infringement of patents, or other rights of third parties, resulting from its use. No license is granted by implication or otherwise under any patent or patent rights of RFMD. RFMD reserves the right to change component circuitry, recommended application circuitry and specifications at any time without prior notice.

RoHS status based on EUDirective2002/95/EC (at time of this document revision).

Parameter	Specification			Unit	Condition
	Min.	Typ.	Max.		
High Band					
Frequency	3300		3800	MHz	
Current		180	220	mA	V _{DD} = 5V
Gain		20		dB	+25 °C, V _{DD} = 5V, I _{DD} = 180mA, 3500MHz unless specified
Noise Figure		1.1		dB	
Output IP3		37		dBm	f ₁ = 3500MHz, f ₂ = 3501MHz
Output P1dB		22		dBm	
S11		-17		dB	
S22		-17		dB	
S12		-33		dB	
Mid Band					
Frequency	1800		2700	MHz	
Current		180	220	mA	V _{DD} = 5V
Gain	27.5	28.5	31.0	dB	+25 °C, V _{DD} = 5V, I _{DD} = 180mA, 2000MHz unless specified
Noise Figure	1.0	1.2		dB	
Output IP3	34	36		dBm	f ₁ = 2000MHz, f ₂ = 2001MHz
Output P1dB	21.0	22.5	25.0	dBm	
S11		-10		dB	
S22		-20		dB	
S12		-40		dB	
Low Band					
Frequency	700		1100	MHz	
Current		180	220	mA	V _{DD} = 5V
Gain		33		dB	+25 °C, V _{DD} = 5V, I _{DD} = 180mA, 850MHz unless specified
Noise Figure		1.2		dB	
OIP3		36		dBm	f ₁ = 851MHz, f ₂ = 851MHz
OP1dB		22		dBm	
S11		-15		dB	
S22		-18		dB	
S12		-40		dB	

Pin	Function	Description
1	NC	Not connected.
2	NC	Not connected.
3	RF IN	RF input pin. 50Ω matched. This pin is DC-blocked.
4	NC	Not connected.
5	AC GND1	AC ground. Shunt cap may be added for tuning.
6	NC	Not connected.
7	INTERSTAGE OUT	Interstage RF output.
8	NC	Not connected.
9	INTERSTAGE IN	Interstage RF input.
10	NC	Not connected.
11	AC GND2	AC ground. Shunt resistor may be added to increase I _{DD} and OIP3.
12	NC	Not connected.
13	RF OUT	RF output pin. 50Ω matched. This pin is DC-blocked
14	NC	Not connected.
15	NC	Not connected.
16	NC	Not connected.
17	VD2	Bias voltage. 2.5V to 6.0V applied through bias inductor.
18	NC	Not connected.
19	VD1	Bias voltage. 2.5V to 6.0V applied through bias inductor.
20	NC	Not connected.
Pkg Base	GND	Ground connection and heat sink.

Package Drawing

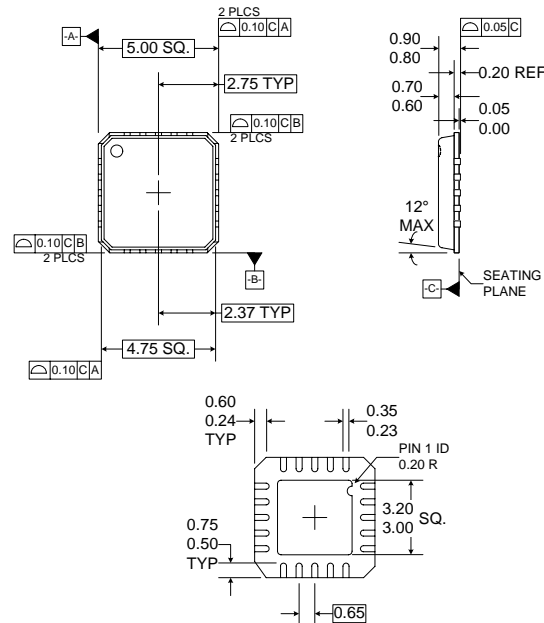

Dimensions in mm.

Evaluation Board Schematic

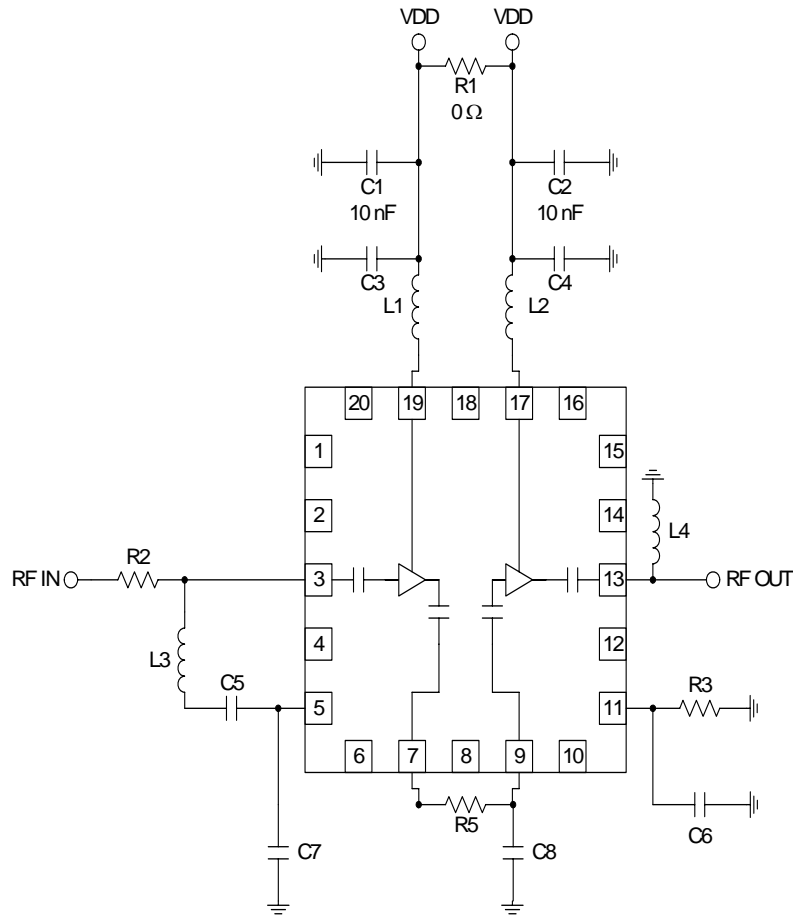

Components	700-1100 MHz	1.8-3.8 GHz
C3 (pF)	10	18
C4 (pF)	10	18
C5 (pF)	100	100
C6 (pF)	DNP	DNP
C7 (pF)	DNP	10
C8 (pF)	DNP	0.5
L1 (nH)	10	8.2
L2 (nH)	12	4.7
L3 (nH)	18	4.7
L4 (nH)	DNP	DNP
R2 (ohm)	0	0
R3 (ohm)	DNP	DNP
R5 (ohm)	10 pF	15 pF

R3 is DNP for standard 180mA current draw. If R3 is added, the I_{DD} will increase. A 20Ω R3 will raise the current to achieve higher linearity.

5V Noise Figure versus Temperature

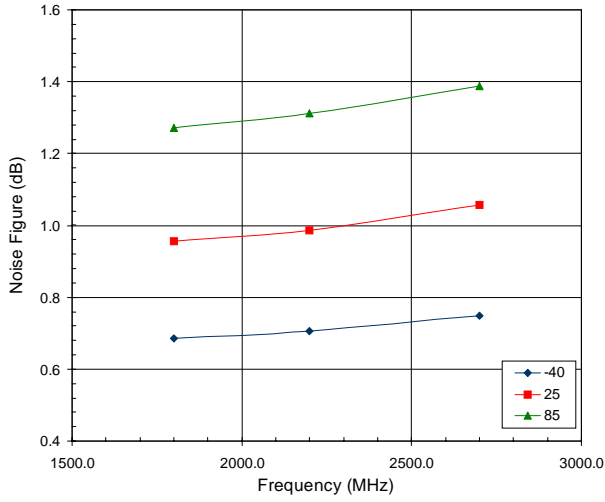

5V Gain versus Temperature

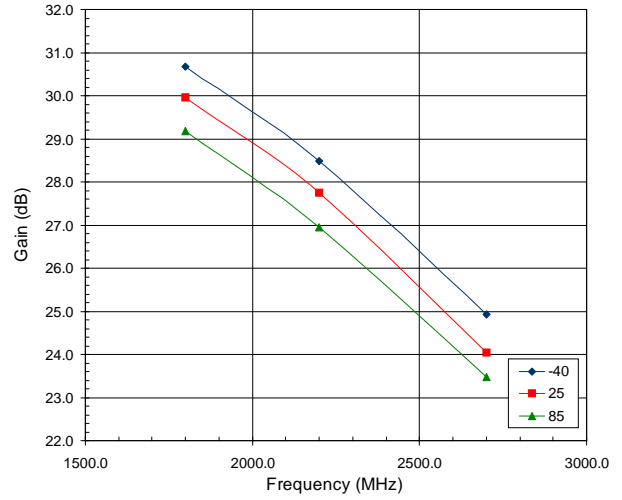

5V OIP3 versus Temperature

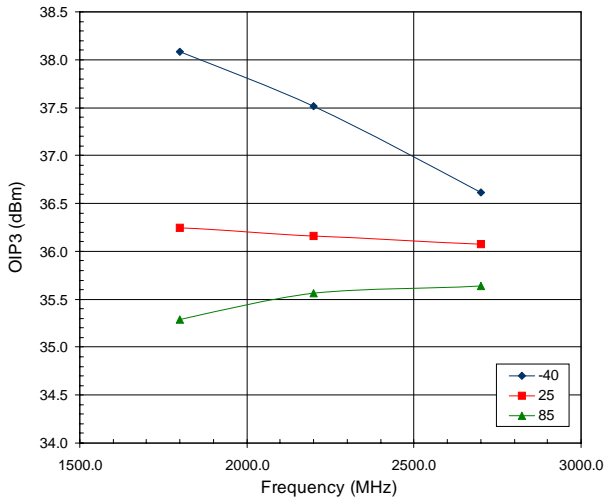

5V P1dB versus Temperature

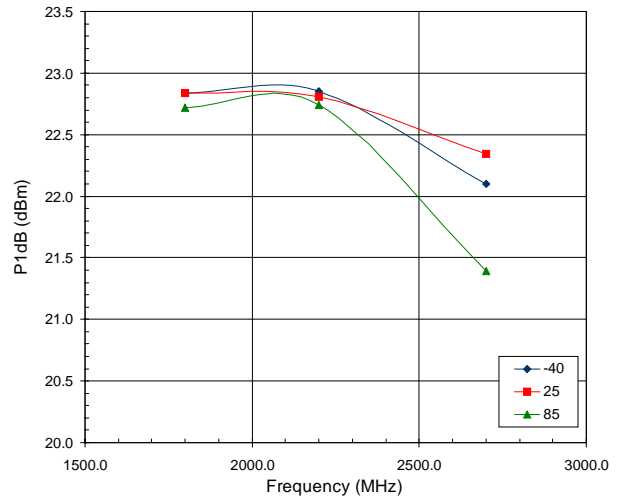

5V Noise Figure versus Temperature

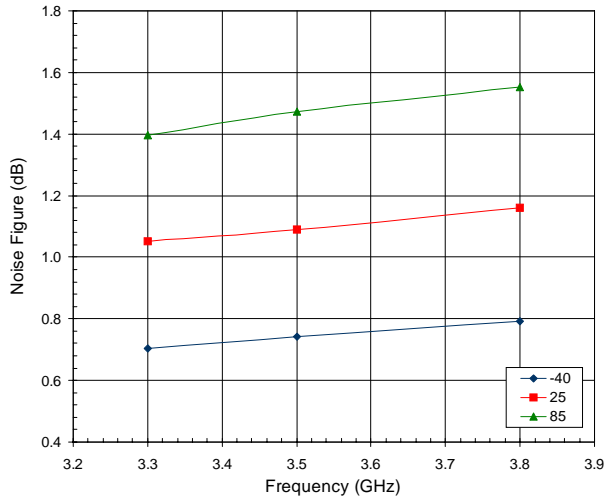

5V Gain versus Temperature

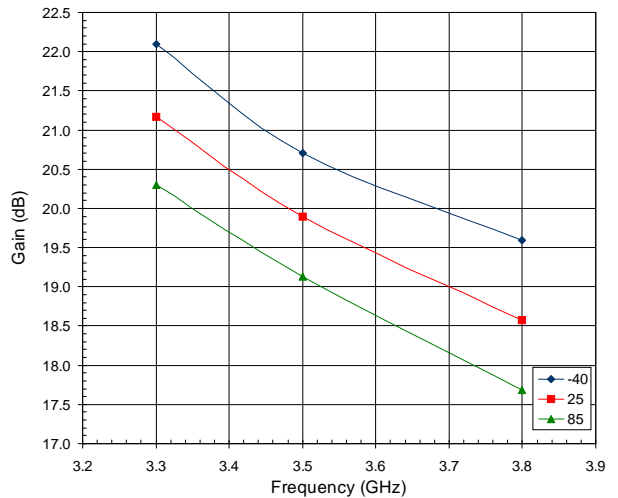

5V OIP3 versus Temperature

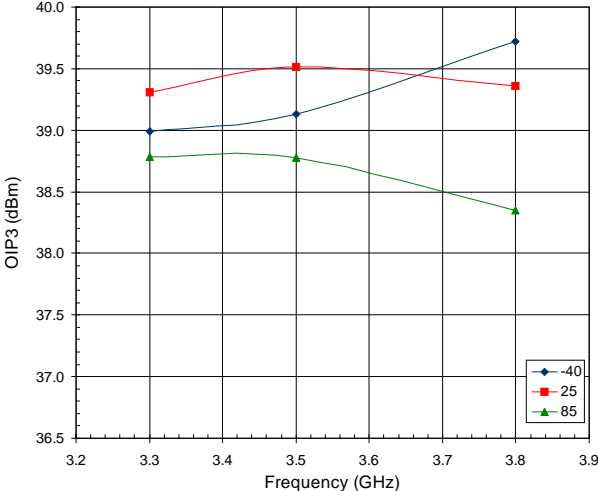

5V P1dB versus Temperature

