

INTRODUCTION

The S1A0292A01 is a monolithic integrated circuit consisting of a playback and record processing stereo amplifier, which is suitable for an audio system.

FEATURES

- 2CH Double input playback amplifier
- 2CH Recording Amplifier
- Built-in Recording Equalizer
- Tape selector
- ALC circuit
- Mute circuit
- Operating voltage ($V_{CC} = 6V - 12V$)

48-QFP-1010E

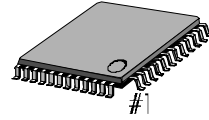

ORDERING INFORMATION

Device	Package	Operating Temperature	Pitch
S1A0292A01-Q1R0	48-QFP-1010E	-20°C - +70°C	0.8mm
		-20°C - +70°C	0.75mm

BLOCK DIAGRAM

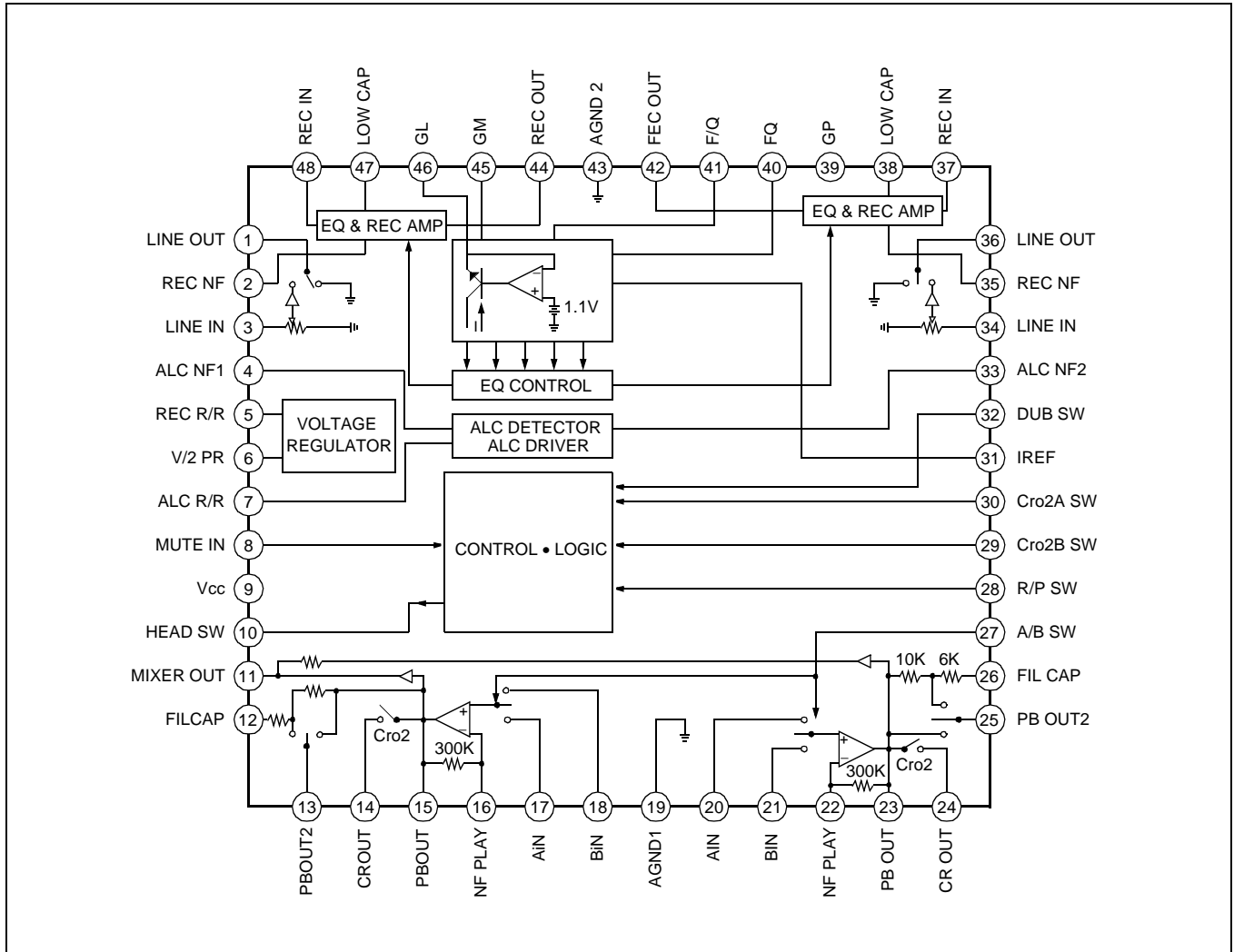

PIN DESCRIPTION

Pin Description

Pin No	Symbol	I/O	Description
1	LINE OUT(R)	OUTPUT	CCA (ALC Output) pin
2	NF REC	INPUT	Record amp feedback pin
3	LINE IN(R)	INPUT	Line input pin
4	ALC NF1	INPUT	ALC Amp feedback pin
5	REC R/R	–	Record ripple reject pin
6	VCC/2 R/R	–	Voltage reference ripple filter
7	ALC R/R	–	ALC time constant
8	MUTE IN	INPUT	Mute Signal (High Active (Input))
9	V _{CC}	V _{CC}	V _{CC}
10	HEAD SW	OUTPUT	Head switching DC output pin
11	MIXER OUT	OUTPUT	Playback mixer out
12	FILCAP(R)	–	HI-Speed filter capacitor
13	PB OUT-2(R)	OUTPUT	Playback output (for copy)
14	CROUT(R)	OUTPUT	Playback Cro2 feedback output
15	PB OUT-1(R)	OUTPUT	Playback tape out
16	NF PLAY	INPUT	Playback feedback input pin
17	A-IN(R)	INPUT	Playback A-Deck input pin
18	B-IN(R)	INPUT	Playback B-Deck input pin
19	AGND 1	GND	Play GND
20	A-IN(L)	INPUT	Playback A-Deck input pin
21	B-IN(L)	INPUT	Playback B-Deck input pin
22	NF PLAY(L)	INPUT	Playback feedback input pin
23	PB OUT-1 (L)	OUTPUT	Playback tape out
24	CROUT-2 (L)	OUTPUT	Playback Cro2 feedback output
25	PB OUT-2 (L)	OUTPUT	Playback output (for copy)
26	FILCAP (L)	–	HI-Speed filter capacitor
27	A.B-SW	INPUT	A-Deck (High Active) switch
28	R/P-SW	INPUT	Record (High Active) switch
29	Cro2B-SW	INPUT	Cro2-B-Deck (high active) switch
30	Cro2A-SW	INPUT	Cro2-A-Deck (high active) switch
31	IREF	–	EQ-BPF-IREF adjust

Pin Description (Continued)

Pin No	Symbol	I/O	Description
32	DUB-SW	INPUT	Normal (open) hi-speed (short)
33	ALC IN(L)	INPUT	ALC amp feedback pin
34	LINE IN(L)	INPUT	Line input pin
35	NF REC	INPUT	Record amp feedback pin
36	LIN OUT(L)	OUTPUT	CCA out
37	REC IN(L)	INPUT	Record input pin
38	LOWCAP(L)	–	REC equalizer low point capacitor
39	GP	–	REC equalizer gain control pin
40	FQ	–	REC equalizer q point control pin
41	F/Q	–	REC equalizer q & bw control pin
42	REC OUT(L)	OUTPUT	Record output pin
43	AGND2	–	REC gnd
44	REC OUT(R)	OUTPUT	Record output pin
45	GM	–	REC equalizer mid-gain control pin
46	GL	–	REC equalizer low-gain control pin
47	LOWCAP(R)	–	REC equalizer low point capacitor
48	REC IN(R)	INPUT	Record input pin

ABSOLUTE MAXIMUM RATING (Ta = 25°C)

Characteristic	Symbol	Value	Unit
Supply voltage	V _{CCQ}	12	V
Power dissipation	P _D	500	mW
Operating temperature	T _{OPR}	-20 – +70	°C
Storage temperature	T _{STG}	-50 – +125	°C

ELECTRICAL CHARACTERISTICS(V_{CC} = 9V, f = 1kHz, unless otherwise specified)

Characteristic		Symbol	Test conditions	Min.	Typ.	Max.	Unit
Quiescent circuit current		I _{CC}	REC MODE, V _I = 0	25	30	40	mA
PLAYBACK	Closed Loop Voltage Gain	G _{VC}	–	37	40	43	dB
	Maximum Output Voltage	V _{O1}	THD = 1% 0.71V _{rms}	0.7	1	–	V _{rms}
	Total Harmonic Distortion	THD ₁	V _O = 0dBm	–	0.1	0.5	%
	Cross Talk	CT ₁	V _{SG} = -40dBm	40	55	–	dB
	Muting Attenuation	ATT _{MUTE1}	V _{SG} = -40dBm	55	70	–	dB
ALC	ALC Voltage	V _{OCALCY}	V _{SG} = -20dB	28	35	45	mV _{rms}
	ALC Distortion	THD _{ALC}	V _{SG} = -20dB	–	0.3	1	%
	ALC Range	V _{ALC}	THD = 1% point up	25	32	–	dB
RECORD	EQ Low frequency Gain	E _{GH}	f = 50Hz/ – 40dB	29	33	37	dB
	EQ Mid Frequency Gain	E _{GM}	f = 500Hz/ – 40dB	21	25	29	dB
	EQ Peak Frequency Gain	E _{QP}	f = variable/ – 40dB	35	41	46	dB
	Maximum, Output Voltage	V _{O2}	THD = 1%	1	2	–	V _{rms}
	Record Switch Voltage	–	REC MODE	2.4	3.5	–	V
	Total Harmonic Distortion	THD ₂	V _O = 0dBm	–	0.5	1	%
	Cross Talk	CT ₂	V _{SG} = -40dBm	40	50	–	dB
	Muting Attenuation	ATT _{MUTE2}	V _{SG} = -40dB	55	70	–	dB

TEST CIRCUIT

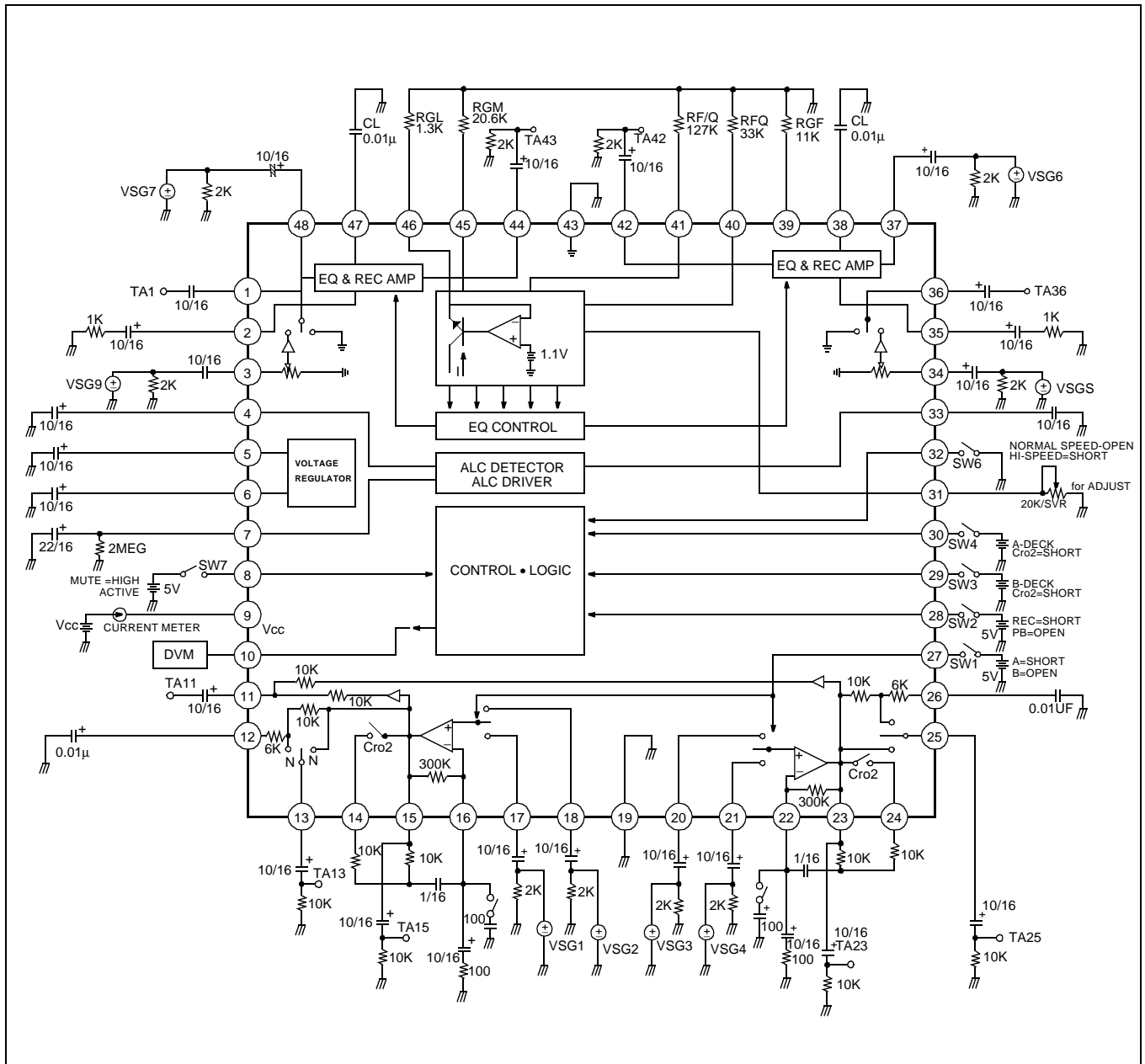

APPLICATION INFORMATION

1. FUNCTION SWITCH

- A/B SWITCH : A-DECK MODE = HIGH (5 V)
B-DECK MODE = OPEN (HIGH IMPEDANCE)
- *** On record mode, A-DECK is work only

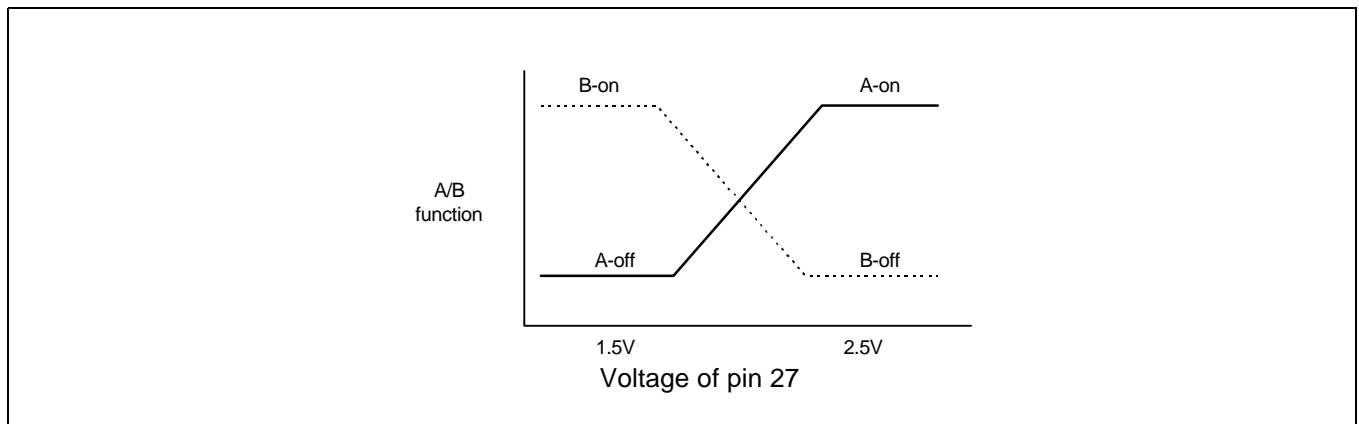

NOTE: The voltage of pin 27 is forced by a switch controller. If the voltage varies very fast from low to high, or high to low, then tape output makes a large pop noise.

To avoid this, we recommend slow switching.

- R/P SWITCH : REC MODE = HIGH (5 V)
PLAY MODE = OPEN (HIGH IMPEDANCE) OR GND
- Cro2B SWITCH : (B-DECK ONLY)
Cro2B PLAY = GND (0 V)
Cro2B OFF = OPEN (HIGH IMPEDANCE) OR V_{CC}
- Cro2A SWITCH : (A-DECK ONLY)
Cro2A PLAY = GND (0 V)
Cro2A OFF = OPEN (HIGH IMPEDANCE) OR V_{CC}
- DUBBING SWITCH : NORMAL SPEED TAPE EQUALIZING = OPEN (HIGH IMPEDANCE) OR V_{CC}
HIGH SPEED TAPE EQUALIZING = GND (0 V)
- MUTE SWITCH : MUTE ON = HIGH (5 V)
MUTE OFF = OPEN (HIGH IMPEDANCE) OR GND

2. RECORD EQUALIZER SETTING

This device has a frequency compensator, record equalizer circuit for boost, cut and a peak frequency that is used for tape recording.

Low and mid (about 30-3 kHz) frequency is fixed by the external capacitor C_L , and the gain is adjusted by two resistors that connect the R_{GM} and R_{GL} pins to the ground.

$$A_{HPF} = \frac{\frac{22000}{R_{GM}} S}{S + \frac{1}{R_{M3} * C_L}}$$

$$A_{LPF} = \frac{\frac{1}{R_{M3} * C_L}}{S + \frac{1}{R_{M3} * C_L}} \cdot \frac{8800}{R_{GL}}$$

$$R_{M3} = 10 \text{ K}, f_p = \frac{1}{2 * \pi * R_{M3} * C_L}, C_L = \text{external constant}$$

The Bode plot shows Gain on the vertical axis and frequency f on the horizontal axis. The gain is constant at low frequencies, then decreases linearly with a slope of -20 dB/decade in the mid-frequency region. At high frequencies, the gain increases linearly with a slope of +40 dB/decade, forming a peak. A dashed horizontal line indicates the gain level in the mid-frequency region.

Internal part R_{M3} and external C_L are fixed and R_{GM} is adjustable by means of the external. Hence, gain of mid and low frequency are controlled.

High frequency peaking function consisting of a 2nd order band pass filter, can adjust the band width, gain and peak frequency using the external resistor R_{GP} , R_{FQ} and $R_{F/Q}$.

$$A_{BPF} = \frac{\frac{K_1 G_1 G_{F/Q}}{C_{F/Q}} S}{S^2 + \frac{C_{F/Q}}{C_{F/Q}} S + \frac{K_2 G_{F/Q} G_{FQ}}{C_{F/Q} C_{FQ}}}, \quad \omega_0 = \sqrt{\frac{C_{F/Q} C_{FQ}}{C_{F/Q} C_{FQ}}}, \quad Q = \frac{C_{F/Q}}{C_{F/Q}} \sqrt{\frac{C_{F/Q}}{C_{F/Q} C_{FQ}}}, \quad G_{PF} = K_1 G_1$$

$$G_1 = \frac{4.4}{R_{GP}}, \quad G_{F/Q} = \frac{1}{15K} * \frac{2R_{IREF}}{R_{F/Q}}, \quad G_{FQ} = \frac{1}{15K} * \frac{R_{IREF}}{R_{F/Q}},$$

$$K_1 = 40e4, \quad K_2 = 1, \quad G_{F/Q} = 160pF, \quad C_{F/Q} = 70pF$$

We have shown that R_{IREF} is a semi-fixed resistor, which compensates internal capacitors for variations of the fabric process.

Constant K is a gain to be fixed but K_5 is variable. Only K_5 can be used to adjust the final record gain.

$$GEQ = K_5 (K_3 G_{BPF} + A_{HPF})$$

$$K_3 = 0.5, K_4 = 0.5$$

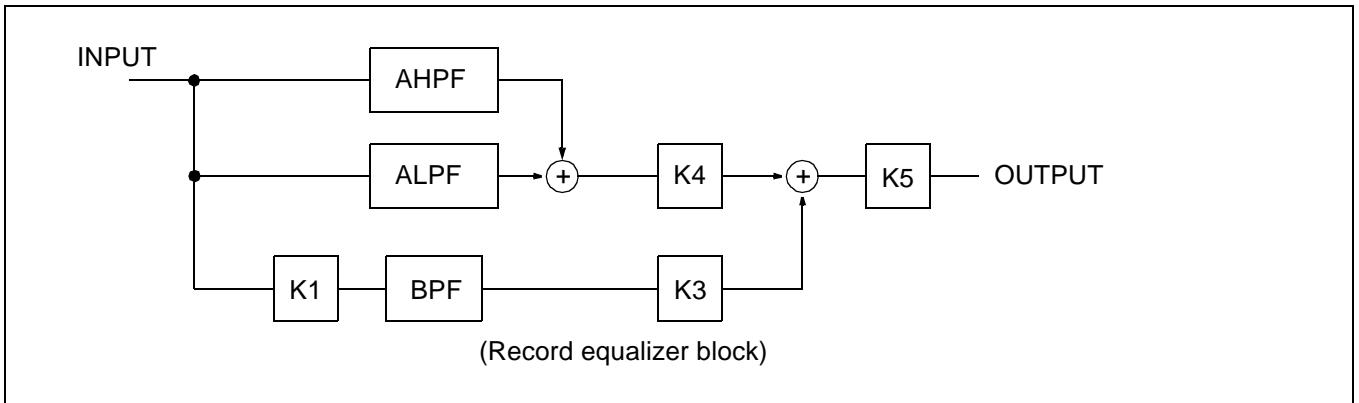

If K_5 is 10, the record maximum output level is 1 Vrms and the output noise is 0.8 mVrms. We recommend that you keep it between 10 and 20 if possible.

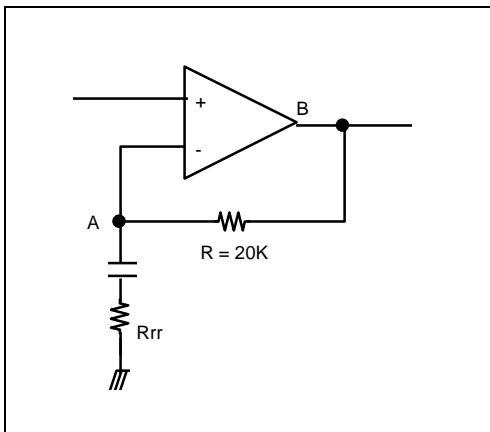

Point A is pin 2 and pin 35, B is pin 44 and pin 42.
 K_5 , close loop gain, is R/R_{rr} .

We must connect R_{GP} , $R_{F/Q}$, R_{GL} and R_{GM} to the ground.

- R_{GP} = PIN39
- FQ = PIN40
- $R_{F/Q}$ = PIN41
- R_{GM} = PIN45
- R_{GL} = PIN46
- R_{IREF} = PIN31
- C_L = PIN38, PIN47

3. CONNECTION FOR PARAMETERS

For varying the record frequency response, we must connect the external resistor. In the following figure, current flows from transistor through resistor. As we know, the current is defined as $(1.2 \text{ V}-1 \text{ VBE})/R$, amount of this current influence for G_m (transconductance amplifier transfer ratio).

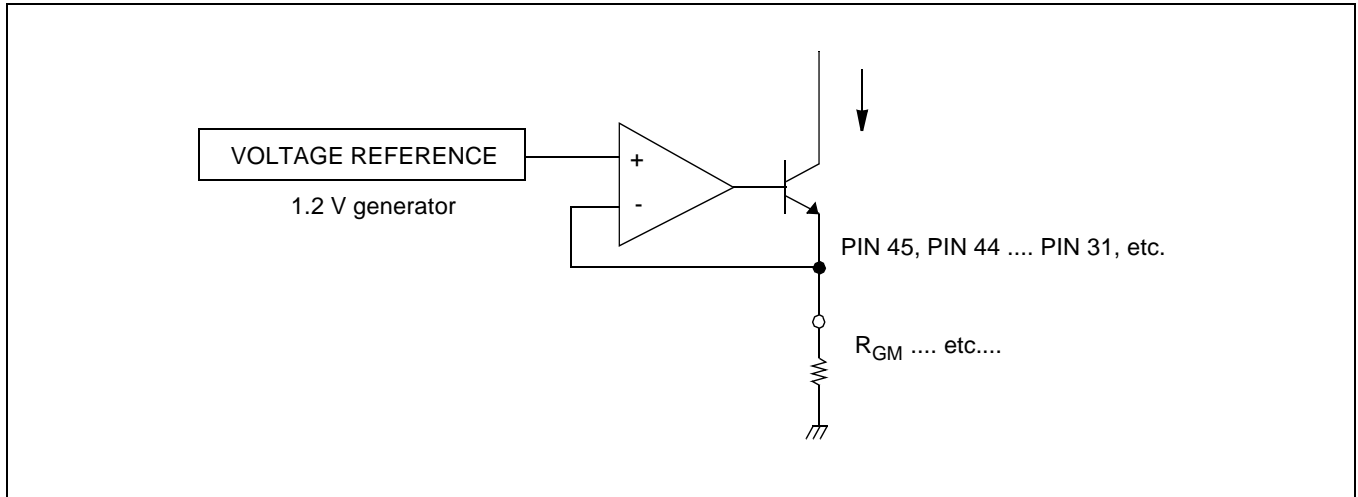

Method of connection: connect the control pins to ground.

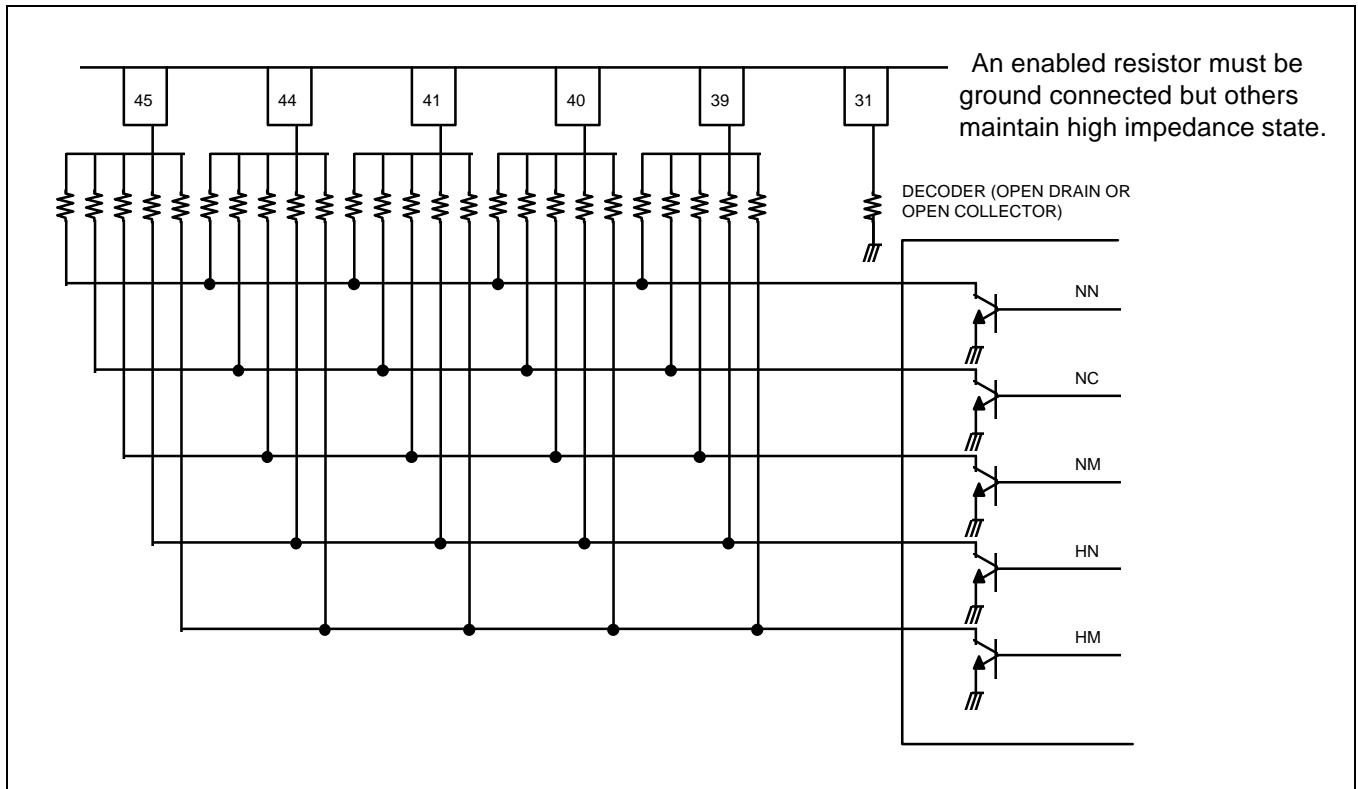

4. ALC LEVEL ADJUSTMENT

This device is built so that the automatic level control circuit has a fixed level, but the user can adjust it to be larger

than the fixed level. The design is fixed to 35 mVrms, but adding an external part will change that to a higher level of 1 Vrms, level and range is shown in the following figure. The user may align it to his/her own needs.

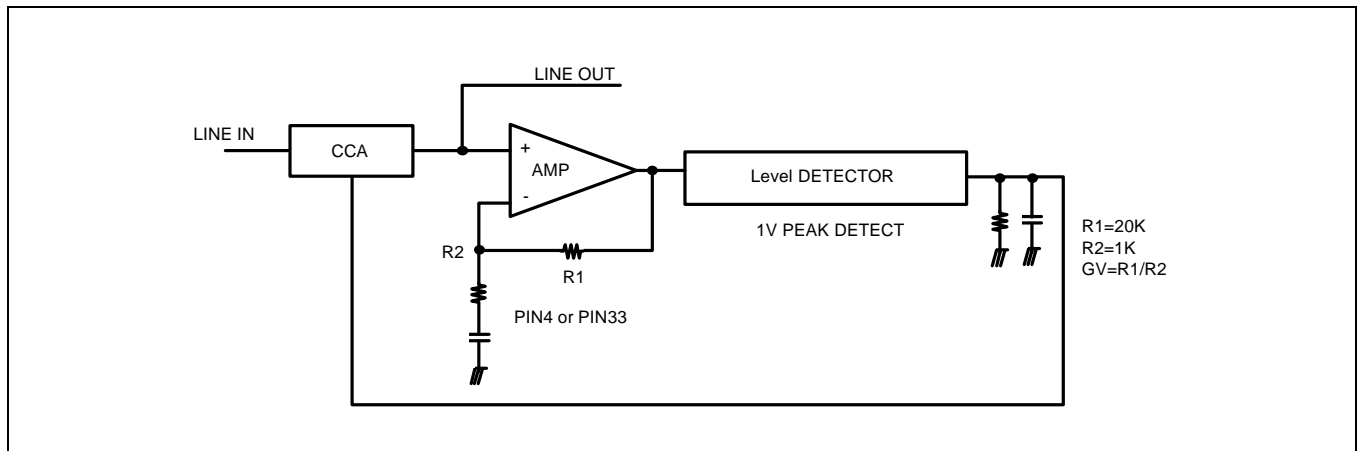

The ALC out level, LINE OUT level is defined as

$$\text{ALC OUT} = \frac{1}{GV} \cdot 2 \cdot \frac{1}{2\sqrt{2}} = 35 \text{ mVrms}$$

To change GV, add a resistor that means at pin 4 or pin 33 as shown.

5. PERIPHERAL OF PLAYBACK AMP

1) NAB elements

$$H_{NAB}(S) = \frac{1}{S + \frac{R_2}{R_3} C_1} \cdot \frac{1}{S + (R_1 + R_2) C_1}$$

$RZ = R_2/R_3$: Cro MODE
 RZ : NORMAL MODE

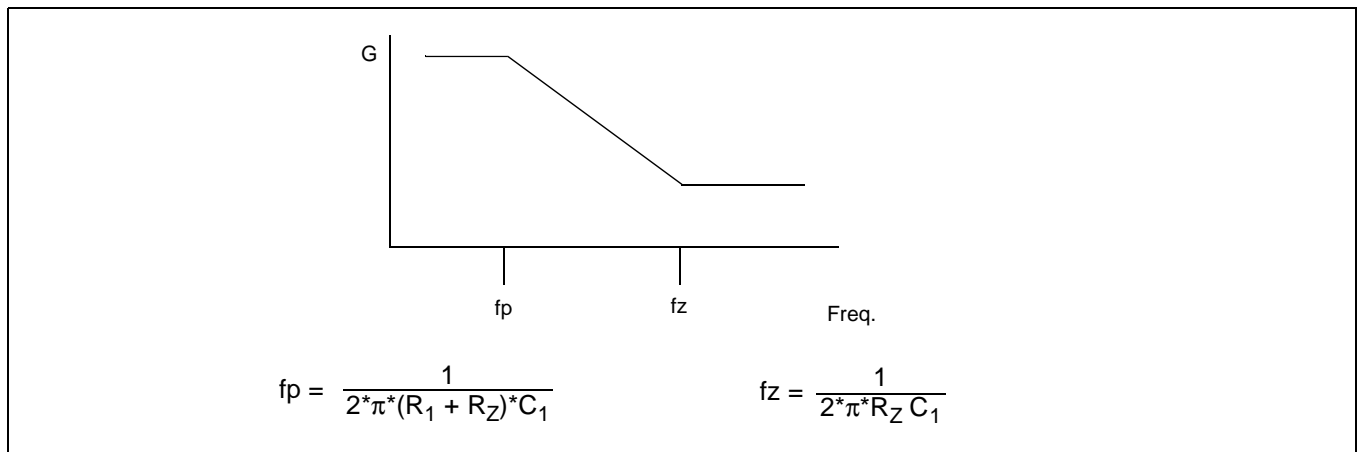
$$GPB(S) = H_{NAB}(S) * \frac{R_1 R_2}{(R_1 + R_2) R_4} \cdot \frac{1}{R_4} \cong H_{NB}(S) * \frac{RZ}{R_4}$$

2) High speed dubbings cutting function is defined R5, R6, C2

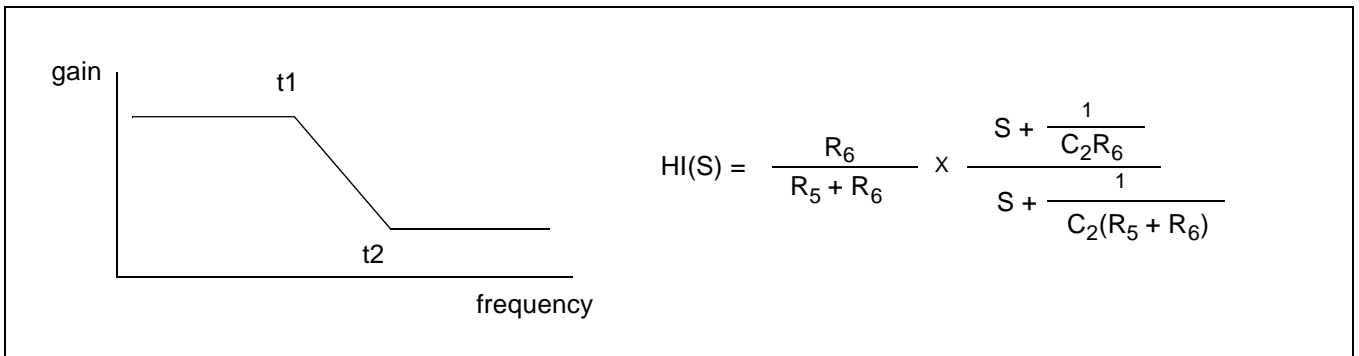

APPLICATION CIRCUIT

