

LVC MOS SC-B1440 Series

Rev. -

Description

The **SC-B1440 Series** of quartz crystal oscillators provide enable/disable 3-state LVC MOS compatible signals for bus connected systems. Supplying Pin 1 of the SC-B1440 units with a logic "1" or open enables its Pin 3 output. In the disable mode, Pin 3 presents a high impedance to the load.

Features

- Wide frequency range—220.0MHz to 250.0MHz (Contact factory for other frequencies)
- User specified tolerance available
- Will withstand vapor phase temperatures of 253°C for 4 minutes maximum
- Space-saving alternative to discrete component oscillators
- 2.5 Volt operation
- High shock resistance, to 1000g
- Low Jitter - Wavecrest jitter characterization available
- High Reliability - NEL HALT/HASS qualified for crystal oscillator start-up conditions
- High Q Crystal actively tuned oscillator circuit
- Power supply decoupling internal
- No internal PLL avoids cascading PLL problems
- High frequencies due to proprietary design
- Metal lid electrically connected to ground to reduce EMI
- Gold plated pads
- RoHS Compliant, Lead Free Construction

Electrical Connection

Pin	Connection
1	Enable/Disable
2	Ground
3	Output
4	V _{DD}

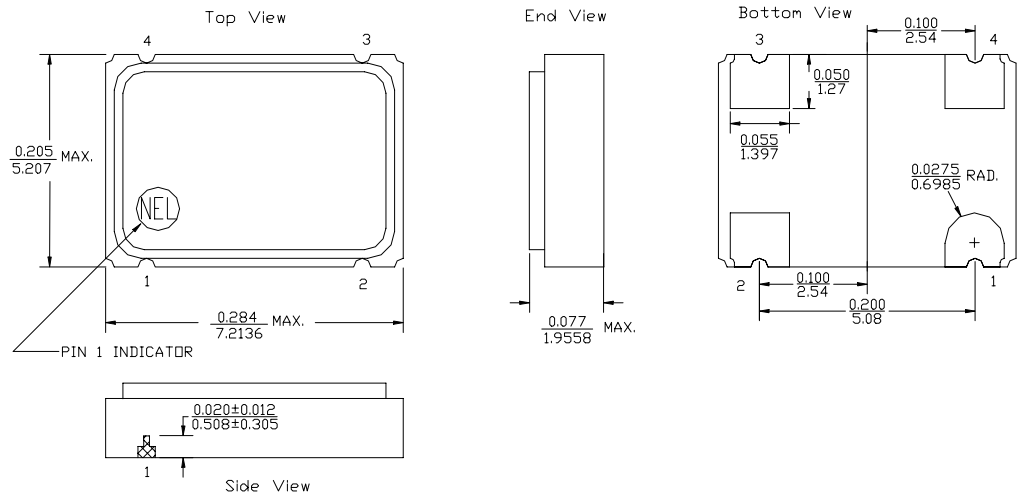

ALL DIMENSIONS: $\frac{\text{IN}}{\text{mm}}$
All tolerances are ±0.005 inches (±0.127 mm) unless otherwise specified.

SC-B1440 Series Continued
LVCMOS

Rev. -

Operating Conditions and Output Characteristics

Electrical Characteristics

Parameter	Symbol	Conditions	Min	Typical	Max
Frequency	-----	-----	220.0MHz	-----	250.0MHz
Duty Cycle	-----	@ $V_{DD}/2$	45/55%	-----	55/45%
Logic 0	V_{OL}	@ 600 μ A	-----	-----	0.2V
Logic 1	V_{OH}	@ 600 μ A	$V_{DD}-0.2V$	-----	-----
Rise & Fall Time	tr,tf	10-90% V_O	-----	-----	2.0 ns
Jitter, RMS ⁽²⁾	-----	Overtone	-----	-----	3 psec
T_{pz}	-----	-----	-----	-----	100 ns
Enable Voltage	-----	-----	1.6V	-----	-----
Disable Voltage	-----	-----	-----	-----	0.4V
Frequency Stability ⁽¹⁾	dF/F	Overall conditions including: voltage, calibration, temp., 10 yr aging, shock, vibration	-100ppm	-----	+100ppm

General Characteristics

Parameter	Symbol	Conditions	Min	Typical	Max
Supply Voltage ⁽³⁾	V_{DD}	-----	2.375V	2.5V	2.625V
Supply Current	I_{DD}	No Load	0.0 mA	85 mA	110 mA
Output current	I_O	Low level Output Current	0.0 mA	-----	± 25.0 mA
Operating temperature	T_A	-----	0°C	-----	70°C
Storage temperature	T_S	-----	-55°C	-----	125°C
Power Dissipation	P_D	-----	-----	-----	158 mW
Lead temperature	T_L	Soldering, 10 sec.	-----	-----	300°C
Load	-----	-----	-----	-----	15pf
Start-up Time	t_s	-----	-----	-----	10 ms

Environmental and Mechanical Characteristics

Mechanical Shock	Per MIL-STD-202, Method 213, Condition E
Thermal Shock	Per MIL-STD-833, Method 1011, Condition A
Vibration	0.060" double amplitude 10 Hz to 55 Hz, 35g's 55Hz to 2000 Hz
Soldering Condition	300°C for 10 seconds
Hermetic Seal	Leak rate less than 1×10^{-8} atm.cc/sec of helium

Footnotes:

- 1) Standard frequency stability ($\pm 20, \pm 25, \pm 50$ ppm & others available)
- 2) Jitter performance is frequency dependent. Please contact factory for full Wavecrest characterization. RMS jitter bandwidth of 12kHz to 20MHz.
- 3) Internal high frequency power source decoupling.

Creating a Part Number	
SC - B144X - FREQ	
Package Code	Tolerance/Performance
SC 4 pad 5x7mm SMD	0 ± 100 ppm 0-70°C
	1 ± 50 ppm 0-70°C
	7 ± 25 ppm 0-70°C
	9 Customer Specific
Input Voltage	A ± 20 ppm 0-70°C
Code Specification	B ± 50 ppm -40 to +85°C
A 3.3V	C ± 100 ppm -40 to +85°C
B 2.5V	
5V	

Test Load:

