

REMOTE CONTROL ENCODER

DESCRIPTION

The SC5260 is a remote control encoder paired with either SC5260 or SC5272 utilizing COMS Technology. It encodes data and address pins into a serial coded waveform suitable for RF modulation. SC5260 has a maximum of 10 bits tri-state address pins providing up to 59,049 (or 310) address codes; thereby, drastically reducing any code collision and unauthorized code scanning possibilities.

SC5260 is one of the first generation of Encoder/Decoder ICs. When paired with SC5270, this encoder/decoder (SC5260/SC5270) pair can operate at very wide temperature range (see Features). Thus, this very important feature enables your Encoder/Decoder to operate under the worst environmental condition.

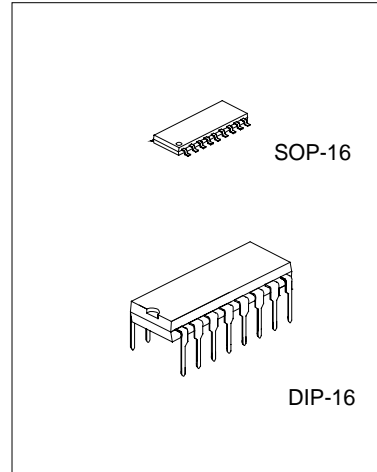

FEATURES

- * High Performance Technology
- * Low Power Consumption
- * Very High Noise Immunity
- * Wide Operating Temperature Range: -30°C ~ 70°C
- * 8 or 10 Tri-State Code Address Pins
- * Single Resistor Oscillator
- * Least External Components

APPLICATIONS

- * Home/Car Security System
- * Garage Door Controller
- * Remote Fan Controller
- * Remote Control Toys

ODERING INFORMATION

SC5260-R4 (S)	16 Pins, DIP (SO)
SC5260-R2 (S)	16 Pins, DIP (SO)

BLOCK DIAGRAM

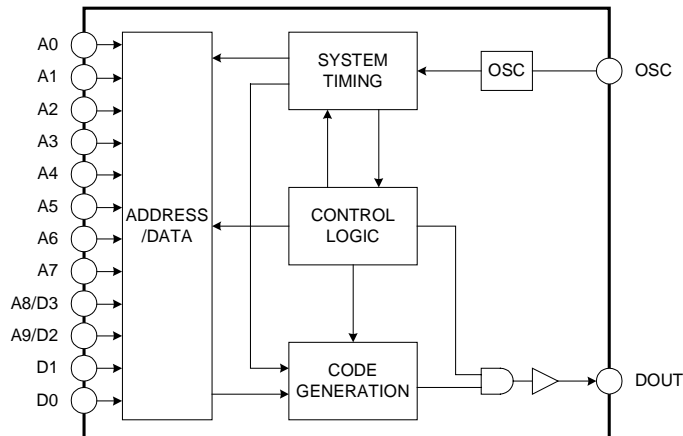

PIN CONFIGURATION

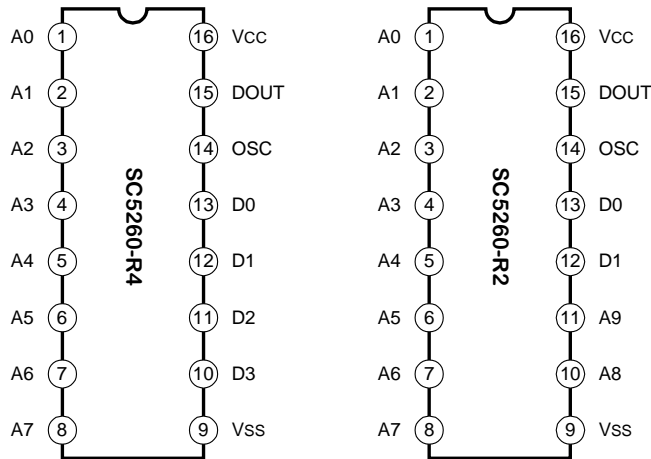

ABSOLUTE MAXIMUM RATINGS

Characteristic	Symbol	Value	Unit
Supply Voltage	V _{CC}	-0.3 ~ +6.0	V
Input/Output Voltage	V _{IN} , V _{OUT}	-0.3V ~ V _{CC} +0.3V	V
Maximum Power Dissipation	P _a	500	mW
Operating Temperature	T _{opr}	-30 ~ +70	°C
Storage Temperature	T _{stg}	-40 ~ +125	°C

— HANGZHOU SILAN MICROELECTRONICS JOINT-STOCK CO.,LTD —

Rev: 1.0 2000.12.31

ELECTRICAL CHARACTERISTICS

Parameter	Symbol	Test conditions	Min	Typ	Max	Unit
Supply Voltage	VCC		1.8		6.0	V
Stand-by Current	I _{sb}	VCC=3V OSC stops All input pins open	0.2	0.5	0.8	μA
DOUT Output Driving Current	I _{OH}	VCC=3V, V _{OH} =1.5V VCC=6.0V, V _{OH} =3.0V	2.5 10			mA
DOUT Output Sinking Current	I _{OL}	VCC=3V, V _{OH} =1.5V VCC=6.0V, V _{OH} =3.0V	4.6 12			mA
Operation Current	I _{op}	VCC=1.8V VCC=6.0V	0.01 0.50			mA

PIN DESCRIPTION

Pin No.	Symbol	I/O	Description
1~8	A0~A7	I	Code Address Pin Nos.0~7 These eight tri-state pins are detected by SC5260 to determine the encoded waveform bit0-bit7. Each bit can be set to "0", "1", or "f"(floating).
10~11	A8/D3~A9/D2	I/PL*	Code Address pin Nos.8~9/Data Pin Nos.3~2. These two tri-state pins are detected by SC5260 to determine the encoded waveform bit8-bit9. When these pins are used as address pins (as in SC5260-R2), they can be set to "0", "1", or "f" (floating). When these pins are used as data pins (as in SC5260-R4), they can only be set to "0" or "1".
12~13	D1, D0	I/PL	Data Pin Nos. 1~0. These pins can only be set to "0" or "1".
14	OSC	I	Oscillator Pin A resistor connected between the OSC Pin and the VCC determines the fundamental frequency of the SC5260.
15	DOUT	O	Data Output Pin. The encoded waveform is serially outputted to this pin. When SC5260 is not transmitting, DOUT outputs low (VSS) voltage.
16	VCC		Positive Power Supply
9	VSS		Negative Power Supply

Note: PL -- Pull-low Resistor is connected internally

PL* -- If those two pins are used as Data Pins (SC5260-R2), pull-low resistor is connected internally;
otherwise, no pull-low resistor is connected.

FUNCTIONAL DESCRIPTION

SC5260 encodes the code address and data set at A0~A7, A8/D3, A9/D2, D1 and D0 into a special waveform and outputs it to the DOUT when any of the data pins is tied to high. This waveform is fed to the RF Modulator for transmission. The transmitted radio frequency is received by the RF demodulator and reshaped into the special waveform. SC5270 (or SC5272) is then used to decode the waveform and set the corresponding output pin(s). Thus completing a remote control encoding and decoding function.

1. RF Operation

1) Code Bits

A Code Bits is the basic component of the encoded waveform, and can be classified as either an *AD (Address/Data) Bit* or a *SYNC (Synchronous) Bit*.

•*Address/Data (AD) Bit Waveform*

An AD Bit can be designated as Bit "0", "1", or "f" if it is in low, high or floating state respectively. One bit waveform consists of 2 pulse cycles. Each pulse cycle has 512 oscillating clock periods. For further details, please refer to the diagram below:

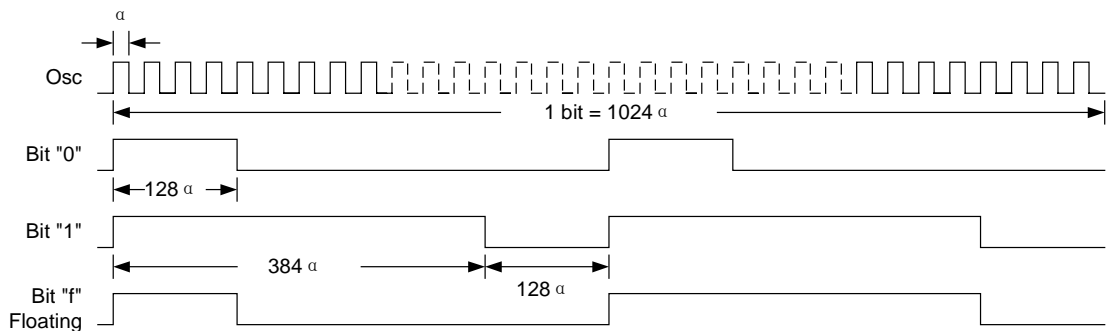

Where: α = Oscillating Clock Period

•*Synchronous (SYNC.) Bit Waveform*

The Synchronous Bit Waveform is 4 bits long with 1/8 bit width pulse. Please refer to the diagram below:

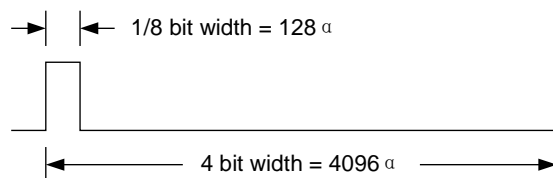

Note: 1 bit = 1024α

2) Code Word

A group of Code Bits is called a Code Word. A Code Word consists of 12 AD bits followed by one Sync Bit. The 12 AD bits are determined by the corresponding states of A0~A7, A8/D3, A9/D2, D1 and D0 pins at the time of transmission. When the Data Type of SC5260 is used, the address bits will decrease accordingly.

For example: In the 4-Data Type where the address has eight (8) bits, the transmitting format is:

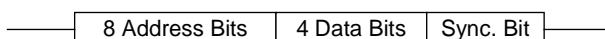

SC5260 has a maximum of ten (10) Address Bits. The following diagram shows the code bits with their corresponding pins.

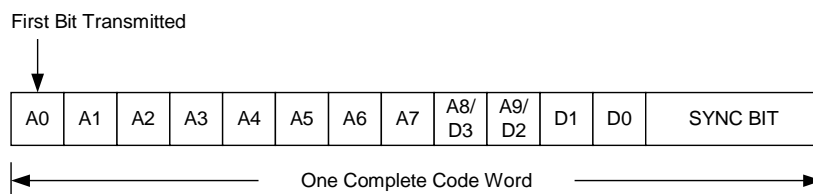

2 Data:	A0	A1	A2	A3	A4	A5	A6	A7	A8	A9	D1	D0	Sync Bit
4 Data:	A0	A1	A2	A3	A4	A5	A6	A7	D3	D2	D1	D0	Sync Bit

The Code Bits A0~A7, A8/D3, A9/D2, D1 and D0 are determined by the states set at these pins. For example, when the A0 (Pin No.1) is set to "1" (VCC), the Code Bit A0 is synthesized as "1" bit. In the same manner, when it (A0 Pin) is set to "0" (VSS) or left floating, the Code Bit A0 is synthesized as a "0" or "f" bit respectively.

When SC5260 detects "1" on any of the Data Pins, it outputs a Code Word at DOUT. If the Data Pin is still in high state ("1") the time the Code Word transmission ends, SC5260 outputs the same Code Word. Please refer to the diagram below:

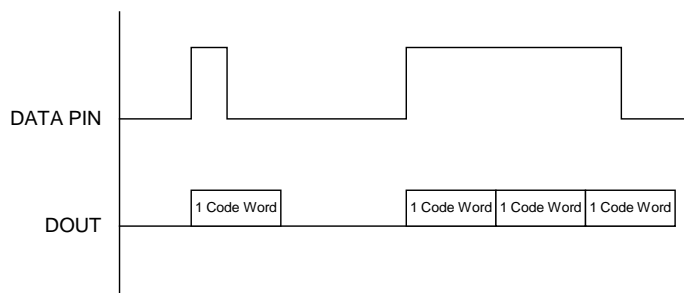

3) Single Resistor Oscillator

The built-in oscillator circuitry of SC5260 allows a precision oscillator to be constructed by connecting an external resistor between OSC and VCC pins. For SC5270 (or SC5272) to decode correctly the received waveform, the oscillator frequency of SC5270 (or SC5272) must be 1/16~4 (or 1/16~1/4) times that of the transmitting SC5260. The typical oscillator frequency of SC5270, and SC5272 are shown below:

Encoder (SC5260) OSC Frequency

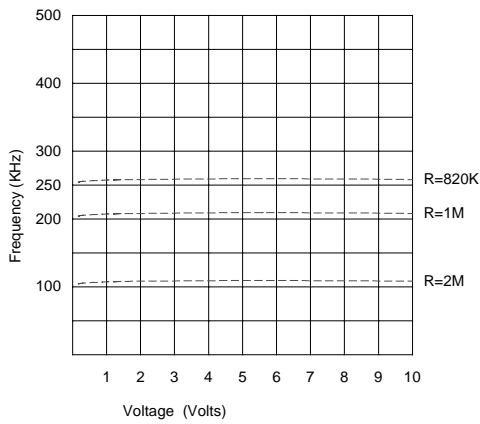

Decoder (SC5270) OSC Frequency

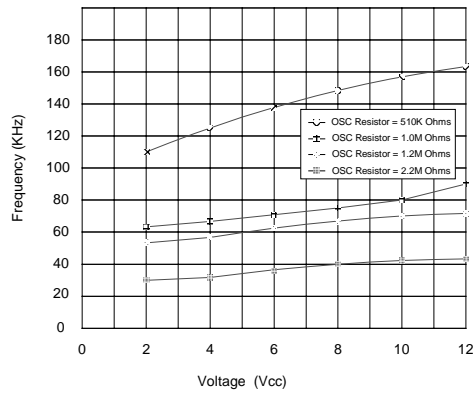

Decoder (SC5272) OSC Frequency

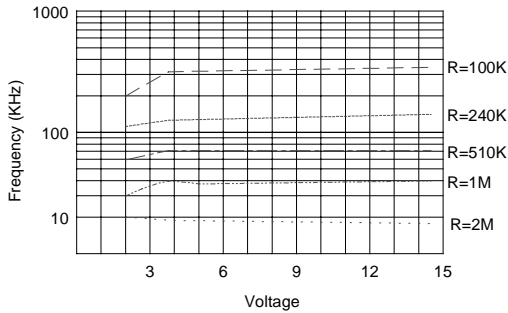

Suggested oscillator resistor values are shown below.

SC5260	SC5270	SC5272
820kΩ	510kΩ	1MΩ
1MΩ	620kΩ	1.2MΩ
2MΩ	1.2MΩ	2.2MΩ

OPERATION FLOWCHART

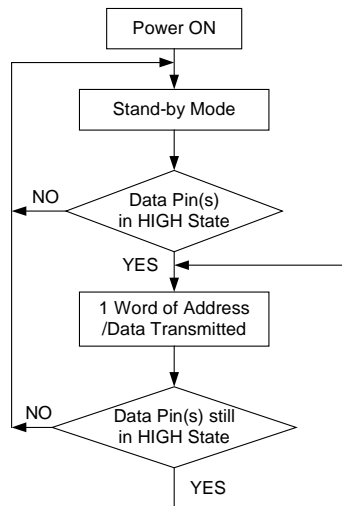

APPLICATION CIRCUIT

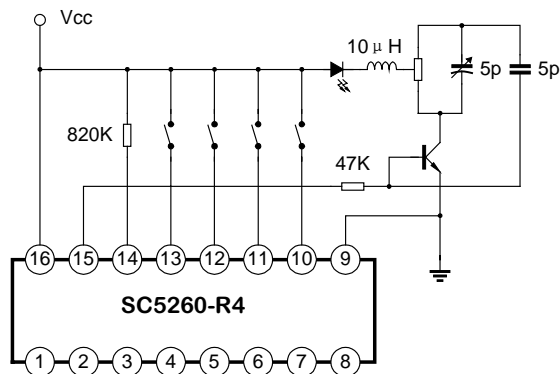

PACKAGE OUTLINE

