

SH8G41

FOR AUTOMATIC-STROBE FLASHER APPLICATIONS
 --- DISCHARGER (Chopper)

- Type No. SH8G41 is Designed for a Small Package Device Having Shorted Turn-Off Time and Low Turn-On Loss at High Current.
- Repetitive Peak Off-State Voltage and Peak Reverse Voltage : $V_{DRM} = V_{RRM} = 400V$
- Repetitive Peak Surge On-State Current : $I_{TRM} = 350A$
- Critical Rate of Rise of On-State Current : $di/dt = 100A/\mu s$
- Plastic Mold Package

MAXIMUM RATINGS

CHARACTERISTIC	SYMBOL	RATING	UNIT
Repetitive Peak Off-State and Reverse Voltage	V_{DRM} V_{RRM}	400	V
Non-Repetitive Peak Reverse Voltage (Note 1)	V_{RSM}	450	V
Repetitive Peak Surge On-State Current (Note 2)	I_{TRM}	350	A
Critical Rate of Rise of On-State Current (Note 3)	di/dt	100	A / μs
Peak Gate Power Dissipation	P_{GM}	5	W
Average Gate Power Dissipation	$P_G (AV)$	0.5	W
Peak Forward Gate Current	I_{GM}	2	A
Junction Temperature	T_j	-40~125	°C
Storage Temperature Range	T_{stg}	-40~125	°C

Note 1: Non - Rep. < 5ms, $T_j = 0\sim 125^\circ C$

Note 2: $C_M = 1000\mu F$

Note 3: $i_G = 100mA$

$t_{gw} = 10\mu s$

$t_{gr} \leq 250ns$

Unit: mm

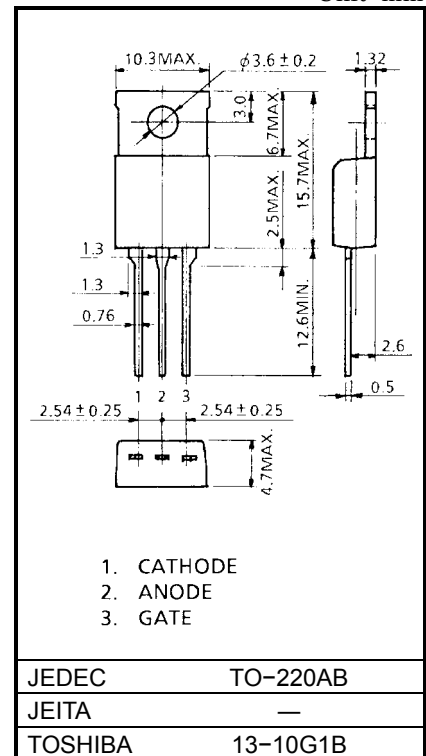

Weight: 2.0g

ELECTRICAL CHARACTERISTICS (Ta = 25°C)

CHARACTERISTIC	SYMBOL	TEST CONDITION	MIN	MAX	UNIT
Repetitive Peak Off-State and Reverse Current	I_{DRM} I_{RRM}	$V_{DRM} = V_{RRM} = 400V$	—	250	μA
Peak On-State Voltage	V_{TM}	$I_{TM} = 25A$	—	2.3	V
Gate Trigger Voltage	V_{GT}	$V_D = 6V, R_L = 10\Omega$	—	1.5	V
Gate Trigger Current	I_{GT}		—	50	mA
Gate Non-Trigger Voltage	V_{GD}	$V_D = 200V, T_a = 125^\circ C$	0.2	—	V
Holding Current	I_H	$R_L = 100\Omega$	—	150	mA
Commutating Capacitor	C_c	$C_M = 1000\mu F, V_{CM} = 350V, I_{TM} = 230A$ $L_M = 50\mu H, V_{GR} = -6V$	—	2.7	μF
Thermal Resistance	$R_{th(j-a)}$	Junction to Ambient	—	90	$^\circ C / W$

MARKING

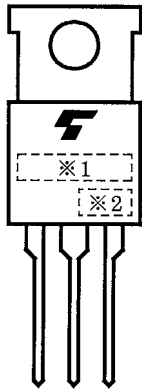

NUMBER	SYMBOL		MARK
*1	TYPE	SH8G41	SH8G41
*2	<p>Lot Number</p> <p>Month (Starting from Alphabet A)</p> <p>Year (Last Decimal Digit of the Current Year)</p>		<p>Example</p> <p>8A : January 1998</p> <p>8B : February 1998</p> <p>8L : December 1998</p>

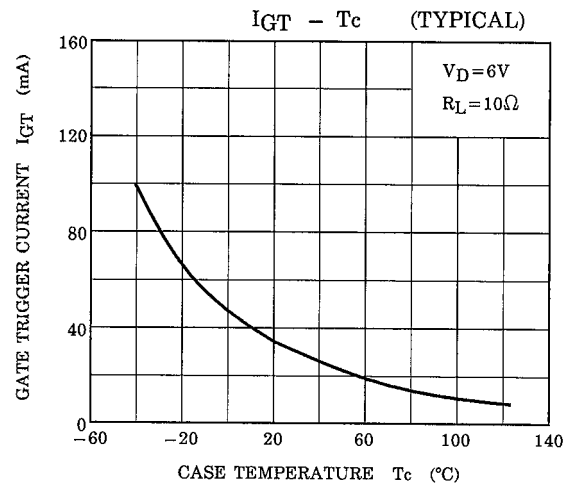
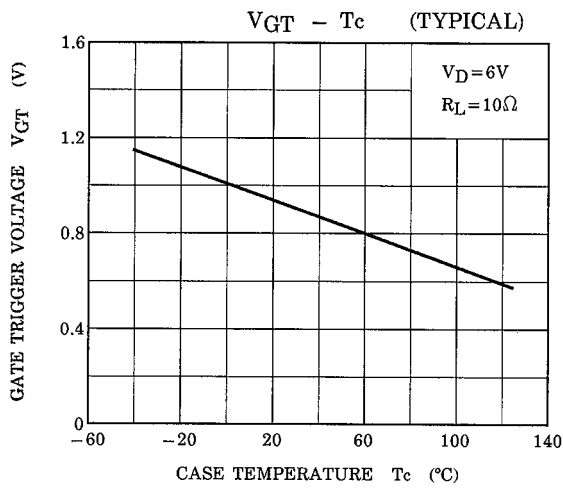
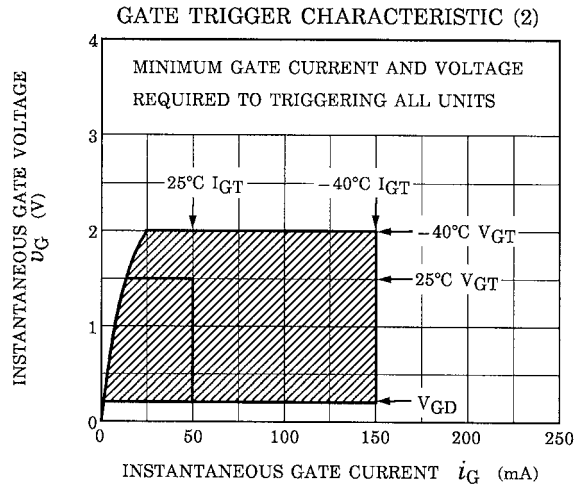
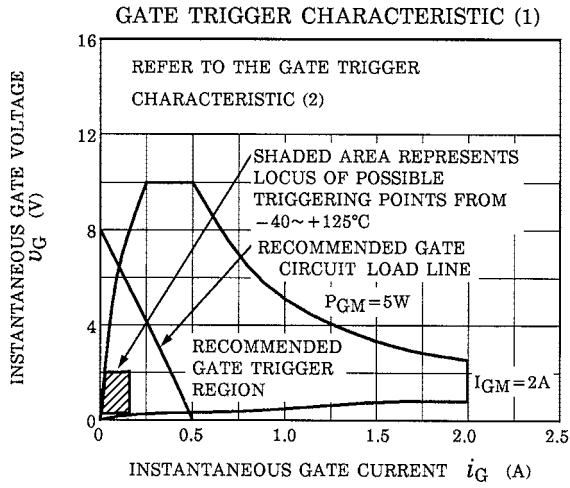

COMMUTATING CIRCUIT AND CONDITION

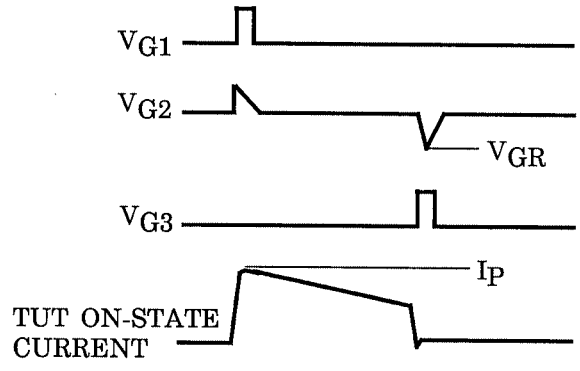
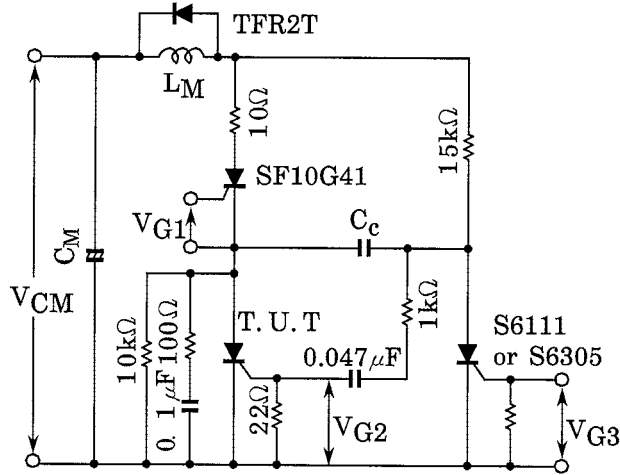

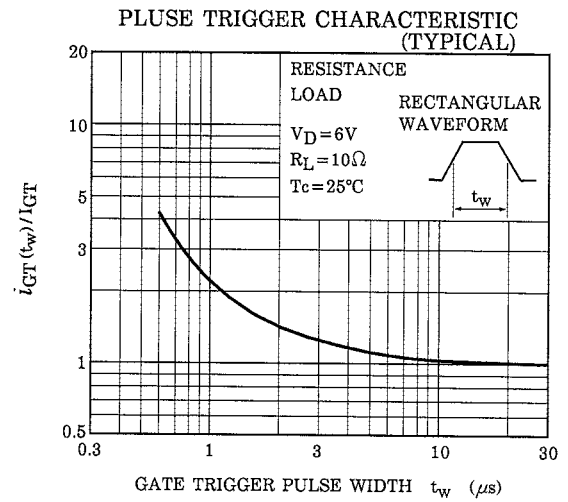
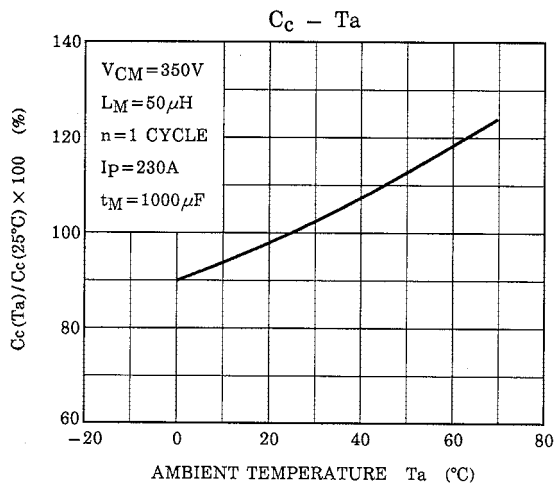
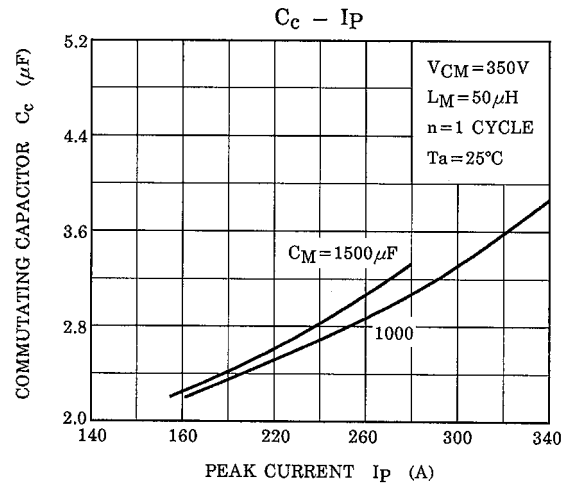
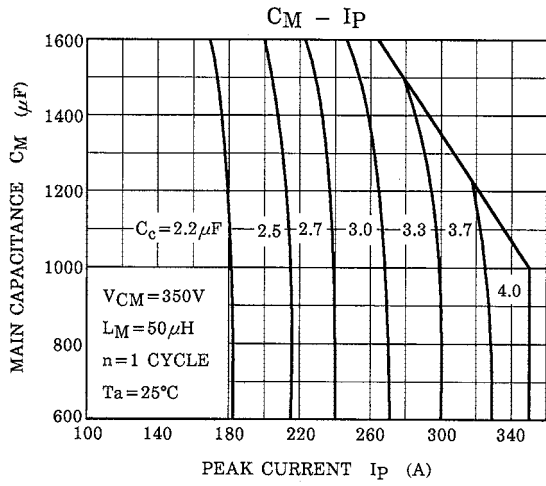

RESTRICTIONS ON PRODUCT USE

000707EAA

- TOSHIBA is continually working to improve the quality and reliability of its products. Nevertheless, semiconductor devices in general can malfunction or fail due to their inherent electrical sensitivity and vulnerability to physical stress. It is the responsibility of the buyer, when utilizing TOSHIBA products, to comply with the standards of safety in making a safe design for the entire system, and to avoid situations in which a malfunction or failure of such TOSHIBA products could cause loss of human life, bodily injury or damage to property.
In developing your designs, please ensure that TOSHIBA products are used within specified operating ranges as set forth in the most recent TOSHIBA products specifications. Also, please keep in mind the precautions and conditions set forth in the "Handling Guide for Semiconductor Devices," or "TOSHIBA Semiconductor Reliability Handbook" etc..
- The TOSHIBA products listed in this document are intended for usage in general electronics applications (computer, personal equipment, office equipment, measuring equipment, industrial robotics, domestic appliances, etc.). These TOSHIBA products are neither intended nor warranted for usage in equipment that requires extraordinarily high quality and/or reliability or a malfunction or failure of which may cause loss of human life or bodily injury ("Unintended Usage"). Unintended Usage include atomic energy control instruments, airplane or spaceship instruments, transportation instruments, traffic signal instruments, combustion control instruments, medical instruments, all types of safety devices, etc.. Unintended Usage of TOSHIBA products listed in this document shall be made at the customer's own risk.
- The information contained herein is presented only as a guide for the applications of our products. No responsibility is assumed by TOSHIBA CORPORATION for any infringements of intellectual property or other rights of the third parties which may result from its use. No license is granted by implication or otherwise under any intellectual property or other rights of TOSHIBA CORPORATION or others.
- The information contained herein is subject to change without notice.