

**PRELIMINARY DATA SHEET**

# SKY13252-321: PHEMT GaAs IC Diversity Switch DC–6 GHz

## Applications

- WLAN 802.11a, b, g diversity

## Features

- Operating frequency DC–6 GHz
- Positive low voltage control (0/3 V operation)
- Low insertion loss
- High linearity
- Miniature QFN-12 plastic package
- PHEMT process

## Description

The SKY13252-321 is a broadband transfer switch designed to combine T/R and antenna diversity switching functions on a single IC. The device is designed to have a low insertion loss and maintain high linearity at low control voltages. This low cost switch is ideal for Wireless LAN applications and is capable of covering both the 2.4 GHz and 5 GHz bands.

## QFN-12

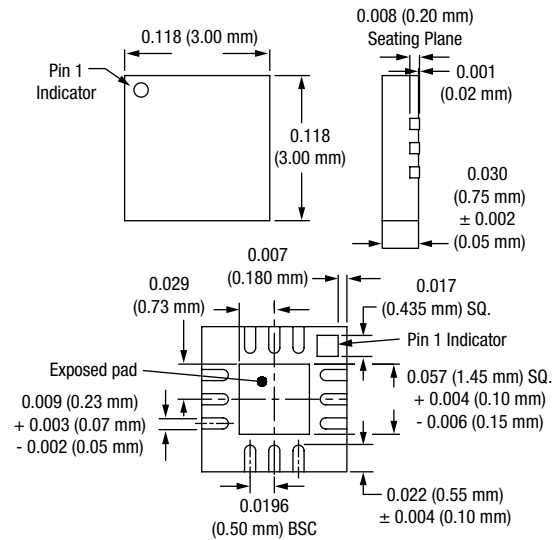

## Electrical Specifications at 25°C (0, +3 V)

Parameter	Condition	Frequency	Min.	Typ.	Max.	Unit
Insertion loss	Ant1, Ant2 to T <sub>X</sub> , R <sub>X</sub>	2.400–2.500 GHz		0.75	0.90	dB
		5.150–5.350 GHz		1.10	1.30	dB
		5.725–5.825 GHz		1.20	1.35	dB
Isolation	Ant1, Ant2 to T <sub>X</sub> , R <sub>X</sub>	2.400–2.500 GHz	27.0	33.0		dB
		5.150–5.350 GHz	23.0	30.0		dB
		5.725–5.825 GHz	21.0	24.0		dB
	Ant1 to Ant2, T <sub>X</sub> to R <sub>X</sub>	2.400–2.500 GHz	20.0	25.0		dB
		5.150–5.350 GHz	17.0	20.0		dB
		5.725–5.825 GHz	17.0	20.0		dB
Return loss	Ant1, Ant2 to T <sub>X</sub> , R <sub>X</sub>	2.400–2.500 GHz		17.0		dB
		5.150–5.350 GHz		13.0		dB
		5.725–5.825 GHz		13.0		dB

## Operating Characteristics at 25°C (0, +3 V)

Parameter	Condition	Frequency	Min.	Typ.	Max.	Unit
P <sub>1</sub> dB	@ 0, +3 V	2–6 GHz		27		dBm
IIP3	5 dBm per tone, 5 MHz spacing, @ 0, +3 V	2–6 GHz		45		dBm
Control voltage	V <sub>LOW</sub> = 0–0.25 V @ 10 μA max. V <sub>HIGH</sub> = 3–5.00 V @ 15 μA max.					

**Typical Performance Data**

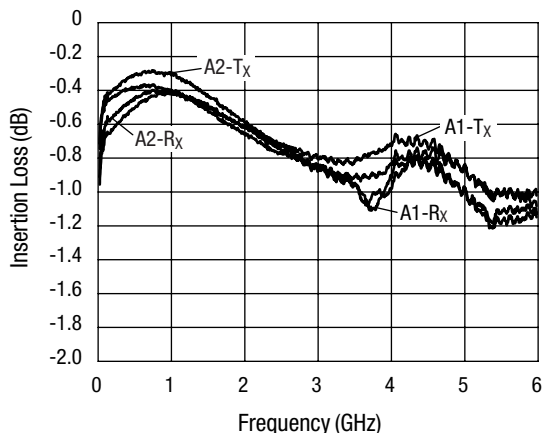

**Insertion Loss vs. Frequency**

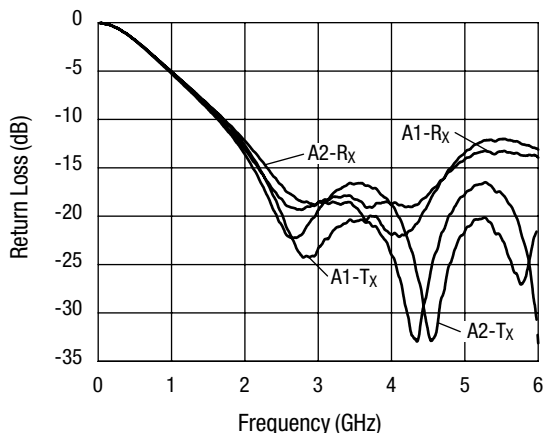

**Return Loss vs. Frequency**

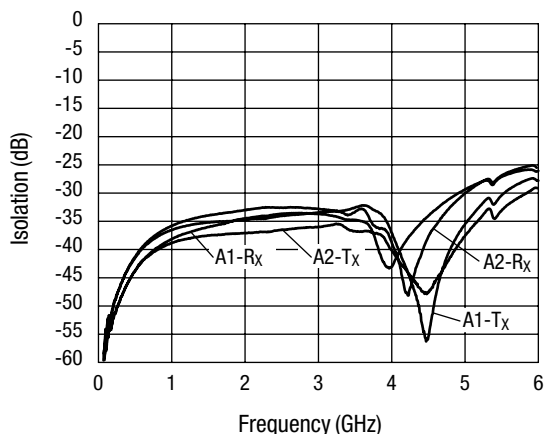

**Isolation vs. Frequency**

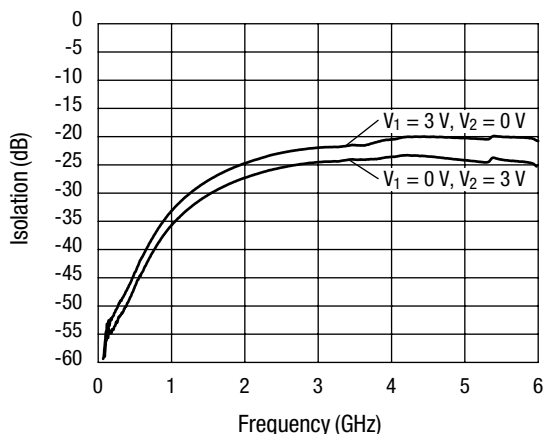

**Isolation Between A1 and A2**

**Truth Table**

Insertion loss path	V <sub>1</sub>	V <sub>2</sub>	State
Ant1-T <sub>x</sub> , Ant2-R <sub>x</sub>	0	1	1
Ant1-R <sub>x</sub> , Ant2-T <sub>x</sub>	1	0	2

**Pin Out (Top View)**

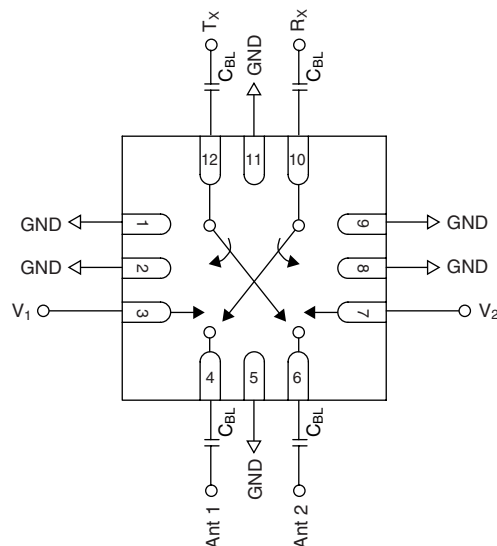

DC blocking capacitors (C<sub>BL</sub>) = 47 pF.