

## Low Voltage, Micro 8, PFET, Buck Controller Ideal for 1A to 5A, Small Footprint, DC-DC Power Converters

- Optimized for Single Supply, 3V-5.5V Applications
- High Efficiency, Greater than 90% Possible
- 20ns/1nF PFET Output Driver
- Fast Transient Response
- Open Drain Fault Output Pin
- Internal Soft Start Circuit
- Accurate 1.5% Reference
- Programmable Output Voltage or Fixed 1.5V Output
- Loss-less Adjustable Current Limit with High side  $R_{DS(ON)}$  Sensing
- Hiccup or Lock-up Fault Modes
- Low 5 $\mu$ A Sleep Mode Quiescent Current
- Low 300 $\mu$ A Protected Mode Quiescent Current
- Ultra Low, 150 $\mu$ A Unprotected Mode Quiescent Current
- High Light Load Efficiency
- Offered in Tiny 8 pin MSOP Package



*Now Available in Lead Free Packaging*

### APPLICATIONS

- Video Cards
- High Power Portable
- Microcontrollers
- I/O & Logic
- Industrial Control
- Distributed Power
- Low Voltage Power

### DESCRIPTION

The **SP6122** is a PWM/PFM minimum on-time controller designed to work from a single 3V-5.5V input supply. It is engineered specifically for size and minimum component count, simplifying the transition from a linear regulator to a switcher solution. However, unlike other "micro" parts, the **SP6122** has an array of value added features such as optional hiccup mode, over current protection, TTL enable, "jitter and frequency stabilization" and a fault flag pull-down pin. Combined with reference and driver specifications usually found on more expensive integrated circuits, the **SP6122** delivers great performance and value in an 8 pin MSOP package.

### TYPICAL APPLICATION CIRCUIT

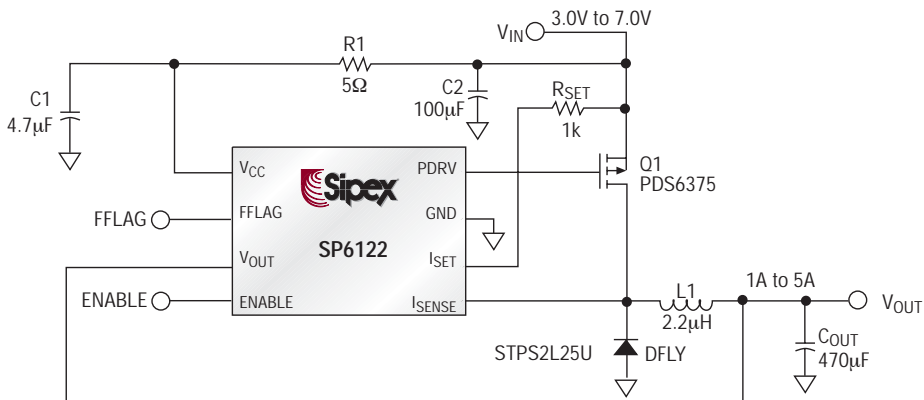

## ABSOLUTE MAXIMUM RATINGS

These are stress ratings only and functional operation of the device at these ratings or any other above those indicated in the operation sections of the specifications below is not implied. Exposure to absolute maximum rating conditions for extended periods of time may affect reliability.

$V_{CC}$ .....	7V
All other pins .....	-0.3V to $V_{CC}+0.3V$
Peak Output Current < 10 $\mu$ s .....	
PDRV .....	2A
Storage Temperature .....	-65°C to 150°C
Power Dissipation .....	
Lead Temperature (Soldering, 10 sec) .....	300°C
ESD Rating .....	2kV HBM

## ELECTRICAL CHARACTERISTICS

Unless otherwise specified: 0°C <  $T_{AMB}$  < 70°C, 3.0V <  $V_{CC}$  < 5.5V,  $C_{PDRV}$  = 1nF,  $V_{ENABLE}$  =  $V_{CC}$ ,  $V_{FFLAG}$  =  $V_{CC}$ ,  $I_{SET}$  =  $I_{SENSE}$  =  $V_{CC}$ , GND = 0.0V

PARAMETER	MIN	TYP	MAX	UNITS	CONDITIONS
<b>QUIESCENT CURRENT</b>					
$V_{CC}$ Supply Current, OVC Enabled	-	300	450	$\mu$ A	No Switching, $I_{SET}$ = $I_{SENSE}$ = $V_{CC}$
$V_{CC}$ Supply Current, OVC Disabled	-	250	360	$\mu$ A	No Switching, $I_{SET}$ = $I_{SENSE}$ = 0
$V_{CC}$ Supply Current, OVC Disabled, Ultra Low IQ	-	150	225	$\mu$ A	No Switching, $I_{SET}$ = 0, $I_{SENSE}$ = $V_{CC}$
$V_{CC}$ Supply Current, Sleep Mode	-	5	15	$\mu$ A	Enable=0
<b>REFERENCE</b>					
Output Voltage, Initial Accuracy	VR*0.985	VR	VR*1.015	V	VR = Factory Set Voltage, see Note
Output Voltage, Over Line, Load and Temperature	VR*0.980	VR	VR*1.020	V	VR = Factory Set Voltage, see Note
Reference Comparator Hysteresis	-	5	-	mV	Internal Hysteresis at Feedback Terminal
$V_{OUT}$ Input Current	-	23	-	$\mu$ A	$V_{OUT}$ = VR; SP6122ACU-1.5 ONLY
<b>OSCILLATOR</b>					
Oscillator Frequency	210	300	390	kHz	
Minimum Pulse Width during Startup (Blanking Time)	150	270	380	ns	
<b>Soft Start</b>					
Soft Start Ramp Time	-	3.5	-	ms	$V_{OUT}$ = VR – 30mV, Measure time from ENABLE = 1V to PDRV Low
Soft Start Voltage when PDRV Switches	-	250	-	mV	Measure $V_{Soft}$ Start when PDRV goes Low. (internal)

## ELECTRICAL CHARACTERISTICS

Unless otherwise specified:  $0^{\circ}\text{C} < T_{\text{AMB}} < 70^{\circ}\text{C}$ ,  $3.0\text{V} < V_{\text{CC}} < 5.5\text{V}$ ,  $C_{\text{PDRV}} = 1\text{nF}$ ,  $V_{\text{ENABLE}} = V_{\text{CC}}$ ,  $V_{\text{FFLAG}} = V_{\text{CC}}$ ,  
 $I_{\text{SET}} = I_{\text{SENSE}} = V_{\text{CC}}$ ,  $\text{GND} = 0\text{V}$

PARAMETER	MIN	TYP	MAX	UNITS	CONDITIONS
<b>RDS OVER CURRENT COMPARATOR</b>					
Over Current Comparator Threshold Voltage	130	150	180	mV	$V(I_{\text{SET}}) - V(I_{\text{SENSE}})$ 25°C only
Threshold Voltage Temperature Coefficient	-	3800	-	ppm/°C	
$I_{\text{SET}}$ Sink Current	15	20	25	μA	Current into $I_{\text{SET}}$ 25°C only
$I_{\text{SET}}$ Current Temperature Coefficient	-	4300	-	ppm/°C	
$I_{\text{SENSE}}$ Input Bias Current	-	-	100	nA	
$I_{\text{SET}}$ , $I_{\text{SENSE}}$ Common Mode Input Range	2.0	-	$V_{\text{CC}}$	V	
Over Current Peak Detection Time Constant	-	10	-	μs	
<b>ENABLE INPUT &amp; FFLAG OUTPUT</b>					
ENABLE Threshold	0.90	1.21	1.45	V	
ENABLE Pin Source Current	0.8	5.0	10.0	μA	
FFLAG Sink Current	3.0	7.5	15.0	mA	$V(\text{FFLAG}) = 1\text{V}$
<b>GATE DRIVER</b>					
PDRV Rise Time		20	75	ns	0.5V to 4.5V
PDRV Fall Time		20	75	ns	4.5V to 0.5V

*NOTE: Available Output Voltages: 1.5V Fixed, 1.25V Adj.*

PIN #	PIN NAME	DESCRIPTION
1	V <sub>CC</sub>	Main Supply Pin: A RC filter as shown in the application circuit is recommended. The decoupling capacitor needs to be close to the pin.
2	FFLAG	Fault Flag Pull-down Pin: Sinks current during a fault condition. Can be hooked up to ENABLE to initiate Hiccup Timing.
3	V <sub>OUT</sub>	Regulated Output Voltage: This voltage is divided internally and compared to a 1.5%, 1.25V reference at the PFM comparator.
4	ENABLE	Enable Input: Floating this pin or pulling above 1.45V enables the part. Pulling this pin to less than 0.9V will disable the part. A minimum 100pF capacitor is required between this pin and Ground to ensure proper startup. If FFLAG is hooked to ENABLE, the capacitor on ENABLE will control hiccup timing.
5	I <sub>SENSE</sub>	Negative Input to the Over Current Amplifier/Comparator: This input is subtracted from the I <sub>SET</sub> input and gained by a factor of 3.3. The output of this amplifier is compared with a 0.5V threshold, yielding a 150mV threshold. This threshold has a 3800 ppm/°C temperature coefficient. If the subtraction exceeds 150mV, charge is pumped into a capacitor until the capacitor hits V <sub>CC</sub> /2. At this time, the over current fault is activated. If I <sub>SET</sub> = 0V and I <sub>SENSE</sub> = V <sub>CC</sub> , the part enters an unprotected, 150µA quiescent current mode.
6	I <sub>SET</sub>	Positive Input to the Over Current Amplifier: 20µA flows into the I <sub>SET</sub> pin if it is pulled through a resistor to V <sub>IN</sub> . This current has a 4300ppm/°C temperature coefficient and can be used via external resistor to raise the overcurrent trip point from 150mV to some higher value. If I <sub>SET</sub> = 0V and I <sub>SENSE</sub> = 0V, the part enters an unprotected, 250µA quiescent current mode.
7	GND	Power and Analog Ground: Hook directly to output ground.
8	PDRV	Drive for PFET High Side Switch: 1nF/20ns Output Driver.

# BLOCK DIAGRAM

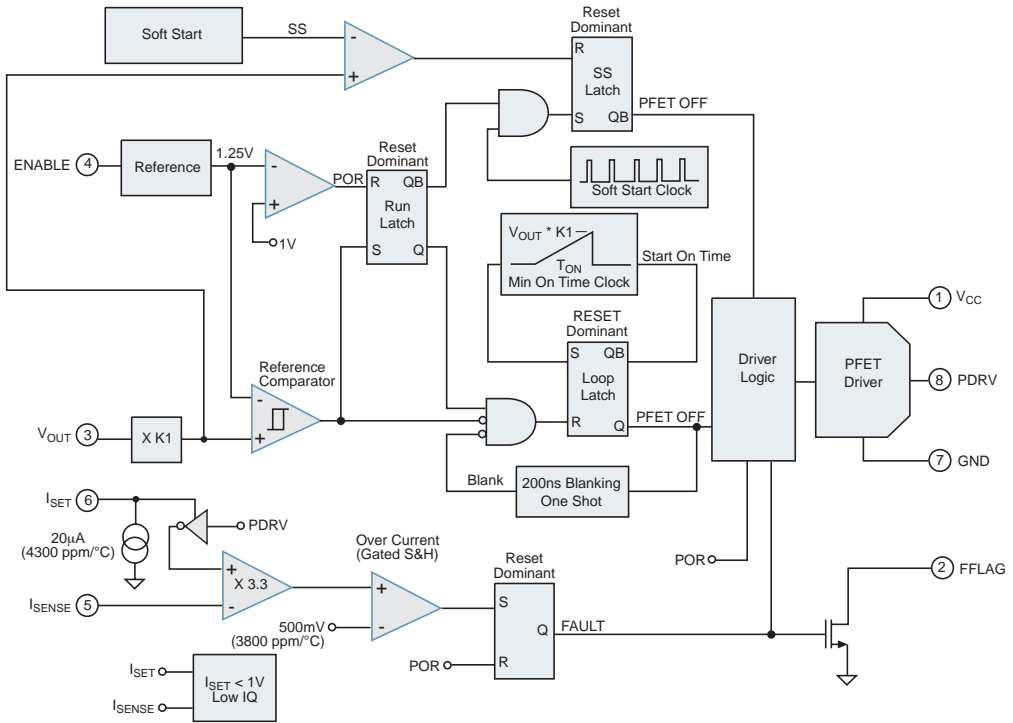

## OPERATION

### General Overview

The SP6122 is a minimum on-time, PFM/PWM controller for low cost DC/DC step down converters. The main control loop consists of a REFERENCE COMPARATOR, an ON-TIME CLOCK, a LOOP LATCH and a BLANKING ONSHOT. The REFERENCE comparator has 10mV of internal hysteresis and a 1.25V internal reference. Both hysteresis and reference voltage are multiplied upward by the internal feedback resistor divider, K1 (K1 = 1 for the adjustable version). This value is set by the factory and determines the output voltage of the converter. This divider is also used in the on-time algorithm for the controller. If the output voltage drops below  $K1 \cdot 1.25V$ , then the DRIVER LOGIC tells the PFET switch to be “on” for a certain minimum time. The on-time is set by the Soft Start CLOCK frequency and is factory programmed to run at 300kHz. When the part is enabled, through  $V_{CC}$  or the ENABLE pin, the DRIVER LOGIC is configured to first look at the fixed frequency Soft Start loop. The output voltage is then controlled by a 0.5V/ms internal ramp. When the output voltage reaches  $K1 \cdot 1.25V$ , the Soft Start loop is switched off and the main loop takes over.

Fault management is controlled either through power-on-reset (POR) or  $R_{DS(ON)}$  sense over current protection. Should an over current condition occur, the SP6122 will completely “lock-up” and turn the PFET switch off. The only way to recover will be to either cycle the ENABLE pin or  $V_{CC}$ . A Fault flag output (FFLAG) has been included to either signal the upstream circuitry or to engage a hiccup mode that will restart the SP6122. Tying FFLAG to ENABLE allows the controller to restart without assistance. Lastly, the SP6122 includes a powerful 4Ω PFET driver stage designed to drive a PFET associated with high speed converter designs in the 1 A – 5 A range.

### Enable

Low quiescent mode or “Sleep Mode” is initiated by pulling the ENABLE pin below 650mV. The ENABLE pin has an internal 4μA pull-up current and does not require any external interface for normal operation. If the ENABLE pin is driven from a voltage source, the voltage must be above 1.45V in order to guarantee proper “awake” operation. Assuming that  $V_{CC}$  is above about 2.9V, the SP6122 transitions from “Sleep Mode” to “Awake Mode” in about 20μs – 30μs and from “Awake Mode” to “Sleep Mode” in a few microseconds. SP6122 quiescent current in sleep mode is 5μA typical. During Sleep Mode, the PFET switch is turned off, the internal SS voltage is held low and the FFLAG pin is high impedance.

### Low Current Operation

If over current fault protection is not needed, the SP6122 offers two options to lower its quiescent current. By grounding both  $I_{SET}$  and  $I_{SENSE}$  pins, the circuitry responsible for over current detection is turned off. This option results in a saving of about 50μA in quiescent current. Option two requires that  $I_{SET}$  is grounded and  $I_{SENSE}$  is greater than 1.3V. This option put the SP6122 in a low performance mode that cuts the operating frequency roughly in half and slows down critical comparators in the main loop. Option two can result in additional saving of 100μA bringing the total quiescent current to only 150μA (typ).

### Power On Reset (POR)

The POR command is given every time the bandgap reference is started. The internal 1.25 V reference is compared against a 1V NFET threshold. When the reference is below the threshold, FAULT and RUN latches are reset, the internal SS voltage is discharged and the PFET switch is “off”. The SP6122 is allowed to begin a soft start cycle when the

## Power On Reset (POR): continued

internal 1.25V is greater than the 1 V threshold. Note this is a “loose” threshold and should not be used to guarantee under voltage lock out with respect to  $V_{CC}$ . Care should be taken to ensure that  $V_{CC}$  does not “get stuck” on the way to its regulated value.

## Soft Start

Soft start is required on step-down controllers to prevent excess inrush current through the power train during start-up. On the SP6122, this is managed through turning the PFET switch on with a fixed frequency clock and then turning the switch off when divided down version of the output voltage exceeds the internal SS voltage ramp. The internal SS voltage ramp rises with a 0.5 V/ms slew rate and the internal feedback voltage follows this rate of change. The presence of the output capacitor creates extra current draw during startup. Since  $dV_{OUT}/dt$  creates an average sustained current in the output capacitor, this current must be considered while calculating peak

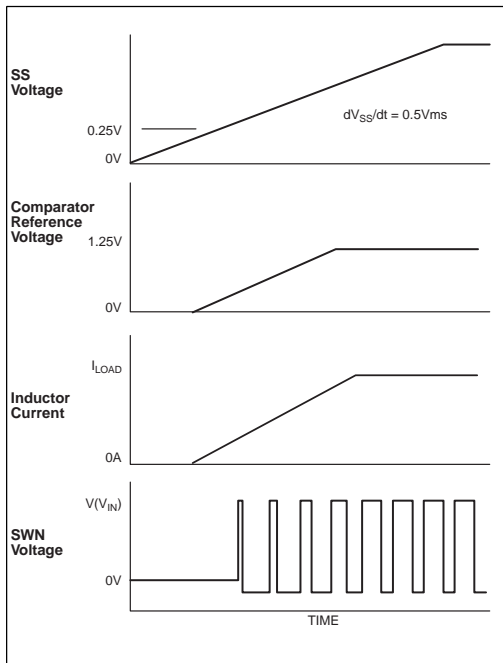

inrush current and over current thresholds. An expression to determine the excess inrush current due to the  $dV_{OUT}/dt$  of the output capacitor is:

$$I_{C_{OUT}} = C_{OUT} * 0.5 \text{ V/ms} * \frac{V_{OUT}}{V_R}$$

where  $V_R$  is the internal reference voltage.

## Lock Up & Hiccup Modes

As previously stated, if the SP6122 detects an over current condition and initiates a fault, the power supply remains “locked up”. That is, the FFLAG pin immediately pulls low (if loaded) and the PFET switch turns off. This condition is permanent unless the either the  $V_{CC}$  or ENABLE is cycled. However if FFLAG is tied to ENABLE, the SP6122 will restart without assistance (Hiccup Mode). Furthermore, the restart time can be controlled by the addition of a small capacitor on the ENABLE pin to ground. The restart time is equal to the amount of time it takes for the  $5\mu A$  ENABLE pin current to charge the external capacitor to an NFET threshold (roughly 1V). The waveforms that describe the Hiccup Mode operation are shown below.

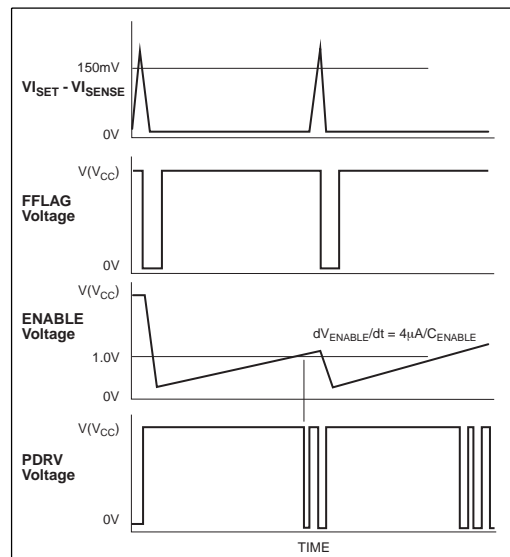

## Over Current Protection

Over current protection on the SP6122 is implemented through detection of an excess voltage condition across the PFET switch during conduction. This is typically referred to as high side  $R_{DS(ON)}$  detection. The over current comparator charges a sampling capacitor each time  $V(I_{SET}) - V(I_{SENSE})$  exceeds 150mV (typ) and the PDRV voltage is low. The discharge current/charge current ratio on the sampling capacitor is about 2%. Therefore, provided that the over current condition persists, the capacitor voltage will be pumped up during each time PDRV switches low and this voltage will trigger an over current condition upon reaching a CMOS inverter threshold. There are many advantages to this approach. First, the filtering action of the gated S/H scheme protects against false triggering during a transient load condition or supply line noise. In addition, the total amount of time to trigger the fault depends on the on-time of the PFET switch. Ten, 1 $\mu$ s pulses are equivalent to twenty, 500ns pulses or one, 1 $\mu$ s pulse, however, depending on the period, each scenario takes a different amount of total time to trigger a fault. Therefore, the fault becomes an indicator of average power in the PFET switch. Also, because the CMOS trip threshold is dependent on  $V_{CC}$ , the over current scheme is protected against false triggering due to changes in line voltage.

Although the 150mV threshold is fixed, the overall  $R_{DS(ON)}$  detection voltage can be increased by placing a resistor from  $I_{SET}$  to  $V_{CC}$ . A 20 $\mu$ A sink current programs the additional voltage.

The 150 mV threshold and 20 $\mu$ A  $I_{SET}$  current have 3800 ppm/ $^{\circ}$ C and 4300 ppm/ $^{\circ}$ C temperature coefficients, respectively. These TC's are designed into the SP6122 in an effort to match the thermal character-

istics of the PFET switch. It assumed that the SP6122 will be used in compact designs where there is a high amount of thermal coupling between the PFET and the controller.

## Light Load Operation

One of the advantages of the SP6122 minimum on-time control scheme is the loop's ability to seamlessly and efficiently transition from heavy loads to light loads. In most other control schemes, the controller is notified about a light load condition and then must abruptly change control schemes in order to maintain efficiency. The SP6122 simply reduces the frequency when the average load current is less than the average inductor ripple current. As a result, switching loss decreases as the load current decreases and overall efficiency is maintained.

## Output Driver

The driver stage consists of a high side, 4 ohm PFET driver. The following waveforms illustrate basic behavior of the driver.

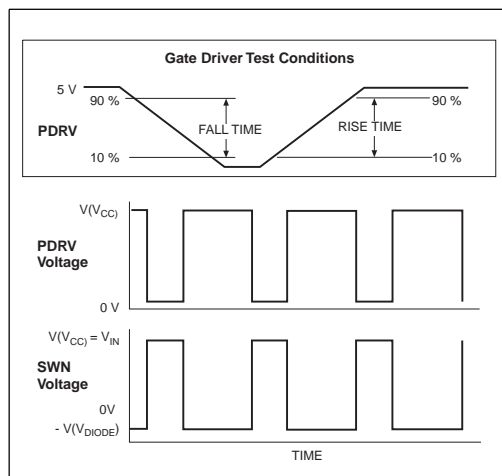





## Data For Evaluation Board: *continued*

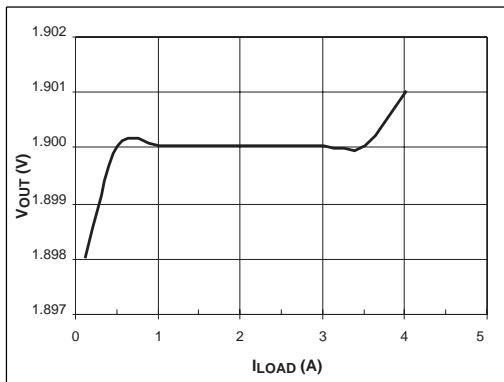

Figure 3. SP6122 Load Regulation with Input Voltage = 3.3V.

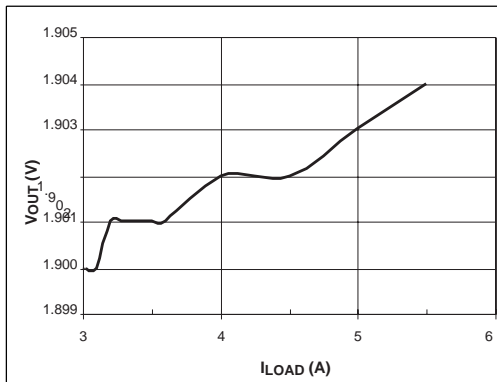

Figure 4. SP6122 Line Regulation with  $I_{LOAD} = 2A$ .

## Guidelines for Component Selection

### GENERAL

The SP6122 is a minimum on-time PFM controller. This means there is no error amp controlling the loop. Although an internal algorithm adjusts the on-time approximate the performance of a fixed frequency controller, the loop control is generated by looking at OUTPUT RIPPLE. The peak to peak value of this output ripple must be no less than 2% of the DC output voltage in order to maintain reasonable fixed frequency operation. In addition, as with all PFM controllers, board layout is critical and careful attention must be paid to minimize paths that can generate noise. Fortunately, the SP6122 is designed for simplicity and minimal external components, making it easy to design small, quiet power converters up to 12W.

### INDUCTOR SELECTION

In a SP6122 application, the main factors for choosing an inductor are likely to be cost, size, saturation current and efficiency. If you use low inductor values, you get the smallest size, but you may cause larger ripple currents and poor efficiency and require more output capacitance to smooth the output ripple. Increasing the inductor value will decrease the output voltage ripple but degrade the transient response. For a good compromise between size, losses and

cost, set the inductor ripple current between 20% to 40% of the maximum output current.

The inductor operating point and switching frequency determine the inductor value as seen in the following expression:

$$L = \frac{(V_{OUT} + V_{DIODE}) * (V_{IN} - V_{OUT})}{((V_{IN} + V_{DIODE}) * (F_S K_R I_{OUT(max)}))}$$

Where  $F_S$  = switching frequency (see Soft Start Frequency Specification)

$K_R$  = ratio of the ac inductor ripple current to the maximum output current

$V_{DIODE}$  = forward Schottky diode voltage

For an application with 1.9V out, 4A maximum  $I_{OUT}$ , 3.3V input supply, 400 mV typical forward diode voltage, 300kHz frequency and a 30% inductor ripple current, a 2.2 $\mu$ H inductor was selected (see Table 1 SP6122 Component Selection).

The peak to peak inductor ripple current is:

$$I_{PP} = \frac{(V_{OUT} + V_{DIODE}) * (V_{IN} - V_{OUT})}{((V_{IN} + V_{DIODE}) * (F_S L))}$$

For that same 2.2 $\mu$ H inductor application, the  $I_{PP} = 1.32A$ .

The inductor must be selected to not saturate the core at the peak inductor current:

$$I_{PEAK} = I_{OUT(max)} + I_{PP}/2$$

## Guidelines for Component Selection: *continued*

Again, for that same 2.2μH application,  $I_{PEAK} = 4.6A$ . Therefore, a 2.2μH inductor with at least a 5A rating would be desired.

The type of core material to use must also be determined. For low cost, powdered iron cores can be used, and they have a gradual saturation characteristic, but they can cause ac core loss when the inductor value is low and ripple current is high. Ferrite cores, on the other hand, have an abrupt saturation characteristic and the inductor value drops sharply when the peak design current is exceeded. But, ferrites are preferred for

high switching frequencies because they have low core losses as long as the saturation current is avoided.

Table 1 lists examples of both shielded and unshielded ferrite core inductors for applications appropriate for SP6122 applications from 2A to 5A output current. The inductors listed are both shielded and unshielded, the customer can decide what is needed for their application. For the SP6122 Evaluation Board, the unshielded ferrite inductor 2.2μH Coilcraft DO3316P-222 was selected for its cost/performance features.

<b>INDUCTORS - SURFACE MOUNT</b> <i>Note: Components highlighted in <b>bold</b> are those used on the SP6122 Evaluation Board.</i>						
Inductance (μH)	Manufacturer/ Part No.	INDUCTOR SPECIFICATION				Manufacturer Website
		Series R (Ω)	Isat (A)	Size LxWxH (mm)	Inductor Type	
1.5	Coilcraft DO3316P-152	0.010	8.0	12.9x9.4x5.0	Unshielded Ferrite Core	www.coilcraft.com
<b>2.2</b>	<b>Coilcraft DO3316P-222</b>	<b>0.012</b>	<b>7.0</b>	<b>12.9x9.4x5.0</b>	<b>Unshielded Ferrite Core</b>	www.coilcraft.com
3.3	Coilcraft DO3316P-332	0.015	6.4	12.9x9.4x5.0	Unshielded Ferrite Core	www.coilcraft.com
1.5	Sumida CDRH104R-1R5	0.006	10.0	10x10x3.8	Shielded Ferrite Core	www.sumida.com
2.5	Sumida CDRH104R-2R5	0.008	7.5	10x10x3.8	Shielded Ferrite Core	www.sumida.com
3.8	Sumida CDRH104R-3R8	0.010	6.0	10x10x3.8	Shielded Ferrite Core	www.sumida.com
1.5	Murata LQN6C1R5M04	0.019	3.7	5.0x5.7x4.7	Unshielded Ferrite Core	www.murata.com
2.2	Murata LQN6C2R2M04	0.024	3.2	5.0x5.7x4.7	Unshielded Ferrite Core	www.murata.com
3.3	Murata LQN6C3R3M04	0.029	2.7	5.0x5.7x4.7	Unshielded Ferrite Core	www.murata.com

<b>CAPACITORS - SURFACE MOUNT &amp; THROUGH HOLE</b> <i>Note: Components highlighted in <b>bold</b> are those used on the SP6122 Evaluation Board.</i>							
Capacitance (μF)	Manufacturer/ Part No.	CAPACITOR SPECIFICATION				Manufacturer Website	
		ESR Ω (max)	Ripple Current (A) @ 25°C	Size LxWxH (mm)	Voltage (V)		Capacitor Type
<b>470</b>	<b>SANYO 6TPB470M</b>	<b>0.035</b>	<b>3.0</b>	<b>7343H</b>	<b>10.0</b>	<b>SMT Tant.</b>	www.sanyovideo.com
<b>47</b>	<b>TDK C4532X5R0J476M</b>	<b>0.005</b>	<b>4.0</b>	<b>1812</b>	<b>6.3</b>	<b>SMT X5R Cer.</b>	www.tdk.com
<b>4.7</b>	<b>TDK C3216X5R1C475M</b>	<b>0.020</b>	<b>4.0</b>	<b>1206</b>	<b>10.0</b>	<b>SMT X5R Cer.</b>	www.tdk.com
100	SANYO 16SA100M	0.030	2.7	8Dx10L	16.0	Thru-hole OS-CON	www.sanyovideo.com

<b>PMOS SWITCH - SURFACE MOUNT</b> <i>Note: Components highlighted in <b>bold</b> are those used on the SP6122 Evaluation Board.</i>						
Manufacturer/Part No.	PMOS SPECIFICATION					Manufacturer Website
	R <sub>DS(ON)</sub> Ω @ 3.3V	Gate Charge nC @ 3.3V	C <sub>rss</sub> (pF)	I <sub>d</sub> (max) (A)	Package Type	
<b>Fairchild PDS6375</b>	<b>0.022</b>	<b>15</b>	<b>300</b>	<b>8</b>	<b>SO-8</b>	www.fairchildsemi.com
Siliconix SI4463DY	0.015	34	800	10	SO-8	www.siliconix.com
Intersil ITF86172SK8T	0.023	17	400	8	SO-8	www.intersil.com

<b>SCHOTTKY DIODE - SURFACE MOUNT</b> <i>Note: Components highlighted in <b>bold</b> are those used on the SP6122 Evaluation Board.</i>						
Manufacturer/Part No.	DIODE SPECIFICATION					Manufacturer Website
	V <sub>F</sub> @ I <sub>F</sub> (V)	I <sub>F(AV)</sub> (A)	Size LxWxH (mm)	Reverse V (V)	Package Type	
<b>STMicro STPS2L25U</b>	<b>0.50</b>	<b>4.0</b>	<b>5.5x3.9x2.5</b>	<b>25</b>	<b>SMB</b>	www.st.com
On-Semi MBRD835L	0.50	8.0	9.4x6.7x2.3	35	DPAK	www.onsemi.com

**Table 1: SP6122 Component Selection**

## Guidelines for Component Selection: *continued*

The copper loss in the inductor can be calculated from the equation:

$$P_{L(\text{Cu})} = I_{L(\text{RMS})}^2 R_{\text{WINDING}} \cong I_{\text{OUT}(\text{max})}^2 R_{\text{WINDING}}$$

For the 2.2 $\mu$ H example with 0.012 $\Omega$  ESR in the winding, 4A load and 1.9V output, the copper loss in the inductor is 190mW.

### OUTPUT CAPACITOR SELECTION

The output capacitor is typically selected based on its ability to maintain the output within specified tolerance limits during load transients. During an output load transient, the output capacitor must supply all the additional current demanded by the load until the SP6122 adjusts the inductor current to the new value. Therefore the capacitance must be large enough so that the output voltage is held up while the inductor current ramps up or down to the value corresponding to the new load current. For power converters delivering greater than 1A at less than 1MHz switching frequency, the output capacitor is typically greater than 100 $\mu$ F. Typically, tantalum and OSCON capacitors are used to get high output capacitance in a small space. These capacitors have a high Equivalent Series Resistance (ESR) when compared to ceramic capacitors and this ESR is both a curse and a blessing. Unfortunately, the ESR (Equivalent Series Resistance) in the output capacitor causes a step in the output voltage equal to the ESR value multiplied by the change in load current. As a result, in a power supply using a tantalum, aluminum electrolytics or OSCON output capacitor, the value of output capacitance (or number of output capacitors) is typically chosen to minimize the output variation due to the load step imposed on this ESR. However, the SP6122 takes advantage of the natural presence of this ESR to control the loop. Because the inductor ripple current also flows through this ESR, and output ripple voltage is created and the waveform resembles a miniature current-mode timing

waveform. For a 1.9V output voltage, the required ripple is a reasonable 38 mV. The designer must choose all other trade-offs wisely to maintain this ripple

$$0.02 * V_{\text{OUT}} < I_{\text{PP}} * R_{\text{ESR}}$$

and

$$\Delta I_{\text{LOAD}} * R_{\text{ESR}} < \Delta V_{\text{TOL}}$$

where:

$V_{\text{OUT}}$  = DC output voltage

$R_{\text{ESR}}$  = ESR of the output capacitor

$\Delta I_{\text{LOAD}}$  = change in current due to load step

$\Delta V_{\text{TOL}}$  = tolerable deviation due to load transient

$I_{\text{PP}}$  = peak to peak inductor ripple current

Output ripple is due primarily to the output ripple current and the output capacitor ESR value as seen in the following equation:

$$\Delta V_{\text{OUT}} \cong I_{\text{PP}} R_{\text{ESR}}$$

For our SP6122 evaluation board example with ESR = 35m $\Omega$  and  $I_{\text{PP}}$  = 1.32A,  $\Delta V_{\text{OUT}}$  = 46mV. Note that a 4A step creates a 140mV deviation. If this is unacceptable, ESR and  $I_{\text{PP}}$  must be reconsidered in order to improve step response and maintain output ripple.

Recommended capacitors that can be used effectively in SP6122 applications are: low-ESR aluminum electrolytic capacitors, OSCON capacitors that provide a very high performance/size ratio for electrolytic capacitors and low-ESR tantalum capacitors. AVX TPS series and Kemet T510 surface mount capacitors are popular tantalum capacitors that work well in SP6122 applications. POSCAP from Sanyo is a solid electrolytic chip capacitor that has low ESR and high capacitance. For the same ESR value, POSCAP has lower profile compared with a tantalum capacitor.

## Guidelines for Component Selection: *continued*

### INPUT CAPACITOR SELECTION

The input capacitor should be selected for ripple current rating, capacitance and voltage rating. The input capacitor must meet the ripple current requirement imposed by the switching current. In continuous conduction mode, the source current of the high-side MOSFET is approximately a square wave of duty cycle  $V_{OUT}/V_{IN}$ . Most of this current is supplied by the input bypass capacitors. The RMS value of input capacitor current is determined at the maximum output current and under the assumption that the peak to peak inductor ripple current is low, it is given by:

$$I_{CIN(RMS)} = I_{OUT(MAX)}\sqrt{D(1-D)}$$

The worse case occurs when the duty cycle  $D$  is 50% and gives an RMS current value equal to  $I_{OUT}/2$ . Select input capacitors with adequate ripple current rating to ensure reliable operation. The power dissipated in the input capacitor is:

$$P_{CIN} = I_{CIN}^2 (RMS) R_{ESR(CIN)}$$

This can become a significant part of power losses in a converter and hurt the overall energy transfer efficiency. The input voltage ripple primarily depends on

the input capacitor ESR and capacitance. Ignoring the inductor ripple current, the input voltage ripple can be determined by:

$$\Delta V_{IN} = I_{OUT(MAX)} R_{ESR(CIN)} + I_{OUT(MAX)} V_{OUT} (V_{IN} - V_{OUT}) / (F_S C_{IN} V_{IN}^2)$$

The capacitor type suitable for the output capacitors can also be used for the input capacitors. However, exercise extra caution when tantalum capacitors are considered. Tantalum capacitors are known for catastrophic failure when exposed to surge current, and input capacitors are prone to such surge current when power supplies are connected 'live' to low impedance power sources. Certain tantalum capacitors, such as AVX TPS series, are surge tested. For generic tantalum capacitors, use 2:1 volt-

age derating to protect the input capacitors from surge fall-out.

For accurate control it is important to keep ripple voltages on  $V_{in}$  to a minimum.  $V_{in}$  powers the SP6122 and its internal reference used to maintain output regulation, so proper input bypassing is critical to reduce reference noise. With a reference comparator internal hysteresis of 5mV, and a 1.25V reference voltage, noise on the  $V_{CC}$  of the  $I_{CC}$  should be kept to about 20mV or less to reduce reference noise effect on output regulation.

The use of very low ESR capacitors is recommended for  $V_{in}$  bypassing, through the use of parallel combinations of tantalum capacitors or even better using some of the new large valued multi-layer ceramic capacitors. ESR values as low as  $0.005\Omega$  can be obtained with a  $47\mu F$  ceramic (see table 1 capacitor selection) and these ceramic capacitors will reduce the power loss in the input capacitance greatly by their reduced ESR values.

For the SP6122 example using the  $47\mu F$  ceramic input capacitor, the  $P_{CIN} = 20mW$ , which is very efficient, and the input ripple voltage at the  $V_{IN}$  post (not the  $V_{CC}$  pin of the IC) is about 90mV.

### MOSFET SELECTION

A SP6122 design uses a PMOS switch on the high side, without the need for a high side charge pump, simplifying the application circuit. The losses associated with the PMOS can be divided into conduction and switching losses. Conduction losses are related to the on resistance of the PMOS, and increase with the load current. Switching losses occur on each on/off transition when the PMOS experiences both high current and voltage. The switching losses are difficult to quantify due to all the variables affecting turnon/turnoff time. However, the following equation provides an approximation on the switching losses associated with the PMOS driven by SP6122.

## Guidelines for Component Selection: *continued*

$$P_{SH(MAX)} \approx 1/2 I_{OUT(MAX)} V_{IN(MAX)} (t_{RISE} + t_{FALL}) F_S$$

where  $t_{RISE}$  (SP6122) for 8A PMOS is typically 20ns and  $t_{FALL}$  (SP6122) for 8A PMOS is typically 40ns.

Switching losses need to be taken into account for high switching frequency, since they are directly proportional to switching frequency. The conduction losses associated with the PMOS is determined by:

$$P_{CH(MAX)} = I_{OUT(MAX)}^2 R_{DS(ON)} D$$

Where  $R_{DS(ON)}$  = drain to source on resistance.

The total power losses of the PMOS are the sum of switching and conduction losses. For input voltages of 3.3V and 5V, conduction losses often dominate switching losses. Therefore, lowering the  $R_{DS(ON)}$  of the PMOS always improves efficiency even though it gives rise to higher switching losses due to increased  $C_{RSS}$ .

For the SP6122 design example, the Fairchild PMOS PDS6375 was selected for its low  $R_{DS(ON)}$  and good switching characteristics including low gate charge at the 3.3V input. Using table 1 values for  $R_{DS(ON)}$  and  $t_{RISE}$  and  $t_{FALL}$  for the SP6122, we calculate;

$$P_{SH(MAX)} = 119mW \text{ and } P_{CH(MAX)} = 203mW.$$

$R_{DS(ON)}$  varies greatly with the gate driver voltage. The MOSFET vendors often specify  $R_{DS(ON)}$  on multiple gate to source voltages ( $V_{GS}$ ), as well as provide typical curve of  $R_{DS(ON)}$  versus  $V_{GS}$ . For 5V input, use the  $R_{DS(ON)}$  specified at 4.5V  $V_{GS}$ . At the time of this publication, vendors, such as Fairchild, Siliconix and International Rectifier, have started to specify  $R_{DS(ON)}$  at  $V_{GS}$  less than 3V. This has provided necessary data for designs in which these MOSFETs are driven with 3.3V and made it possible to use SP6122 in 3.3V only applications.

Thermal calculation must be conducted to ensure the MOSFET can handle the maximum load current. The junction temperature of the MOSFET, determined as follows, must stay below the maximum rating.

$$T_{J(MAX)} = T_{A(MAX)} + P_{MOSFET(MAX)} R_{\theta JA}$$

where

$T_{A(MAX)}$  = maximum ambient temperature

$P_{MOSFET(MAX)}$  = maximum power dissipation of the MOSFET, including both switching and conduction losses

$R_{\theta JA}$  = junction to ambient thermal resistance.

$R_{\theta JA}$  of the device depends greatly on the board layout, as well as device package. Significant thermal improvement can be achieved in the maximum power dissipation through the proper design of copper mounting pads on the circuit board. For example, in a SO-8 package, placing two 0.04 square inches copper pad directly under the package, without occupying additional board space, can increase the maximum power from approximately 1 to 1.2W.

For the PMOS PDS6375, assuming  $T_{A(MAX)} = 20^\circ\text{C}$ ,  $P_{MOSFET(MAX)} = P_{SH(MAX)} + P_{CH(MAX)} = 321mW$ , and assuming per PDS6375 data sheet,  $R_{\theta JA} = 50^\circ\text{C/W}$  if using 0.5 in<sup>2</sup> pad of 2oz Cu,

$$T_{J(MAX)} = 36^\circ\text{C}$$

which is only a 16°C rise from ambient.

### SCHOTTKY DIODE SELECTION

The schottky diode is selected for low forward voltage, current capability and fast switching speed. The average power dissipation of the schottky diode is determined by

$$P_{DIODE} = V_F I_{OUT} (1 - D)$$

Where  $V_F$  is the forward voltage of the Schottky diode at  $I_{OUT}$ .

## Guidelines for Component Selection: *continued*

For the SP6122 example, the schottky STPS2L25U has  $V_F = 0.5V$  for  $I_{OUT}$  of 4A, the power loss in the schottky  $P_{DIODE} = 848mW$ .

Note that this power dissipation is 2.5 times greater than the MOSFET. If we assume the same thermal conductivity as the MOSFET (according to the data sheets, this is close) we should get a 40°C rise due to the Schottky diode alone. It is apparent that due to the proximity of all the components involved that the board temperature is higher than ambient and this temperature rise must be considered when attempting to protect the power converter.

## Features and Protection

### PROGRAMMING THE SP6122 OUTPUT VOLTAGE

For Applications requiring output other than 1.5V, the 1.25V adjustable version is recommended. The output voltage can be programmed through a simple voltage divider shown in Figure 5. The set point for the output voltage can be determined by

$$V_{OUT} = \frac{1.25 (R1 + R2)}{R2}$$

Select R1 and R2 in the range from 1k to 100k.

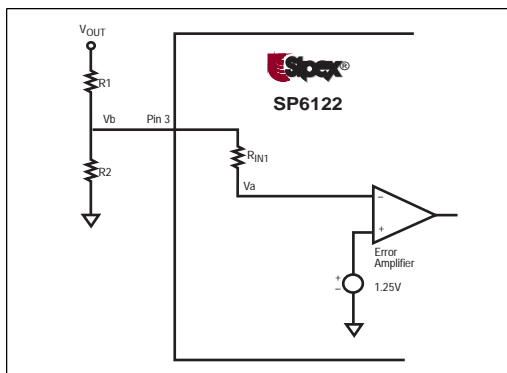

Figure 5: Schematic: Output Voltage Divider Resistors

The 1.5V version of SP6122 has built in voltage divider that presets the output voltage. Simply connect the  $V_{OUT}$  pin to the power supply output for 1.5V regulation. Due to the internal voltage divider, the version of SP6122 sinks 23 $\mu A$  current at the  $V_{OUT}$  pin. Consider this error term if a resistor voltage divider is used.

### SOFT START

The SP6122 has a built-in soft start feature that automatically limits the inrush currents to reasonable levels for most power supplies. For our 1.9V example, the inrush current on start up is:

$$I_{INRUSH} = 470\mu F * 0.5V/ms * 1.9V/1.25V \\ = 357mA$$

This extra current must be factored in when calculating over current margins.

### LOCK-UP AND HICCUP MODES

Basically, when the SP6122 sees an over current fault, the part can react in two ways. If the FFLAG is not tied to ENABLE, the part will put the driver into a low impedance state to the high rail during a fault. The ENABLE pin must be manually cycled to remove the fault. This mode is useful when power supply sequencing and system fault management is complex. If the FFLAG pin is tied to ENABLE, then a 'hiccup' time can be designed by adding a capacitor from ENABLE to ground. The 4 $\mu A$  ENABLE pin charge current acts as a timer. The driver will be put into a low impedance state to the high rail for a certain amount of time.

$$T_{OFF} = C_{ENABLE} * 1.21V/5\mu A$$

For  $C_{ENABLE} = 4.7nF$ , this time equals 1.3ms. This represents a 'cool off' time required for the power supply to cycle and see if the fault has been removed. This mode is useful for short term faults or in single supply systems.

## Features and Protection: *continued*

### $R_{DS(ON)}$ OVER CURRENT PROTECTION

Fault conditions are detected via an over voltage condition across the PMOS switch during conduction. This is commonly known as  $R_{DS(ON)}$  sensing.  $R_{DS(ON)}$  sensing is inaccurate but efficient and is used where an indicator of over current behavior is required for protection. Two advanced features are incorporated in the SP6122  $R_{DS(ON)}$  sensing scheme. The sensing environment is very noisy. Typical schemes require some external filtering in order to avoid spurious faults due to noise or load transients, often compromising the protection and performance at low duty ratios. The SP6122 incorporates a 10 $\mu$ s internal sample and hold filter after the main sense comparator. In this fashion, small pulse widths can be detected while maintaining adequate filtering against false glitches. In addition, temperature compensation is added such that the over current detection threshold at any temperature can be calculated with reasonable accuracy at room temperature. For our evaluation board example:

$$I_{TRIP} = (150mV + I_{SET}R_{SET})/R_{DS(ON)} = \\ (150mV + 20\mu A * 1k\Omega) / 25m\Omega = 6.8A$$

This is the about the same trip threshold at room, hot or cold because a temperature coefficient has been added to both the 150mV and the 20 $\mu$ A set currents. This temperature coefficient tracks the 25m $\Omega$   $R_{DS(ON)}$  of the external FET. Due to the small size of these power supplies, thermal coupling exists between the PFET and the SP6122, making this thermal compensation reasonable, but not perfect. Notice there is about a 50% pad between the maximum usable current (5A) and the over current trip threshold (7A) in order to accommodate PFET and overall system variation.

## Layout Guidelines

PCB layout plays a critical role in proper function of the converters and EMI control. In switch mode power supplies, loops carrying high di/dt give rise to EMI and ground bounce. The goal of layout optimization is to identify these loops and minimize them. It is also crucial on how to connect the controller ground such that its operation is not affected by noise. The following guidelines should be followed to ensure proper operation.

1. A ground plane is recommended for minimizing noises, copper losses and maximizing heat dissipation.
2. Connect the ground of the feedback divider to the GND pin of the IC. Then connect this pin as close as possible to the ground of the output capacitor.
3. The Vcc bypass capacitor should be right next to the Vcc and GND pins.
4. The traces connecting to the feedback resistors and current sense components should be short and far away from the switch node and switching components.
5. Minimize the trace length/maximize the trace width between the PDRV pin and the gate of the PMOS.
6. Minimize the loop composed of input capacitors, PMOS and Schottky diode, as this loop carries high di/dt current. Also increase the trace width to reduce copper losses.
7. Maximize the trace width of the loop connecting the inductor, output capacitors, and Schottky diode.
8. For an layout example of an SP6122 power supply (3.3Vin and 1.9Vout at 4A) see the SP6122 Evaluation Board Manual.



## SP6122 Design Calculator Example: Evaluation Board with 3.3V<sub>IN</sub>, 1.9V<sub>OUT</sub>

Table 2, SP6122 Design Calculator, illustrates the calculations and formulas contained in the Sipex Non-Synchronous Buck Cad Calculator spreadsheet, (available in the applications section of the Sipex website at [www.sipex.com](http://www.sipex.com)). The example shown is the same SP6122 Evaluation Board used previously with V<sub>IN</sub> = 3.3V, V<sub>OUT</sub> = 1.9V at

4A. As you can see, the SP6122 efficiency at 4A output is calculated to be 84.3%. Compare this with the Typical Performance Characteristics curve of 84.5%, which is very close considering the tolerances of various components, and you see how useful this easy design calculator is to evaluate your SP6122 designs.

### SP6122 Non-Synchronous Buck Design Calculator

STEADY STATE CALCULATION				
Enter Values		Calculation Results		Formula
V <sub>IN</sub> = Input Voltage (V)	3.3	D = Duty Cycle	0.58	= V <sub>OUT</sub> /V <sub>IN</sub>
V <sub>OUT</sub> = Output Voltage (V)	1.9	I <sub>ripple</sub> = Ripple Current (A)	1.22	= (V <sub>IN</sub> -V <sub>OUT</sub> )*V <sub>OUT</sub> /(Fs*1000*L*0.000001*V <sub>IN</sub> )
Fs = Switching Frequency (kHz)	300	I <sub>peak</sub> = Peak Inductor Current (A)	4.61	= I <sub>OUT</sub> +I <sub>ripple</sub> /2
I <sub>OUT</sub> = Load Current (A)	4	Output Ripple (mV)	42.75	= I <sub>ripple</sub> *ESR <sub>out</sub>
L = Inductance (μH)	2.2	I <sub>in</sub> = Max Input Current (A)	2.56	= I <sub>OUT</sub> *D/0.9
ESR <sub>in</sub> = Input Capacitor ESR (mΩ)	5	Max Input Ripple (mV)	96.99	= I <sub>OUT</sub> *ESR <sub>in</sub> +I <sub>in</sub> *(1-D)/(Fs*C <sub>IN</sub> *0.000001)
C <sub>IN</sub> = Input Capacitance (μF)	47	I <sub>in_rms</sub> = Input Cap RMS Current (A)	1.98	= I <sub>OUT</sub> *SQRT(D*(1-D))
ESR <sub>OUT</sub> = Output Capacitor ESR (Ω)	35			
EFFICIENCY CALCULATION				
Enter Values		Calculation Results		Formula
RGH = GH Impedance (Ω)	4	P <sub>ic</sub> = IC Power (switching) (mW)	31.35	= I <sub>cc</sub> *V <sub>IN</sub> +Chs*V <sub>IN</sub> *Fs*0.001
<b>PMOS</b>				
T <sub>RISE</sub> = SP6122 typ. PMOS rise time (ns)	20	P <sub>sch</sub> = Schottky Conducting Loss (mw)	848.48	= Vf*I <sub>OUT</sub> *(1-D)*1000
T <sub>FALL</sub> = SP6122 typ. PMOS rise time (ns)	40			
Chs = PMOS Gate Charge @ V <sub>IN</sub> (nC)	15	P <sub>ch</sub> = PMOS Conducting Loss (mW)	202.67	= I <sub>OUT</sub> *I <sub>OUT</sub> *D*Rhs
Rhs = R <sub>DS(ON)</sub> @ V <sub>IN</sub> (mΩ)	22	P <sub>sh</sub> = PMOS Switching Loss (mW)	118.80	= 1/2*I <sub>OUT</sub> *V <sub>IN</sub> *(T <sub>RISE</sub> +T <sub>FALL</sub> )*Fs*0.001
		P <sub>hs</sub> = Total PMOS Loss (mW)	321.47	= P <sub>ch</sub> + P <sub>sh</sub>
Vf = Schottky Forward Voltage	0.5	PI = Inductor loss (mW)	192.00	= I <sub>OUT</sub> *I <sub>OUT</sub> *ESR <sub>L</sub>
I <sub>CC</sub> = Supply Current (no switch) (mA)	5	PC <sub>IN</sub> = Input Capacitor Loss(mW)	19.54	= ESR <sub>IN</sub> *I <sub>in_rms</sub> *I <sub>in_rms</sub>
ESR <sub>L</sub> = Inductor ESR (mΩ)	12	PI <sub>tot</sub> = Total Power Losses (mW)	1412.84	= P <sub>ic</sub> +P <sub>Is</sub> +P <sub>hs</sub> +PI+P <sub>sch</sub>
		Efficiency (%)	84.32	= V <sub>OUT</sub> *I <sub>OUT</sub> /(V <sub>OUT</sub> *I <sub>OUT</sub> - PI <sub>tot</sub> /1000)*100

Table 2: Design Calculator

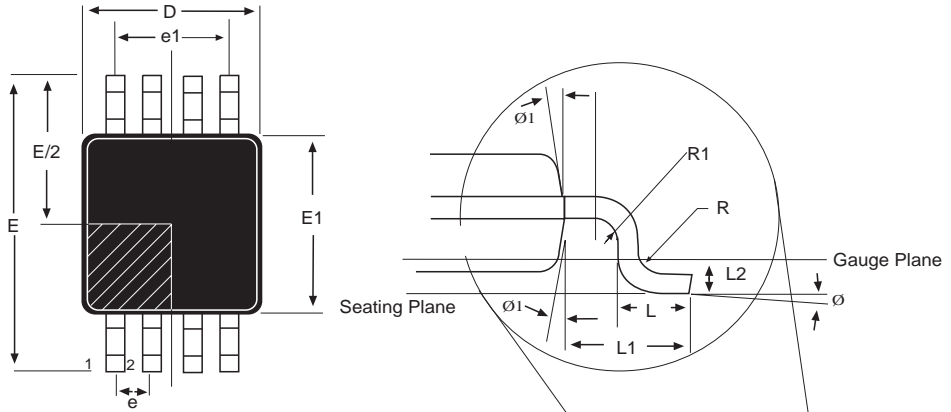

Pin #1 identifier must be indicated within this shaded area ( $D/2 * E1/2$ )

8-PIN MSOP JEDEC MO-187 (AA) Variation	Dimensions in (mm)		
	MIN	NOM	MAX
A	-	-	1.10
A1	0	-	0.15
A2	0.75	0.85	0.95
b	0.22	-	0.38
c	0.08	-	0.23
D	3.00 BSC		
E	4.90 BSC		
E1	3.00 BSC		
e	0.65 BSC		
e1	1.95 BSC		
L	0.40	0.60	0.80
L1	0.95 REF		
L2	0.25 BSC		
N	-	8	-
R	0.07	-	-
R1	0.07	-	-
Ø	0°	-	8°
Ø1	0°	-	15°

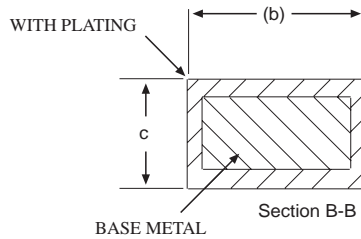
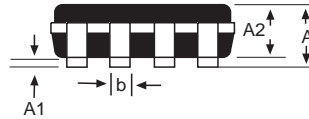

## 8-PIN MSOP

## ORDERING INFORMATION

Part Number	Operating Temperature Range	Package Type
SP6122ACU .....	0°C to 70°C .....	8 Pin MSOP
SP6122ACU/TR .....	0°C to 70°C .....	8 Pin MSOP
SP6122ACU-1.5 .....	0°C to 70°C .....	8 Pin MSOP
SP6122ACU-1.5/TR .....	0°C to 70°C .....	8 Pin MSOP

Available in lead free packaging. To order add "-L" suffix to part number.

Example: SP6122ACU-1.5/TR = standard; SP6122ACU-L-1.5/TR = lead free

/TR = Tape and Reel

Pack quantity is 2,500 for MSOP.



ANALOG EXCELLENCE

**Sipex Corporation Headquarters**  
233 South Hillview Drive  
Milpitas, CA 95035  
TEL: (408) 934-7500  
FAX: (408) 935-7600

Sipex Corporation reserves the right to make changes to any products described herein. Sipex does not assume any liability arising out of the application or use of any product or circuit described herein; neither does it convey any license under its patent rights nor the rights of others.