



PRELIMINARY

SOLID STATE DEVICES, INC.

14830 Valley View Blvd * La Mirada, Ca 90638
Phone: (562) 404-7855 * Fax: (562) 404-1773
ssdi@ssdi-power.com * www.ssdi-power.com

Designer's Data Sheet

**SRM6SBTR
thru
SRM12SBTR**

**60 AMP
600 - 1200 VOLTS
5 μs
STANDARD RECOVERY
RECTIFIER**

SURFACE MOUNT BUTTON

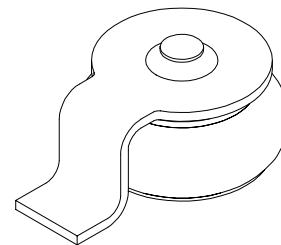

FEATURES:

- Replaces DO-4 and DO-5
- Standard Recovery
- PIV to 1200 Volts
- Low Reverse Leakage
- Hermetically Sealed Void-Free Construction ^{1/}
- Monolithic Single Chip Construction
- High Surge Rating
- Low Thermal Resistance
- Available in Axial Lead Versions and Cathode Button.
Consult Factory.
- TX, TXV and Space Level Screening Available

^{1/} PIND Testing not required on Void-Free Devices per MIL-PRF-19500

Maximum Ratings		SYMBOL	VALUE	UNITS
Peak Repetitive Reverse and DC Blocking Voltage	SRM6SBTR SRM8SBTR SRM10SBTR SRM12SBTR	V_{RRM} V_{RWM} V_R	600 800 1000 1200	Volts
Average Rectified Forward Current (Resistive Load, 60Hz, Sine Wave, $T_C = 100\text{ }^\circ\text{C}$)		I_o	60	Amps
Peak Surge Current (8.3 ms Pulse, Half Sine Wave Superimposed on I_o , allow junction to reach equilibrium between pulses, $T_A = 25\text{ }^\circ\text{C}$)		I_{FSM}	375	Amps
Operating and Storage Temperature		Top & Tstg	-65 TO +175	$^\circ\text{C}$
Maximum Thermal Resistance Junction to Case		$R_{\theta JC}$	1.0	$^\circ\text{C/W}$

NOTE: All specifications are subject to change without notification. SCD's for these devices should be reviewed by SSDI prior to release.

DATA SHEET #: RC0035D

SRM6SBTR thru SRM12SBTR

PRELIMINARY



SOLID STATE DEVICES, INC.

14830 Valley View Blvd * La Mirada, Ca 90638
Phone: (562) 404-7855 * Fax: (562) 404-1773
ssdi@ssdi-power.com * www.ssdi-power.com

Electrical Characteristics		SYMBOL	MAXIMUM	UNITS
Instantaneous Forward Voltage Drop ($T_A = 25^\circ\text{C}$, 300 - 500 μsec Pulse)	$I_F = 20\text{A}_{\text{DC}}$	V_{F1}	1.05	V_{DC}
	$I_F = 60\text{A}_{\text{DC}}$	V_{F2}	1.20	
Reverse Leakage Current (Rated V_R , 300 μsec pulse minimum)	$T_A = 25^\circ\text{C}$	I_{R1}	20	μA
	$T_A = 100^\circ\text{C}$	I_{R2}	2.0	mA
Junction Capacitance ($V_R = 10V_{\text{DC}}$, $T_A = 25^\circ\text{C}$, $f = 1\text{MHz}$)		C_J	250	pF
Reverse Recovery Time ($I_F = 500\text{mA}$, $I_R = 1\text{A}$, $I_{\text{RR}} = 250\text{mA}$, $T_A = 25^\circ\text{C}$)		t_{RR}	5	μsec

CASE OUTLINE: SURFACE MOUNT BUTTON

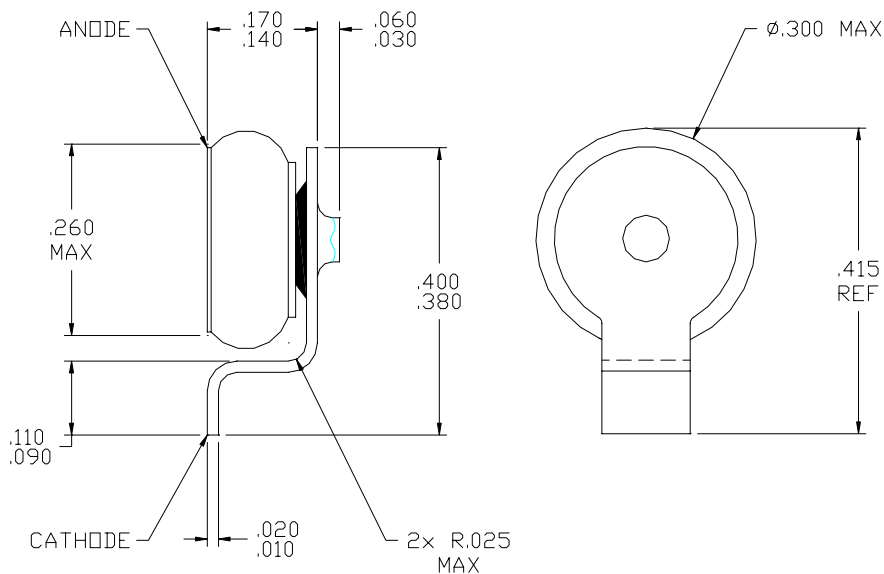

POWER DERATING CURVE

