

UNCONTROLLED DOCUMENT

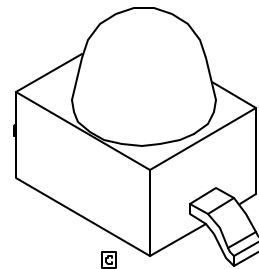

ANODE CATHODE

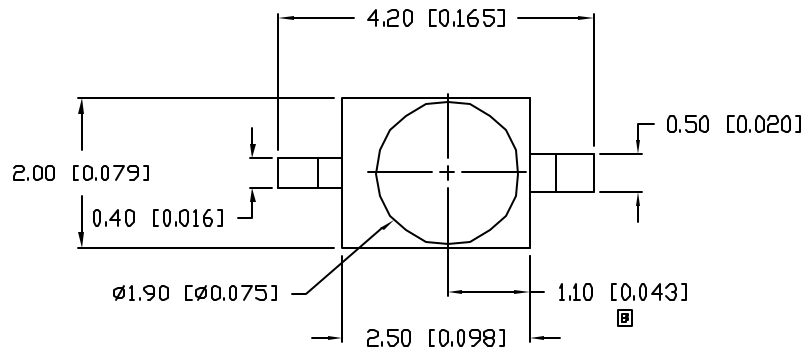
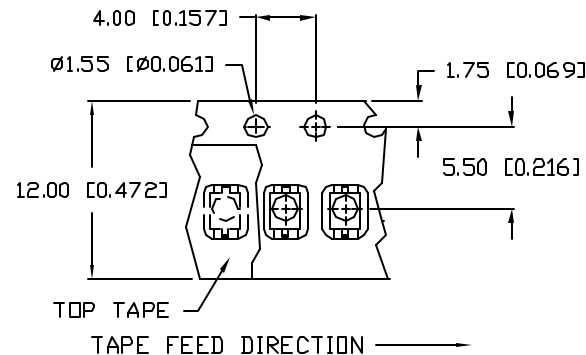
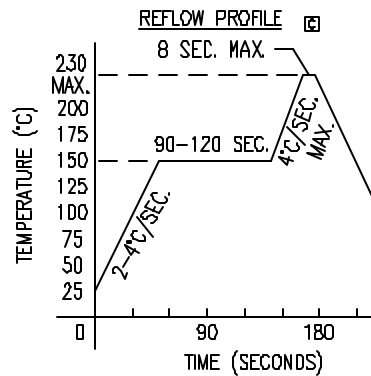
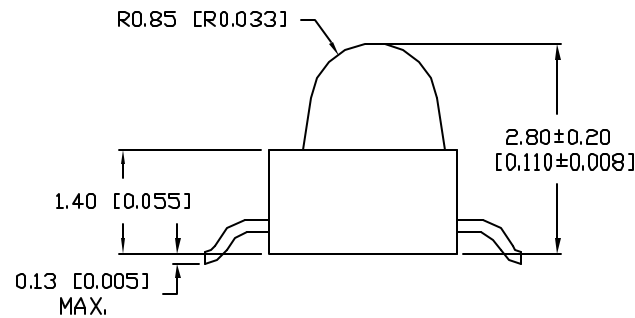

RECOMMENDED SOLDER PAD LAYOUT

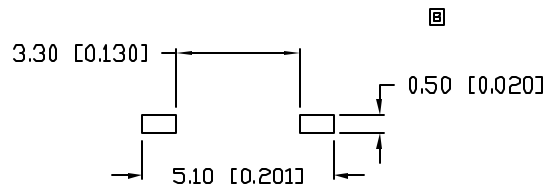

| | | |
|-------------------|-------------------------------------|----------|
| PART NUMBER | | REV. |
| SSL-LXA228IC-TR11 | | C |
| REV. | E.C.N. NUMBER AND REVISION COMMENTS | DATE |
| A | CHG'D WHERE NOTED. | 11.29.94 |
| B | E.C.N. #10550. & #10BRDR | 10.21.99 |
| C | E.C.N. #10695. | 1.5.01 |

ELECTRO-OPTICAL CHARACTERISTICS $T_A=25^\circ\text{C}$ $I_f=20\text{mA}$

| PARAMETER | MIN | TYP | MAX | UNITS | TEST COND |
|--------------------|-------------|-----|-----|----------|----------------------|
| PEAK WAVELENGTH | | 635 | | nm | |
| FORWARD VOLTAGE | | 2.0 | 2.8 | V_f | |
| REVERSE VOLTAGE | 5.0 | | | V_r | $I_f=100\mu\text{A}$ |
| AXIAL INTENSITY | | 80 | | mcd | $I_f=20\text{mA}$ |
| VIEWING ANGLE | | 25 | | 2x theta | |
| EMITTED COLOR: | RED | | | | |
| EPOXY LENS FINISH: | WATER CLEAR | | | | |

LIMITS OF SAFE OPERATION AT 25°C

| PARAMETER | MAX | UNITS |
|-----------------------|------------|-------|
| PEAK FORWARD CURRENT* | 160 | mA |
| STEADY CURRENT | 30 | mA |
| POWER DISSIPATION | 100 | mW |
| DERATE FROM 25°C | -1.2 | mW/°C |
| OPERATING TEMP. | -30 TO +85 | °C |
| STORAGE TEMP. | -40 TO +85 | °C |

* $t < 10\mu\text{s}$

NOTES:

- 1,000 PIECES PER REEL.
- THE CATHODE IS ORIENTED TOWARDS THE TAPE SPROCKET HOLE.

UNCONTROLLED DOCUMENT

*UNLESS OTHERWISE SPECIFIED TOLERANCES PER DECIMAL PRECISION ARE: X=±1 (±0.039), XX=±0.5 (±0.020), XXX=±0.25 (±0.010), XXXX=±0.127 (±0.005). LEAD SIZE=±0.05 (0.002), LEAD LENGTH=±0.75 (±0.030), MIN= +DECIMAL PRECISION -0.00, MAX.= +0.00 -DECIMAL PRECISION

| | |
|--|-------------------|
| REV. | PART NUMBER |
| C | SSL-LXA228IC-TR11 |
| AXIAL LED, GULL WING LEADS, 635nm RED LED, WATER CLEAR LENS, TAPE AND REEL. | |

CONFIDENTIAL INFORMATION
 THE INFORMATION CONTAINED IN THIS DOCUMENT IS THE PROPERTY OF LUMEX INC. EXCEPT AS SPECIFICALLY AUTHORIZED IN WRITING BY LUMEX INC., THE HOLDER OF THIS DOCUMENT SHALL KEEP ALL INFORMATION CONTAINED HEREIN CONFIDENTIAL AND SHALL PROTECT SAME IN WHOLE OR IN PART FROM DISCLOSURE AND DISSEMINATION TO ALL THIRD PARTIES.

RELIABILITY NOTE
 OUR MANY YEARS OF EXPERIENCE DATA ACCUMULATION INDICATE THAT SOLDER HEAT IS A MAJOR CAUSE OF EARLY AND FUTURE FAILURE. PLEASE PAY ATTENTION TO YOUR SOLDERING PROCESS.

| | | |
|-----------|-------------|---|
| | | 290 E. HELEN ROAD PALATINE, IL 60067-6976 PHONE: +1.847.359.2790 US WEB: www.lumex.com TW WEB: www.lumex.com.tw |
| DRAWN BY: | CHECKED BY: | APPROVED BY: |
| ct | | |
| DATE: | 8.31.94 | |
| PAGE: | 1 OF 1 | |
| SCALE: | N/A | |