

SRAM

256K X 16 LOW POWER CMOS STATIC RAM

FEATURES

- Low-power consumption
 - Active: 5mA (I_{CC1})
 - Stand-by: 10uA (CMOS input/output)
- 55/70/100 ns access time
- Equal access and cycle time
- Single +2.7V to 3.6V Power Supply
- TTL compatible , Tri-state output
- Common I/O capability
- Automatic power-down when deselected
- Available in 44-PIN TSOP-II and 48-pin CSP packages

PART NUMBER EXAMPLES

PART NO.	PACKAGE CODE
T15V4M16A-55S	S = TSOP-II
T15V4M16A-70C	C = CSP
T15V4M16A-100C	

GENERAL DESCRIPTION

The T15V4M16A is a very Low Power CMOS Static RAM organized as 262,144 words by 16 bits. That operates on a wide voltage range from 2.7V to 3.6V power supply, Fabricated using high performance CMOS technology, Inputs and three-state outputs are TTL compatible and allow for direct interfacing with common system bus structures. Data retention is guaranteed at a power supply voltage as low as 1.5V.

BLOCK DIAGRAM

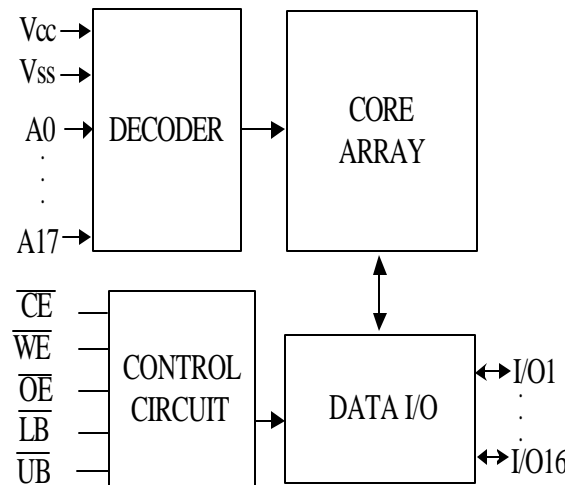

PIN CONFIGURATIONS

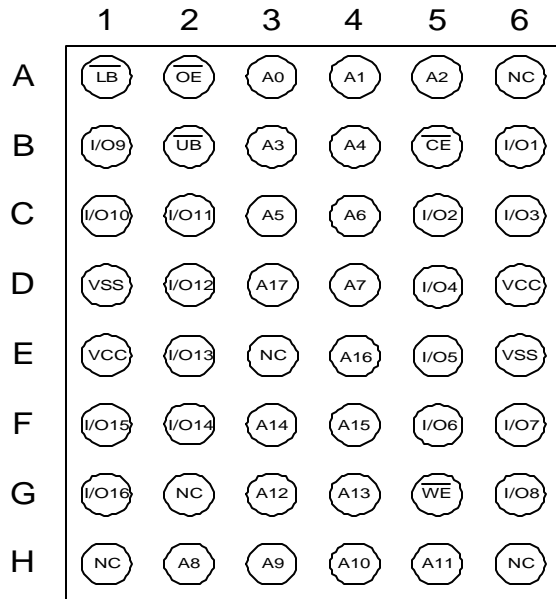
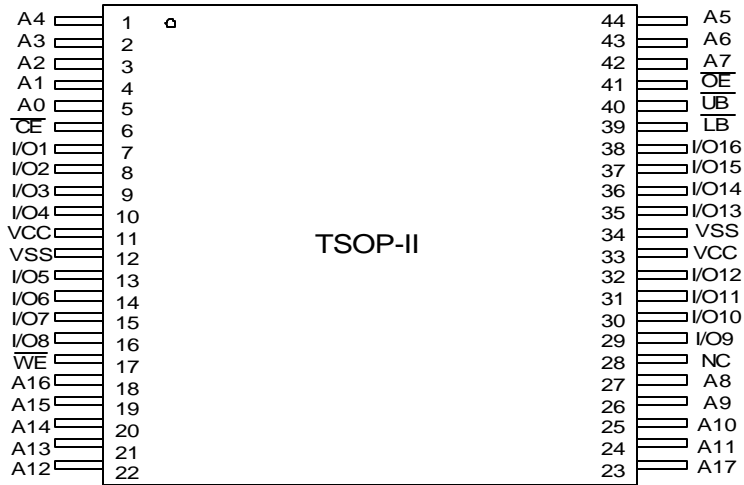

48-Ball CSP TOP VIEW (Ball Down)

PIN DESCRIPTIONS

SYMBOL	DESCRIPTIONS		SYMBOL	DESCRIPTIONS
A0 ~ A17	Address inputs		$\overline{\text{LB}}$	Lower byte (I/O 1~8)
I/O1~I/O16	Data inputs/outputs		$\overline{\text{UB}}$	Upper byte (I/O 9~16)
$\overline{\text{CE}}$	Chip enable		VCC	Power supply
$\overline{\text{WE}}$	Write enable input		VSS	Ground
$\overline{\text{OE}}$	Output enable input		NC	No connection

ABSOLUTE MAXIMUM RATINGS*

PARAMETER	SYM	MIN.	MAX.	UNIT
Voltage on Any Pin Relative to VSS	V _R	-0.2	+3.6 V	V
Power Dissipation	P _D	-	1.0	W
Storage Temperature	T _{STG}	-55	+150	°C
Temperature Under Bias	I _{BIAS}	-40	+85	°C

*Note: Stresses greater than those listed above Absolute Maximum Ratings may cause permanent damage to the device. This is a stress rating only and function operation of the device at these or any other conditions outside those indicated in the operational sections of this specification is not implied. Exposure to absolute maximum rating conditions for extended periods may affect reliability.

TRUTH TABLE

$\overline{\text{CE}}$	$\overline{\text{OE}}$	$\overline{\text{WE}}$	$\overline{\text{LB}}$	$\overline{\text{UB}}$	I/O 1~8	I/O 9~16	MODE	Power
H	X*	X*	X*	X*	High-Z	High-Z	Deselected	Standby
X*	X*	X*	H	H	High-Z	High-Z	Deselected	Standby
L	H	H	L	X*	High-Z	High-Z	Output Disabled	Active
L	H	H	X*	L	High-Z	High-Z	Output Disabled	Active
L	L	H	L	H	Data Out	High-Z	Lower Byte Read	Active
L	L	H	H	L	High-Z	Data Out	Upper Byte Read	Active
L	L	H	L	L	Data Out	Data Out	Word Read	Active
L	X*	L	L	H	Data In	High-Z	Lower Byte Write	Active
L	X*	L	H	L	High-Z	Data In	Upper Byte Write	Active
L	X*	L	L	L	Data In	Data In	Word Write	Active

*Note: X = Don't Care (Must be low or high state), L = Low, H = High

RECOMMENDED OPERATING CONDITIONS

(Ta = -40°C to 85°C**)

PARAMETER	SYM	MIN	TYP	MAX	UNIT
Supply Voltage	V _{CC}	2.7	3.0	3.6	V
	V _{SS}	0.0	0.0	0.0	V
Input Voltage	V _{IH}	2.1	-	V _{CC} +0.3	V
	V _{IL}	-0.2	-	0.6	V

OPERATING CHARACTERISTICS

 (V_{CC} = 2.7 to 3.6V, V_{SS} = 0V, Ta = -40°C to 85°C)

PARAMETER	SYM.	TEST CONDITIONS	-55		-70		-100		UNIT
			Min	Max	Min	Max	Min	Max	
Input Leakage Current	I _{LI}	V _{CC} = Max, V _{IN} = V _{SS} to V _{CC}	-	1	-	1	-	1	uA
Output Leakage Current	I _{LO}	$\overline{\text{CE}} = V_{IH}$ or $\overline{\text{OE}} = V_{IH}$ or $\overline{\text{WE}} = V_{IL}$ V _{IO} = V _{SS} to V _{CC}	-	1	-	1	-	1	uA
Operating Power Supply Current	I _{CC}	$\overline{\text{CE}} = V_{IL}$, $\overline{\text{WE}} = V_{IH}$, $\overline{\text{OE}} = V_{IH}$, V _{IN} = V _{IH} or V _{IL} , I _{OUT} =0mA	-	3	-	3	-	3	mA
Average Operating Current	I _{CC1}	Cycle time=1us, 100% duty, I _{IO} =0mA, $\overline{\text{CE}} \leq 0.2V$, V _{IN} ≥ V _{CC} -0.2V or V _{IN} ≤ 0.2V	-	5	-	5	-	5	mA
	I _{CC2}	Cycle time=min, 100% duty, I _{IO} =0mA, $\overline{\text{CE}} = V_{IL}$, V _{IN} = V _{IH} or V _{IL}	-	45	-	40	-	30	mA
Standby Power Supply Current (TTL Level)	I _{SB}	$\overline{\text{CE}} = V_{IH}$ or $\overline{\text{LB}} = \overline{\text{UB}} = V_{IH}$ other input= V _{IL} or V _{IH}	-	0.3	-	0.3	-	0.3	mA
Standby Power Supply Current (CMOS Level)	I _{SB1}	$\overline{\text{CE}} \geq V_{CC}-0.2V$ or $\overline{\text{LB}} = \overline{\text{UB}} \geq V_{CC}-0.2V$, V _{IN} ≤ 0.2V or V _{IN} ≥ V _{CC} -0.2V	-	10	-	10	-	10	uA
Output Low Voltage	V _{OL}	I _{OL} = 2.1mA	-	0.4	-	0.4	-	0.4	V
Output High Voltage	V _{OH}	I _{OH} = -1.0 mA	2.2	-	2.2	-	2.2	-	V

CAPACITANCE

(f = 1 MHz, Ta = 25°C)

PARAMETER	SYMBOL	CONDITION	MAX.	UNIT
Input Capacitance	C_{IN}	$V_{IN} = 0V$	8	pF
Input/ Output Capacitance	$C_{I/O}$	$V_{IN} = V_{OUT} = 0V$	10	pF

Note: This parameter is guaranteed by device characterization and is not production tested.

AC TEST CONDITIONS

PARAMETER	CONDITIONS
Input Pulse Levels	0.6V to 2.1V
Input Rise and Fall Times	3.0 ns
Input and Output Timing Reference Level	1.4V
Output Load	$C_L = 30pF + 1TTL$ Load(55ns/70ns)
	$C_L = 100pF + 1TTL$ Load(Load for 100ns)

AC TEST LOADS AND WAVEFORM

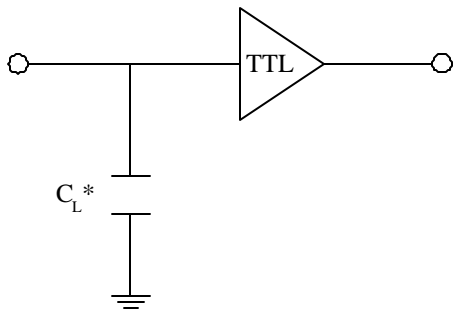

Fig.A * Including Scope and Jig Capacitance

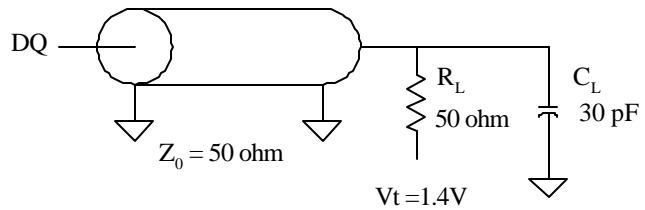

Fig.B Output Load Equivalent

AC CHARACTERISTICS($V_{CC}=2.7$ to $3.6V$, $V_{SS} = 0V$, $T_a = -40^{\circ}C$ to $85^{\circ}C$)

(1) READ CYCLE

PARAMETER	SYM.	-55		-70		-100		UNIT
		Min	Max	Min	Max	Min	Max	
Read Cycle Time	t_{RC}	55	-	70	-	100	-	ns
Address Access Time	t_{AA}	-	55	-	70	-	100	ns
Chip Enable Access Time	t_{ACE}	-	55	-	70	-	100	ns
Output Enable Access Time	t_{OE}	-	30	-	35	-	50	ns
Output Hold from Address Change	t_{OH}	10	-	10	-	10	-	ns
Chip Enable to Output in Low-Z	t_{LZ}	10	-	10	-	10	-	ns
Chip Disable to Output in High-Z	t_{HZ}	-	20	-	25	-	30	ns
Output Enable to Output in Low-Z	t_{OLZ}	5	-	5	-	5	-	ns
Output Disable to Output in High-Z	t_{OHZ}	-	20	-	25	-	30	ns
\overline{LB} , \overline{UB} Access Time	t_{BA}	-	55	-	70	-	100	ns
\overline{LB} , \overline{UB} Enable to Output in Low-Z	t_{BLZ}	10	-	10	-	10	-	ns
\overline{LB} , \overline{UB} Disable to Output in High-Z	t_{BHZ}	-	20	-	25	-	30	ns

(2)WRITE CYCLE

PARAMETER	SYM.	-55		-70		-100		UNIT
		Min	Max	Min	Max	Min	Max	
Write Cycle Time	t_{WC}	55	-	70	-	100	-	ns
Chip Enable to Write End	t_{CW}	50	-	60	-	80	-	ns
Address Valid to Write End	t_{AW}	50	-	60	-	80	-	ns
Address Setup Time	t_{AS}	0	-	0	-	0	-	ns
Write Pulse Width	t_{WP}	45	-	50	-	70	-	ns
Write Recovery Time	t_{WR}	0	-	0	-	0	-	ns
Data Valid to Write End	t_{DW}	25	-	30	-	40	-	ns
Data Hold Time	t_{DH}	0	-	0	-	0	-	ns
Write Enable to Output in High-Z	t_{WHZ}	-	20	-	25	-	30	ns
Output Active from Write End	t_{OW}	5	-	5	-	5	-	ns

TIMING WAVEFORMS

READ CYCLE 1

(Address Controlled, $\overline{CE} = \overline{OE} = V_{IL}$, $\overline{WE} = V_{IH}$, \overline{LB} or/and $\overline{UB} = V_{IL}$)

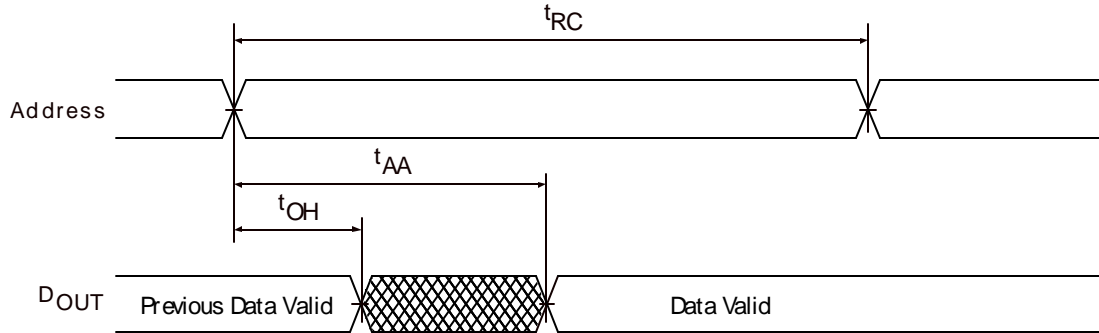

READ CYCLE 2 ($\overline{WE} = V_{IH}$)

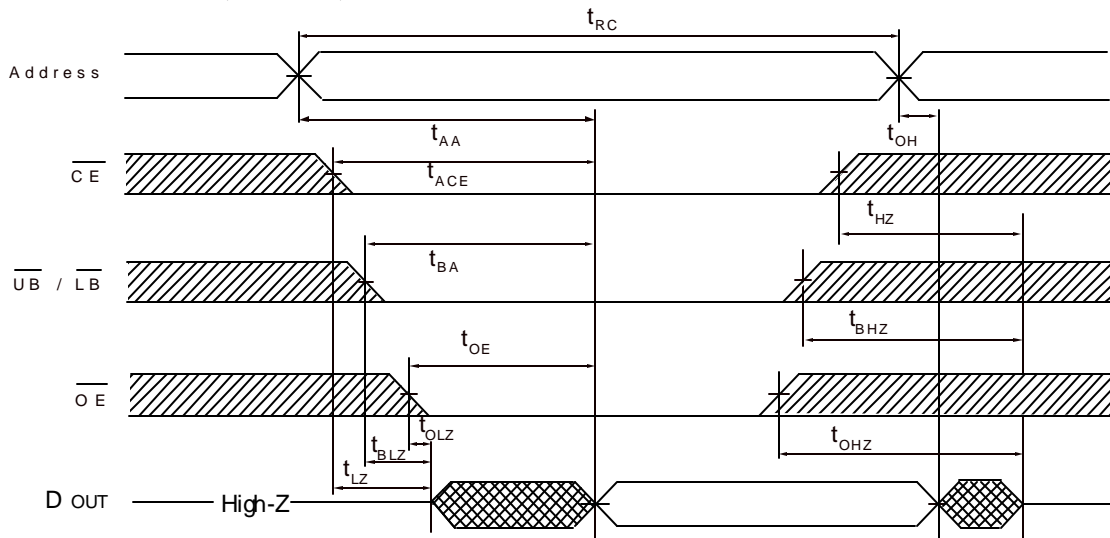

 DON'T CARE
 UNDEFINED

(Chip Enable Controlled)

Notes (READ CYCLE) :

1. \overline{WE} are high for read cycle.
2. All read cycle timing is referenced from the last valid address to the first transition address.
3. t_{HZ} and t_{OHZ} are defined as the time at which the outputs achieve the open circuit condition referenced to V_{OH} or V_{OL} levels.
4. At any given temperature and voltage condition. $t_{HZ}(\max.)$ is less than $t_{LZ}(\min.)$ both for a given device and from device to device interconnection.
5. Transition is measured $\pm 200mV$ from steady state voltage with load. This parameter is sampled and not 100% tested.
6. Device is continuously selected with $\overline{CE} = V_{IL}$.

WRITE CYCLE 1 (\overline{WE} Controlled)

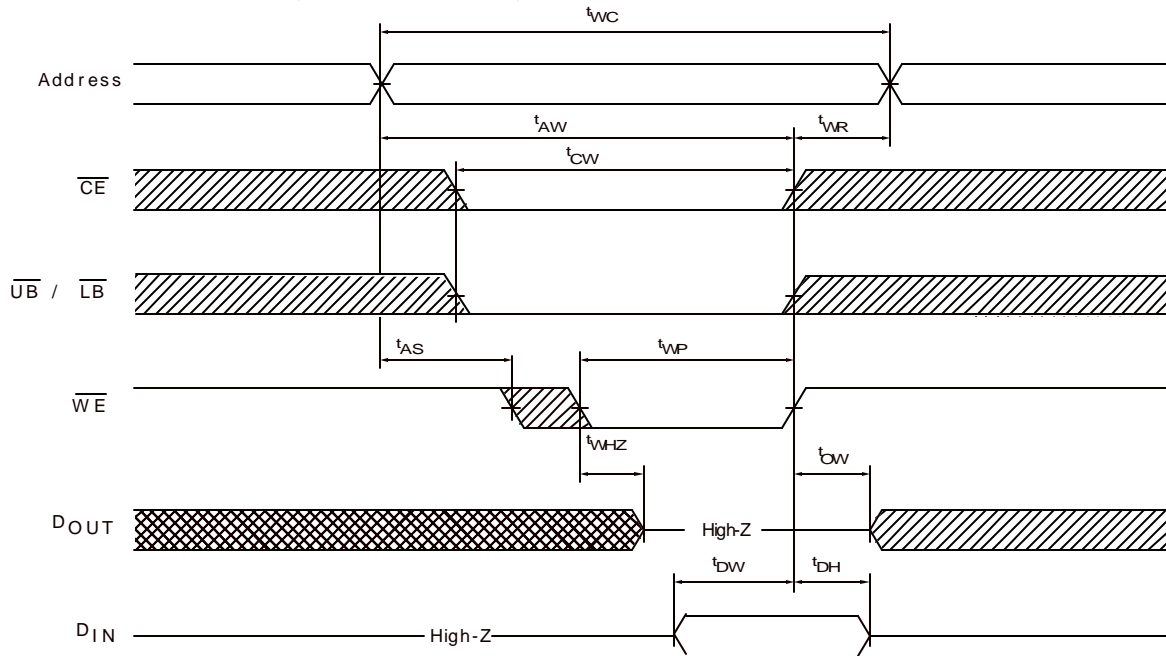

WRITE CYCLE 2 (\overline{CE} Controlled)

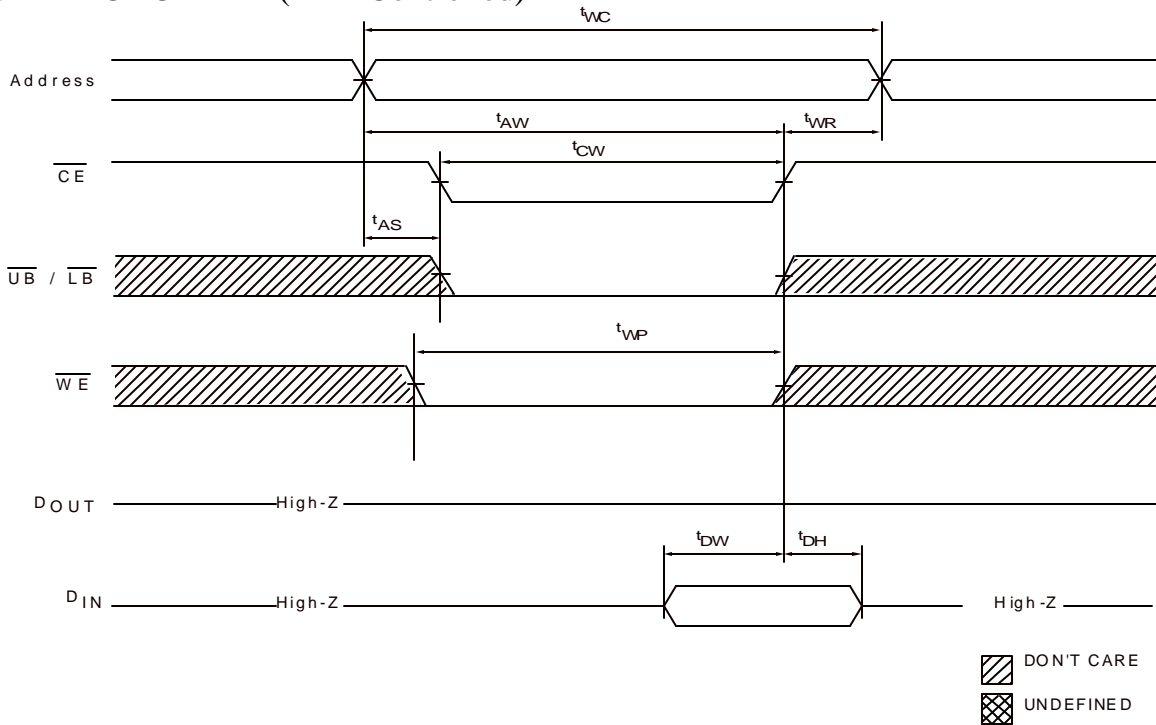

WRITE CYCLE 3 ($\overline{UB}, \overline{LB}$ Controlled)

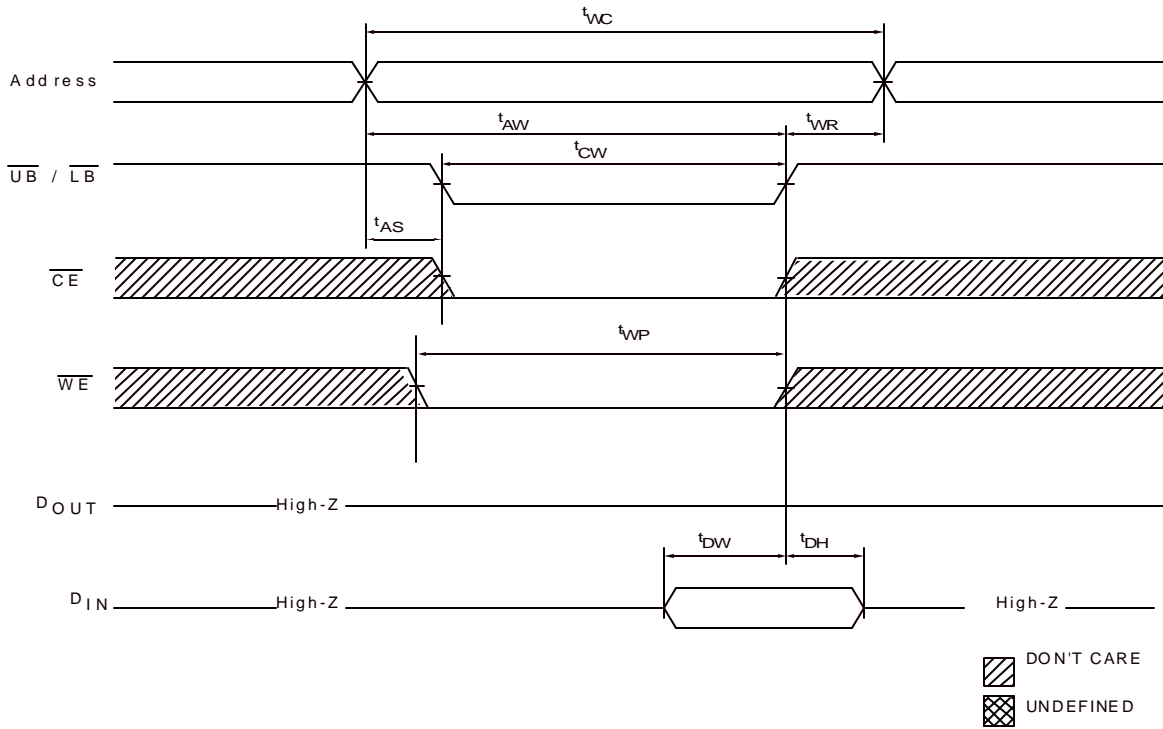

NOTES (WRITE CYCLE) :

1. A write occurs during the overlap of a low \overline{CE} , a low \overline{WE} . A write begins at the latest transition among \overline{CE} goes low, \overline{WE} going low. A write ends at the earliest transition among \overline{CE} going high, \overline{WE} going high. t_{WP} is measured from the beginning of write to the end of write.
2. t_{CW} is measured from the later of \overline{CE} going low to the end of write.
3. t_{AS} is measured from the address valid to the beginning of write.
4. t_{WR} is measured from the end of write to the address change.

DATA RETENTION CHARACTERISTICS

PARAMETER	SYM.	TEST CONDITION	MIN.	MAX.	UNIT
V _{CC} for Data Retention	V _{DR}	$\overline{CE} \geq V_{CC} - 0.2V$	1.5	-	V
Data Retention Current	I _{CCDR}	$V_{IN} \geq V_{CC} - 0.2V$ or	-	10	uA
Chip Deselect to Data Retention Time	t _{CDR}	$V_{IN} \leq 0.2V$	0	-	ns
Operation Recovery Time	t _R		t _{RC}	-	ns

DATA RETENTION WAVEFORM

(T_a = -40°C to 85°C)

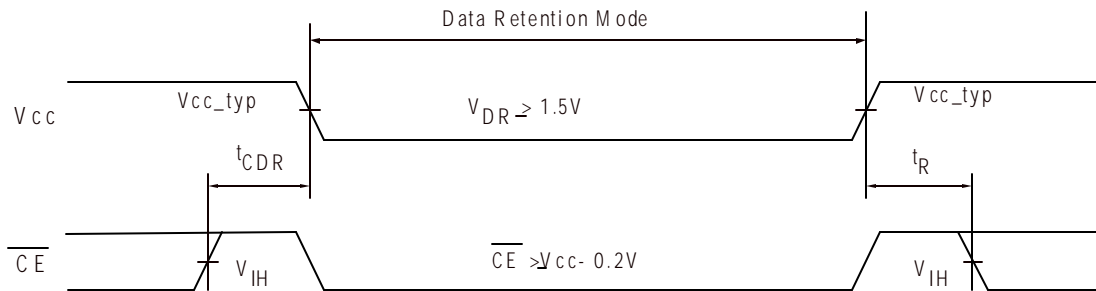

PACKAGE DIMENSIONS
44-LEAD TSOP-II

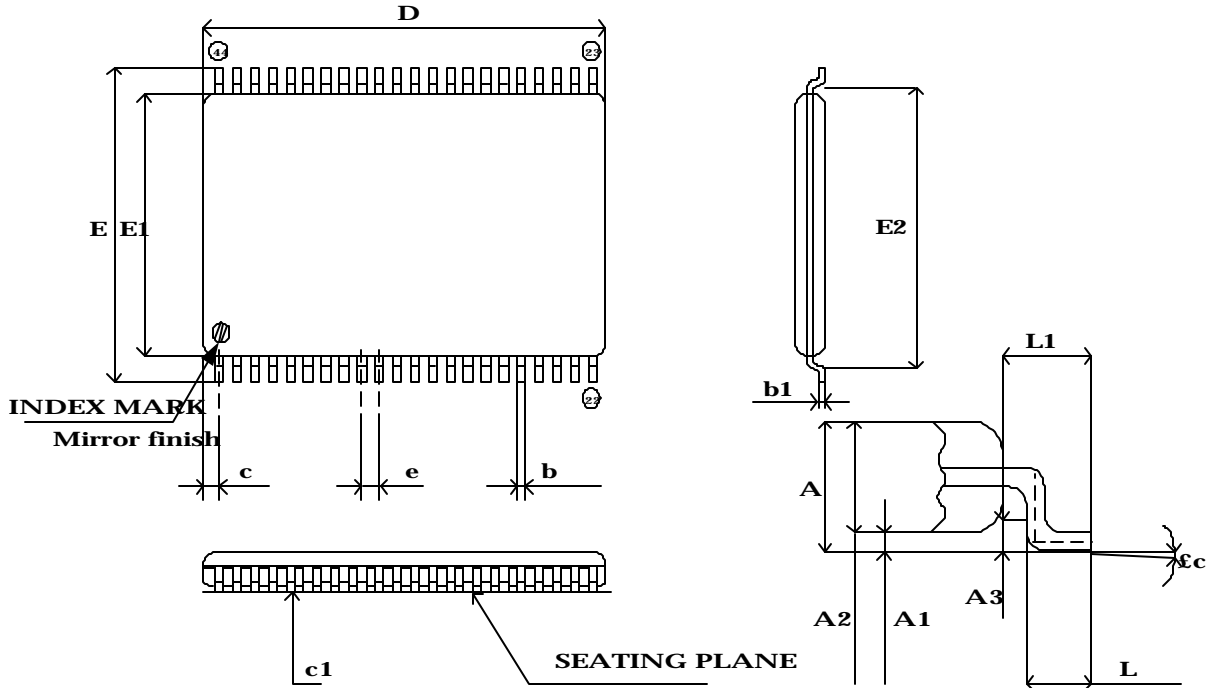

Symbol	Dimension in mm			Dimension in inch		
	Min	Nom	Max	Min	Nom	Max
A	-	-	1.20	-	-	0.047
A1	0.05	-	0.1	0.002	-	0.004
A2	0.95	1.00	1.05	0.037	0.039	0.041
A3	-	0.25	-	-	0.010	-
b	-	0.35(typ)	-	-	0.014(typ)	-
b1	0.10	0.15	0.25	0.004	0.006	0.010
c	-	0.805	-	-	0.032	-
c1	-	0.10	-	-	0.004	-
D	18.31	18.41	18.51	0.721	0.725	0.729
e	-	0.80(typ)	-	-	0.031(typ)	-
E	11.56	11.76	11.96	0.455	0.463	0.471
E1	10.03	10.16	10.29	0.394	0.400	0.405
E2	-	10.76	-	-	0.458	-
L	0.4	0.5	0.6	0.016	0.020	0.024
L1	-	0.8(typ)	-	-	0.032(typ)	-
θ	0	-	8	0	-	8

PACKAGE DIMENSIONS

Units : millimeters

48-pin CSP (8 row x 6 column)

48 BALL FINE PITCH BGA (0.75mm ball pitch)

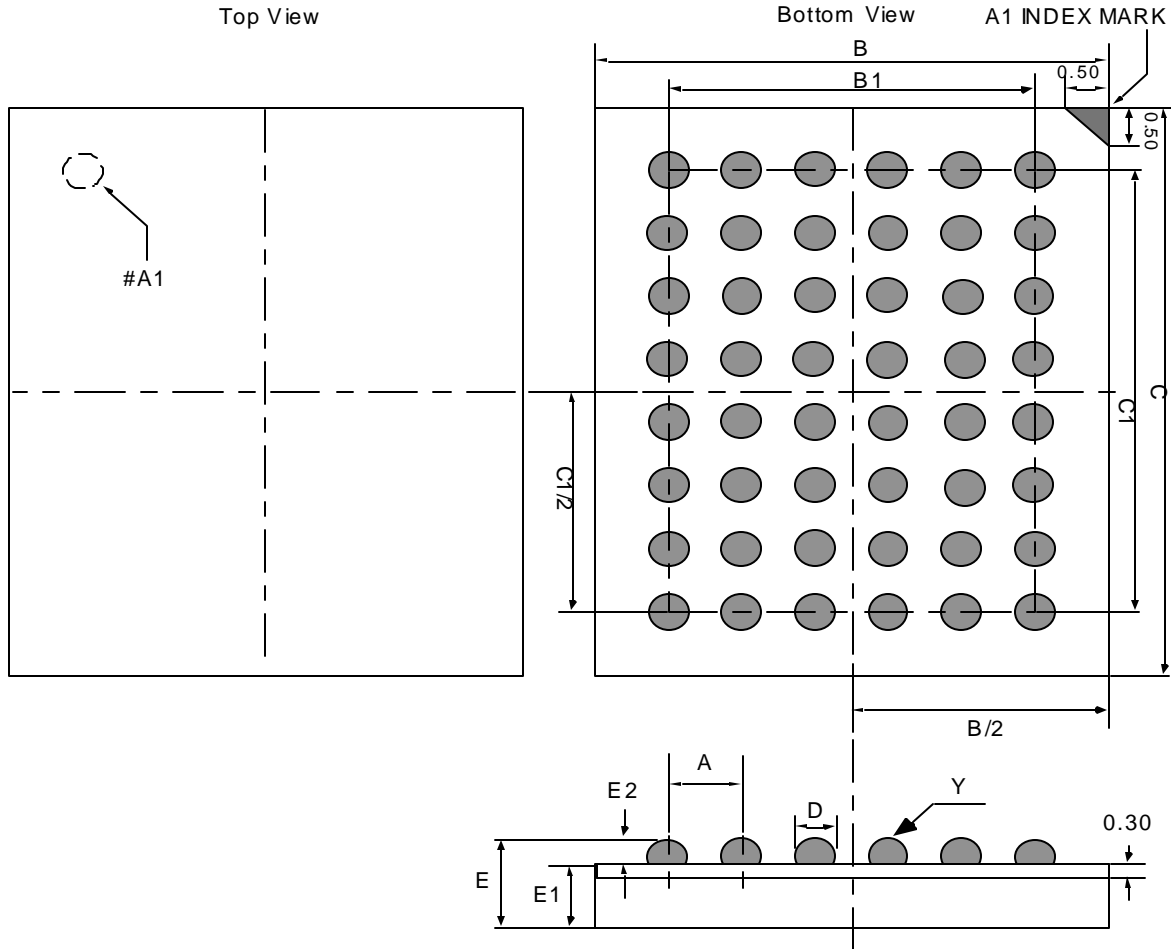

Symbol	min	typ	max
A	-	0.75	-
B	5.95	6.00	6.05
B1	-	3.75	-
C	7.95	8.00	8.05
C1	-	5.25	-
D	0.25	0.30	0.35
E	-	1.10	1.20
E1	-	0.95	-
E2	0.20	0.25	0.30
Y	-	-	0.08

Notes :

1. Bump counts : 48 (8 row x 6column)
2. Bump pitch : (x,y)=(0.75 x 0.75) typ.
3. All tolerance are ± 0.050 unless otherwise specified.
4. 'Y' is coplanarity : 0.08(max)
5. Units : mm