

TAN 250A

250 Watts, 50 Volts, Pulsed
Avionics 960 - 1215 MHz

GENERAL DESCRIPTION

The TAN 250A is a high power COMMON BASE bipolar transistor. It is designed for pulsed systems in the frequency band 960-1215 MHz. The device has gold thin-film metallization and diffused ballasting for proven highest MTTF. The transistor includes input output prematch for broadband capability. Low thermal resistance package reduces junction temperature, extends life.

ABSOLUTE MAXIMUM RATINGS

Maximum Power Dissipation @ 25°C² 575 Watts

Maximum Voltage and Current

BVces Collector to Base Voltage 60 Volts

BVebo Emitter to Base Voltage 4.0 Volts

Ic Collector Current 30 Amps

Maximum Temperatures

Storage Temperature - 65 to + 200°C

Operating Junction Temperature + 200°C

CASE OUTLINE 55AW, STYLE 1

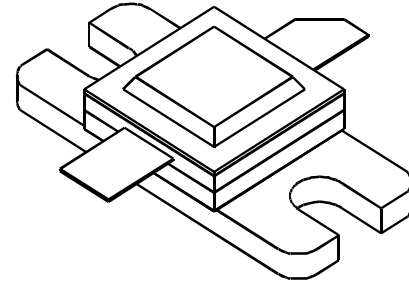

ELECTRICAL CHARACTERISTICS @ 25 °C

SYMBOL	CHARACTERISTICS	TEST CONDITIONS	MIN	TYP	MAX	UNITS
Pout	Power Out	F = 960-1215 MHz	250			Watts
Pin	Power Input	Vcc = 50 Volts			60	Watts
Pg	Power Gain	PW = 20 μsec	6.0	7.0		dB
η_c	Collector Efficiency	DF = 5%		40		%
VSWR	Load Mismatch Tolerance	F = 1090 MHz			5:1	

BVebo	Emitter to Base Breakdown	Ie = 20 mA	4.0			Volts
BVces	Collector to Emitter Breakdown	Ic = 25 mA	60			Volts
h_{FE}	C - Current Gain	Ic = 1A, Vce = 5V	10			
θ_{jc}²	Thermal Resistance	See Chart				°C/W

Note 1: At rated output power and pulse conditions

2: At rated pulse conditions

Issue B, July 1997

GHz TECHNOLOGY INC. RESERVES THE RIGHT TO MAKE CHANGES WITHOUT FURTHER NOTICE. GHz RECOMMENDS THAT BEFORE THE PRODUCT(S) DESCRIBED HEREIN ARE WRITTEN INTO SPECIFICATIONS, OR USED IN CRITICAL APPLICATIONS, THAT THE PERFORMANCE CHARACTERISTICS BE VERIFIED BY CONTACTING THE FACTORY.

GHz Technology Inc. 3000 Oakmead Village Drive, Santa Clara, CA 95051-0808 Tel. 408 / 986-8031 Fax 408 / 986-8120

SERIES INPUT IMPEDANCE vs FREQUENCY

Vcc = 50 V, Po = 250 W

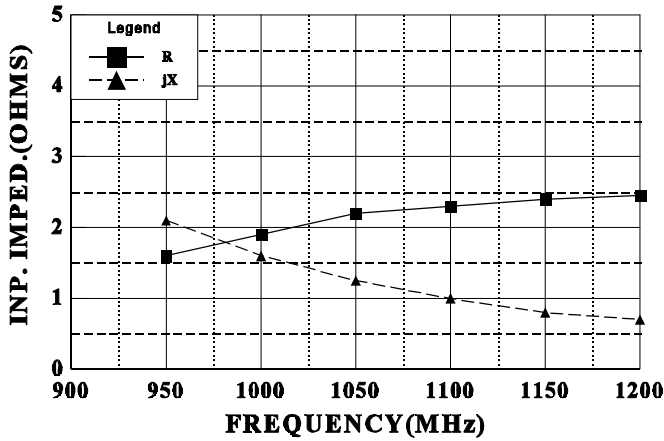

THERMAL RESISTANCE vs PULSE WIDTH

Vcc = 50 V, Pin = 60 W, Duty 5%

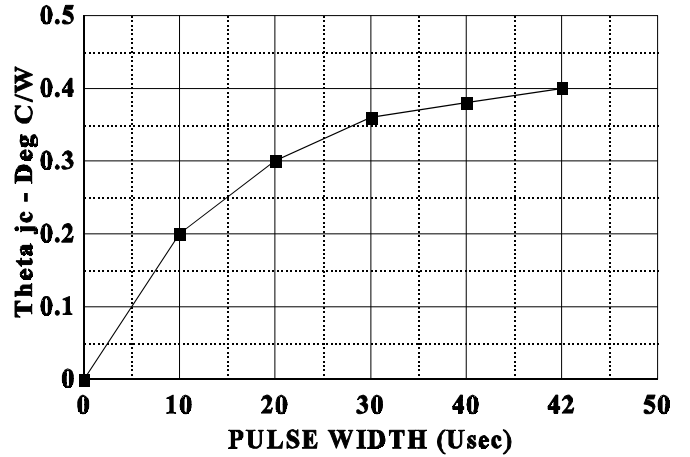

BROADBAND POWER OUTPUT vs FREQU.

Vcc = 50 V, Pin = 60 W

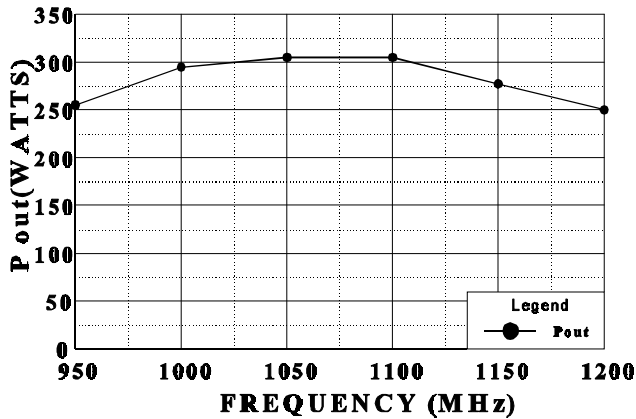

SERIES LOAD IMPEDANCE vs FREQUENCY

Vcc = 50 V, Po = 250 W

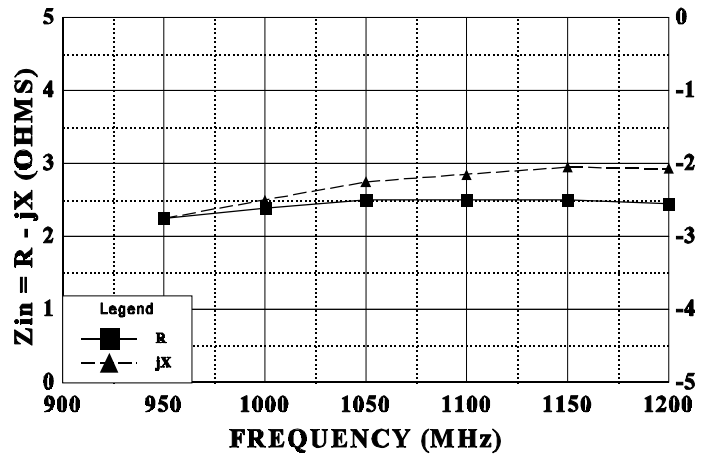

June 1996

GHZ TECHNOLOGY INC. RESERVES THE RIGHT TO MAKE CHANGES WITHOUT FURTHER NOTICE. GHZ RECOMMENDS THAT BEFORE THE PRODUCT(S) DESCRIBED HEREIN ARE WRITTEN INTO SPECIFICATIONS, OR USED IN CRITICAL APPLICATIONS, THAT THE PERFORMANCE CHARACTERISTICS BE VERIFIED BY CONTACTING THE FACTORY.

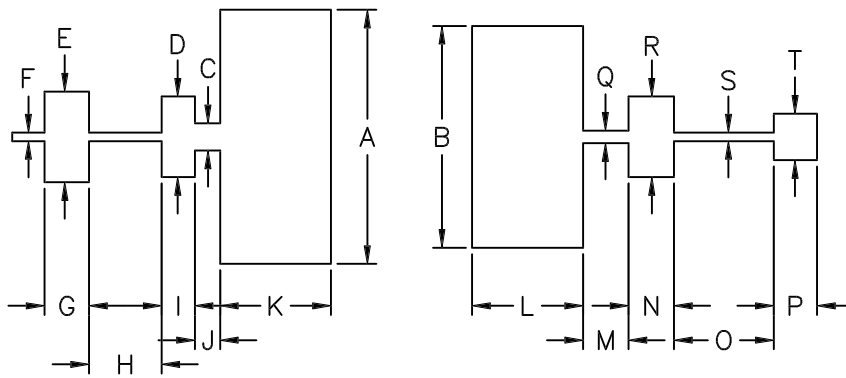

DIM	INCHES
A	1.260
B	1.100
C	.135
D	.400
E	.450
F	.042
G	.220
H	.360
I	.160
J	.125
K	.550
L	.550
M	.225
N	.250
O	.495
P	.215
Q	.062
R	.400
S	.042
T	.230

960-1215 MHz BROADBAND TEST AMPLIFIER

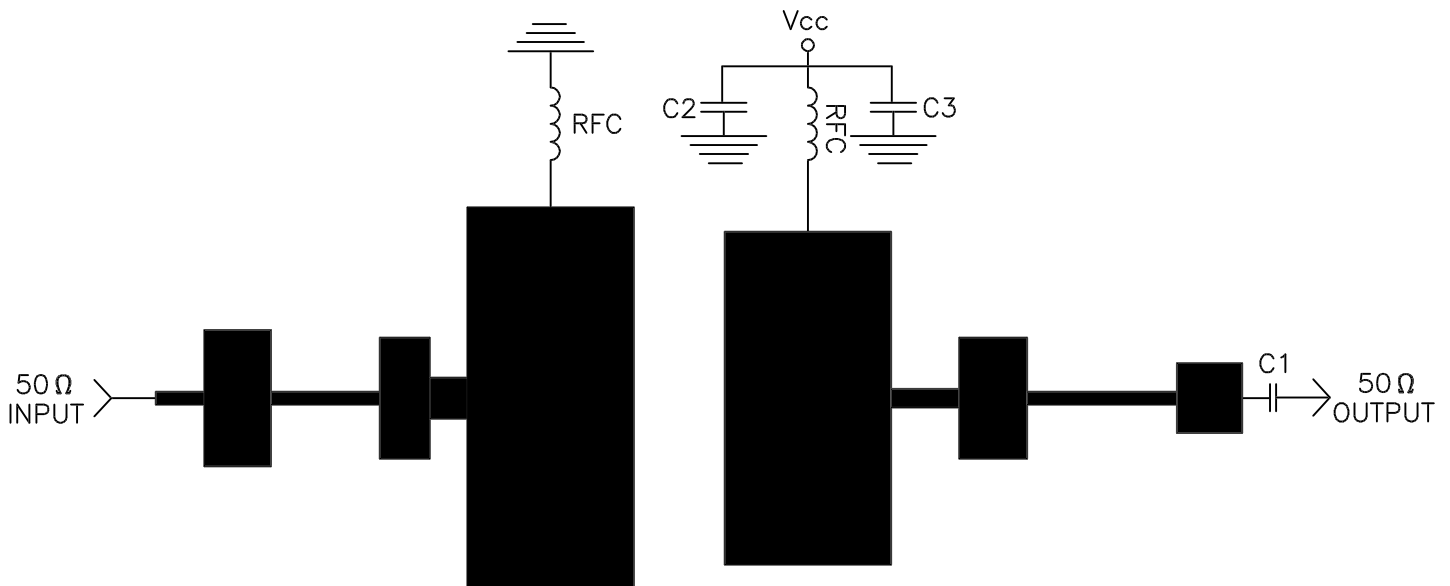

PCB-.015" TFE, 2 oz, CU. type "GT", $\epsilon_r = 2.55$
 C1, C2 - 82pf Chip
 C3-250 MFD