

TOSHIBA BIPOLAR DIGITAL INTEGRATED CIRCUIT MULTI CHIP

TD62M3700F

3 PHASE FULL-WAVE INVERTER

TD62M3700F is low saturation, high current 3 phase full-wave type inverter IC designed especially for battery use motor drive applications.

FEATURES

- High current : $I_O (AVE) = 1.5A$
 $I_O (PEAK) = 3.0A$
- Sealed in 1mm pitch 16pin surface mount package (SSOP16)

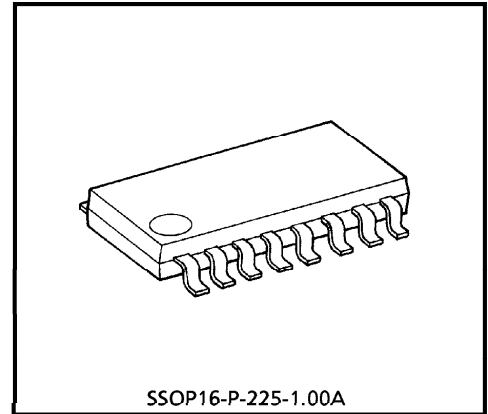

Weight : 0.14g (Typ.)

BLOCK DIAGRAM

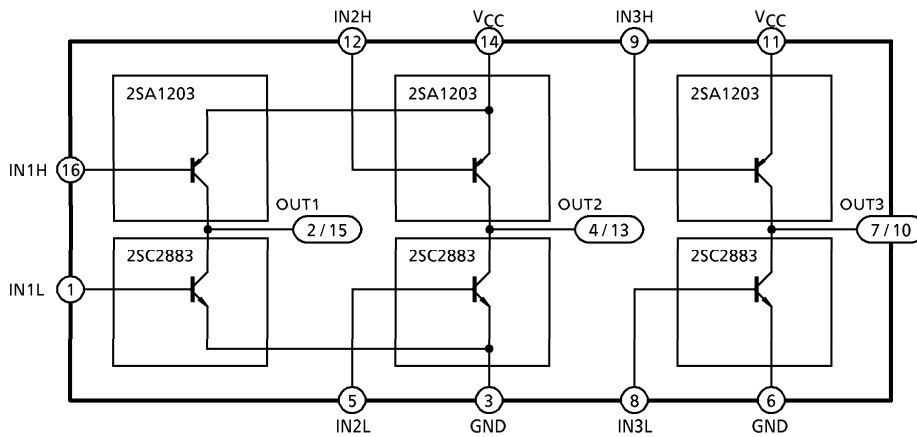

PIN CONNECTION (TOP VIEW)

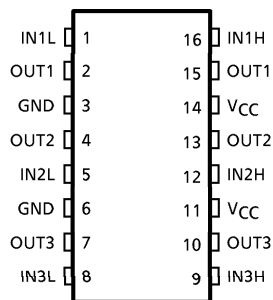

961001EBA2

- TOSHIBA is continually working to improve the quality and the reliability of its products. Nevertheless, semiconductor devices in general can malfunction or fail due to their inherent electrical sensitivity and vulnerability to physical stress. It is the responsibility of the buyer, when utilizing TOSHIBA products, to observe standards of safety, and to avoid situations in which a malfunction or failure of a TOSHIBA product could cause loss of human life, bodily injury or damage to property. In developing your designs, please ensure that TOSHIBA products are used within specified operating ranges as set forth in the most recent products specifications. Also, please keep in mind the precautions and conditions set forth in the TOSHIBA Semiconductor Reliability Handbook.
- The products described in this document are subject to foreign exchange and foreign trade control laws.
- The information contained herein is presented only as a guide for the applications of our products. No responsibility is assumed by TOSHIBA CORPORATION for any infringements of intellectual property or other rights of the third parties which may result from its use. No license is granted by implication or otherwise under any intellectual property or other rights of TOSHIBA CORPORATION or others.
- The information contained herein is subject to change without notice.

MAXIMUM RATINGS (Ta = 25°C)

CHARACTERISTIC	SYMBOL	RATING	UNIT
Power Supply Voltage	V _{CC}	30	V
Breakdown Voltage	V _{CB0}	30	V
	V _{CEO}	30	
	V _{EB0}	5	
Output Current (Average)	I _O (AVE)	1.5	A
Output Current (Peak)	I _O (PEAK)	3.0 (Note 1)	A
Base Current	I _B	± 0.3	A
Power Dissipation	P _D	490 (Note 2)	mW
Junction Temperature	T _j	150	°C
Operating Temperature	T _{opr}	- 40~85	°C
Storage Temperature	T _{stg}	- 55~150	°C

(Note 1) T = 10ms single pulse

(Note 2) Free Air

ELECTRICAL CHARACTERISTICS (Ta = 25°C)

CHARACTERISTIC		SYMBOL	TEST CIRCUIT	TEST CONDITION	MIN.	TYP.	MAX.	UNIT
Current Gain		h _{FE} (1)	—	V _{CE} = - 2V, I _C = - 0.5A	160	—	320	—
		h _{FE} (2)	—	V _{CE} = 0.4V, I _C = 0.2A	160	—	600	
h _{FE} Ratio		h _{FE} (1) / h _{FE} (2)	—	V _{CE} = 0.4V, I _C = 30mA / V _{CE} = 0.4V, I _C = 0.2A	0.75	—	1.25	—
Saturation Voltage	Upper Side	V _{CE} (sat)	—	I _C = - 0.5A, I _B = - 5.0mA	—	- 0.35	- 0.50	V
				I _C = - 1.5A, I _B = - 30mA	—	—	- 2.0	
	Lower Side			I _C = 0.5A, I _B = 5.0mA	—	0.2	0.35	
				I _C = 1.5A, I _B = 30mA	—	—	2.0	
				Summing Total	I _C = 0.5A, I _B = 5.0mA	—	0.55	
I _C = 1.5A, I _B = 30mA	—	—	4.0					
Transition Frequency		f _T	—	V _{CE} = 2V, I _C = 0.5A	—	120	—	MHz
Leakage Current	Upper Side	I _{OL}	—	V _{CC} = - 30V	—	0	- 5	μA
	Lower Side			V _{CC} = 30V	—	0	5	
Base-Emitter Forward Voltage	Upper Side	V _{BE} (PNP)	—	V _{CE} = - 1V, I _C = - 2A	—	- 0.84	- 1.5	V
	Lower Side	V _{BE} (NPN)	—	V _{CE} = 1V, I _C = 2A	—	0.84	1.5	

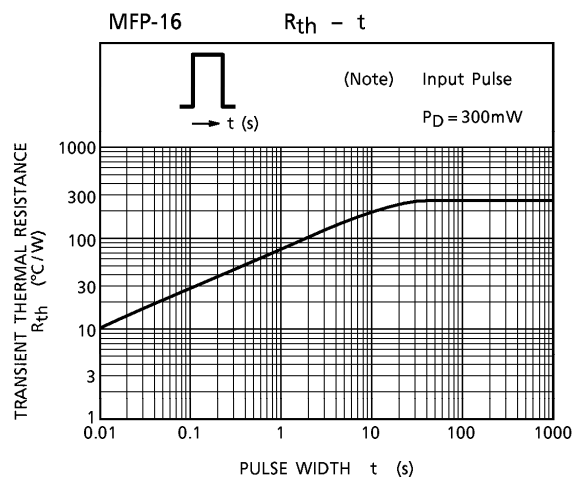
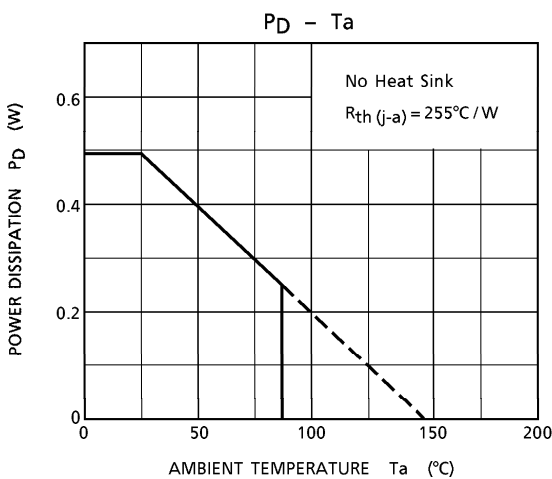
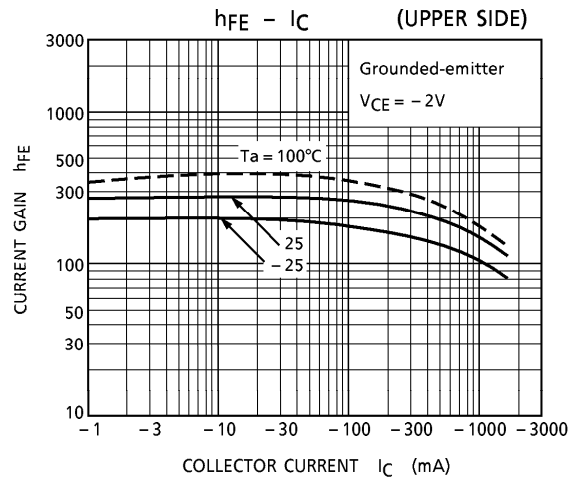
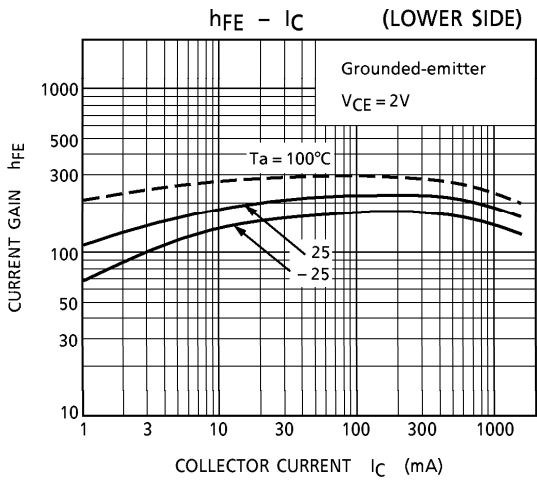
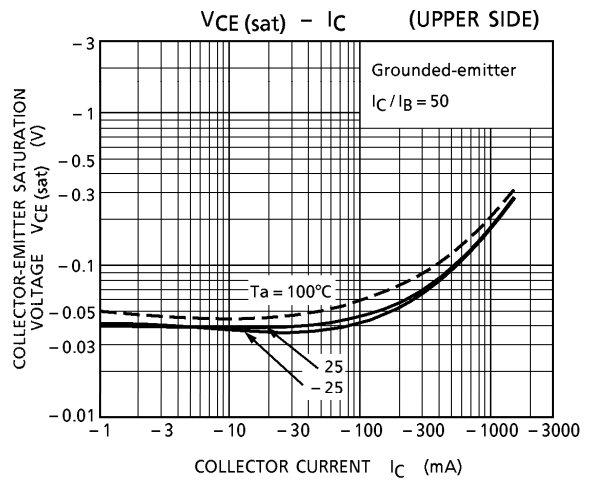
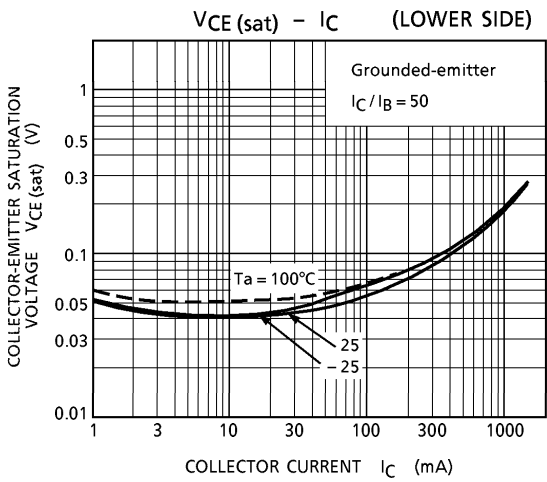

PRECAUTIONS for USING

Utmost care is necessary in the design of the output line, V_{CC} and GND line since IC may be destroyed due to short-circuit between outputs, air contamination fault, or fault by improper grounding.

OUTLINE DRAWING
SSOP16-P-225-1.00A

Unit : mm

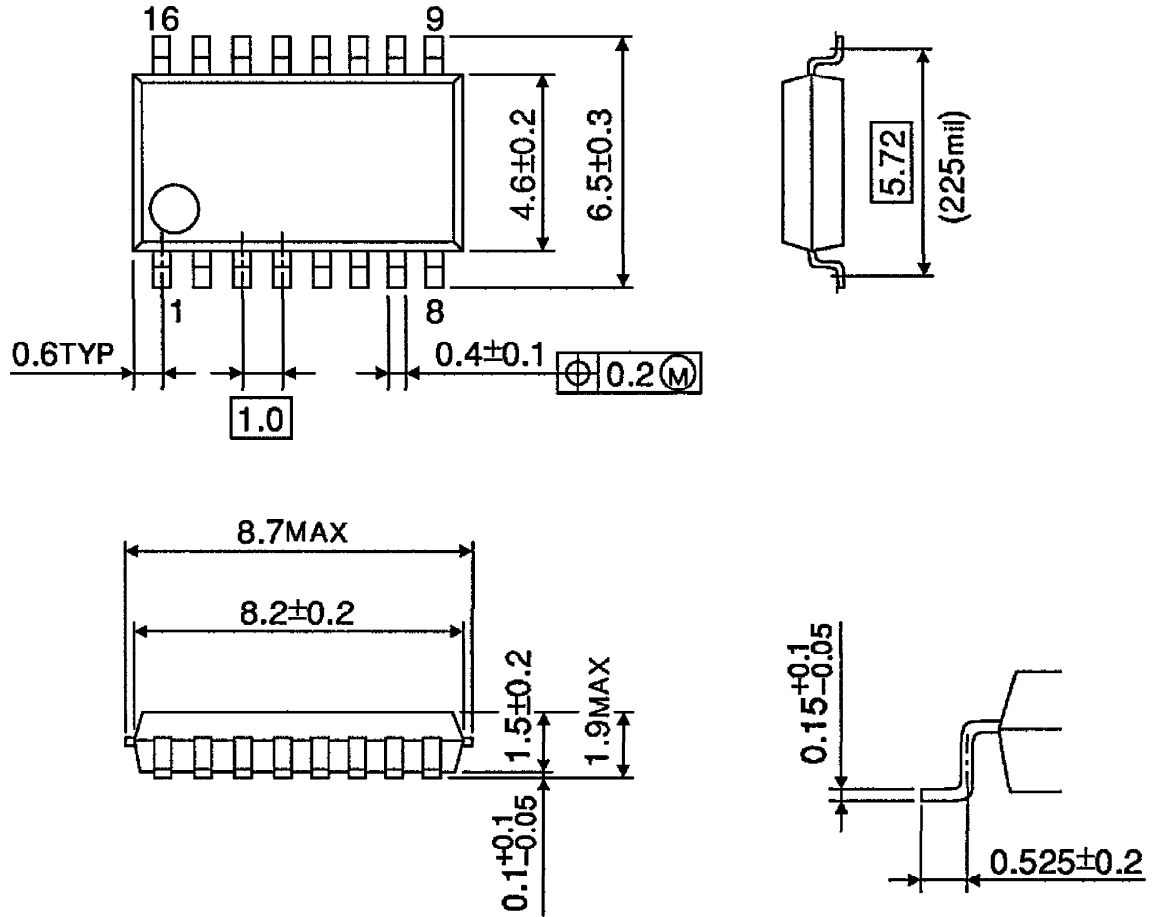

Weight : 0.14g (Typ.)