

Features

- **Advanced performance**
- **Higher sensitivity**
- **Symmetrical thresholds**
- **High piezo resistivity**
- **Reduced power consumption**
- **South and north pole pre-induction possible**
- AC coupled
- Digital output signal
- Two-wire interface
- Large temperature range
- Large airgap
- Low cut-off frequency
- Protection against reversed polarity

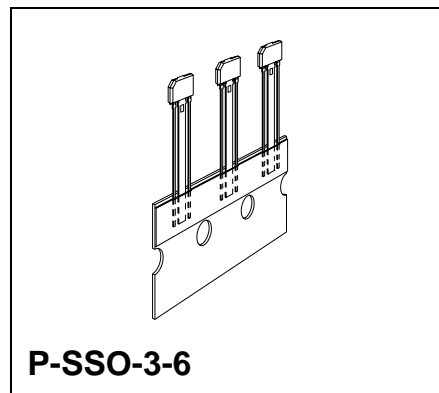

Type	Ordering Code	Package
▼ TLE 4923	Q62705-K408	P-SSO-3-6
▼ New type		

The differential Hall effect sensor TLE 4923 is compatible to the TLE 4921-3U, except for having a 2-wire interface. The TLE 4923 provides high sensitivity, a superior stability over temperature and symmetrical thresholds in order to achieve a stable duty cycle. TLE 4923 is particularly suitable for rotational speed detection and timing applications of ferromagnetic toothed wheels such as in anti-lock braking systems, transmissions, crankshafts, etc. The integrated circuit (based on Hall effect) provides a digital signal output with frequency proportional to the speed of rotation. Unlike other rotational sensors differential Hall ICs are not influenced by radial vibration within the effective airgap of the sensor and require no external signal processing.

Pin Configuration

(top view)

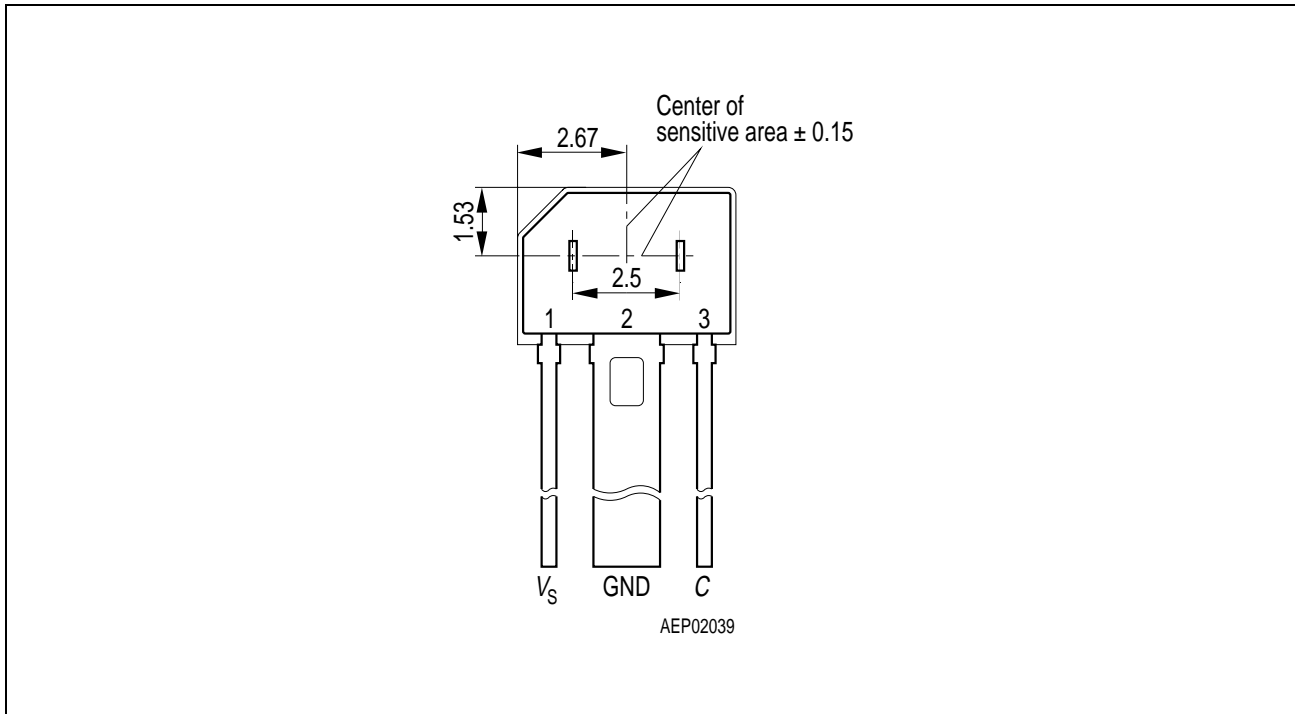

Figure 1

Pin Definitions and Functions

Pin No.	Symbol	Function
1	V_s	Supply voltage
2	GND	Ground
3	C	Capacitor

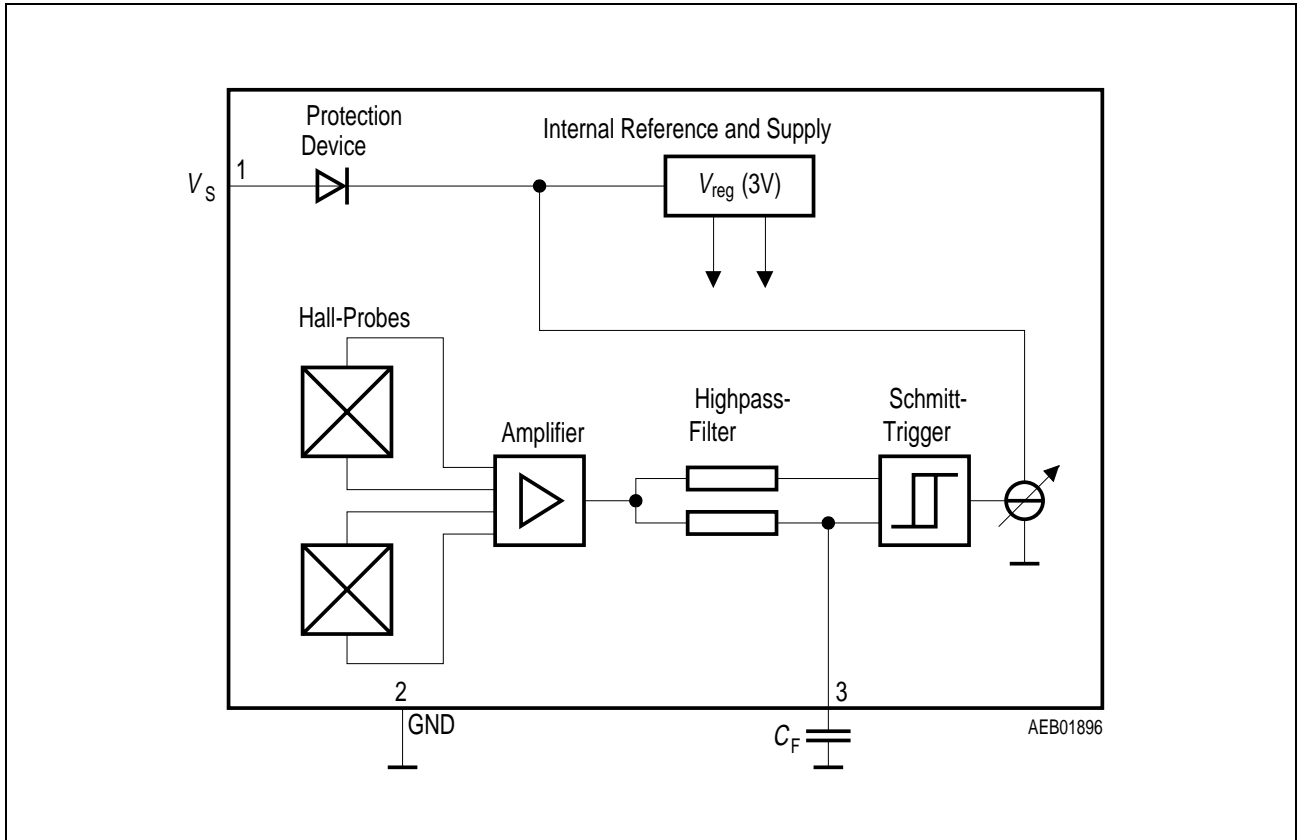

Figure 2 Block Diagram

Functional Description

The Differential Hall sensor IC detects the motion and position of ferromagnetic and permanent magnet structures by measuring the differential flux density of the magnetic field. To detect ferromagnetic objects the magnetic field must be provided by a back biasing permanent magnet (**south or north** pole of the magnet attached to the rear unmarked side of the IC package).

Using an external capacitor the generated Hall voltage signal is slowly adjusted via an active high pass filter with low frequency cut-off. This causes the output to switch into a biased mode after a time constant is elapsed. The time constant is determined by the external capacitor. Filtering avoids aging and temperature influence from Schmitt-trigger input and eliminates device and magnetic offset.

The TLE 4923 can be exploited to detect toothed wheel rotation in a rough environment. Jolts against the toothed wheel and ripple have no influence on the output signal.

The on and off state of the IC are indicated by high and low current consumption.

Circuit Description (see Figure 2)

The TLE 4923 is comprised of a supply voltage reference, a pair of Hall probes spaced at 2.5 mm, differential amplifier, filter for offset compensation, Schmitt-trigger, and a switched current source.

The TLE 4923 was designed to have a wide range of application parameter variations. Differential fields up to ± 40 mT can be detected without influence to the switching performance. The pre-induction field can either come from a magnetic south or north pole, whereby the field strength up to 500 mT or more will not influence the switching points¹⁾. The improved temperature compensation enables a superior sensitivity and accuracy over the temperature range. Finally, the optimized piezo compensation and the integrated dynamic offset compensation enable easy manufacturing and elimination of magnet offsets.

Protection is provided at the input/supply (pin 1) for reverse polarity.

¹⁾ Differential bias fields exceeding ± 20 mT, e. g. caused by a misaligned magnet, should be avoided.

Absolute Maximum Ratings

Parameter	Symbol	Limit Values		Unit	Remarks
		min.	max.		
Supply voltage	V_S	- 18 ¹⁾	24	V	
Capacitor voltage	V_C	- 0.3	3	V	
Junction temperature	T_j		150	°C	5000 h
Junction temperature	T_j		160	°C	2500 h
Junction temperature	T_j		170	°C	500 h
Junction temperature	T_j		190	°C	4 h
Storage temperature	T_S	- 40	150	°C	
Thermal resistance	$R_{th JA}$		190	K/W	²⁾

¹⁾ Reverse current drawn by the device < 10 mA

²⁾ Can be reduced significantly by further packaging process, e. g. overmolding.

The device is ESD protected up to 2 kV (HL test procedure)

Note: Stresses above those listed here may cause permanent damage to the device. Exposure to absolute maximum rating conditions for extended periods may affect device reliability.

Operating Range

Parameter	Symbol	Limit Values		Unit	Remarks
		min.	max.		
Supply voltage	V_S	4.5	18	V	
Junction temperature	T_j	- 40	190	°C	
Pre-induction	B_0	- 500	500	mT	At Hall probe; independent of magnet orientation
Differential induction	ΔB	- 40	40	mT	

Note: Unless otherwise noted, all temperatures refer to junction temperature.

In the operating range the functions given in the circuit description are fulfilled.

AC/DC Characteristics

The device characteristics listed below are guaranteed in the full operating range.

Parameter	Symbol	Limit Values			Unit	Test Condition	Test Circuit
		min.	typ.	max.			
Supply current	I_S	3.1	4.1	5.3	mA		1
		8.1	10.5	13.6	mA		1
Supply current difference	$I_{son} - I_{soff}$	5.0	6.4	8.3	mA		1
Supply current ratio	I_{SON} / I_{SOFF}	2	2.4	3			1
Center of switching points: $(\Delta B_{OP} + \Delta B_{RP}) / 2$	ΔB_m	- 0.5	0	0.5	mT	$\Delta B = 2.0 \text{ mT}$, $f = 200 \text{ Hz}$, $- 40 \text{ }^\circ\text{C} < T_j \leq 150 \text{ }^\circ\text{C}$ ^{1) 2)}	2
Center of switching points: $(\Delta B_{OP} + \Delta B_{RP}) / 2$	ΔB_m	- 0.7	0	0.7	mT	$\Delta B = 2.0 \text{ mT}$, $f = 200 \text{ Hz}$, $150 \text{ }^\circ\text{C} < T_j < 190 \text{ }^\circ\text{C}$ ^{1) 2)}	2
Hysteresis	ΔB_{hy}	1	1.5	2.2	mT	$\Delta B = 2.0 \text{ mT}$, $f = 200 \text{ Hz}$ ³⁾	2
Current rise time	t_r			0.5	μs		2
Current fall time	t_f			0.5	μs		2
Delay time ⁴⁾	t_{dop}			25	μs	$f = 10 \text{ kHz}$, $\Delta B = 5 \text{ mT}$	2
	t_{drp}			10	μs		
	$t_{dop} - t_{drp}$			15	μs		
Filter input resistance	R_C	35	43	52	k Ω	$25 \text{ }^\circ\text{C} \pm 2 \text{ }^\circ\text{C}$	1
Filter sensitivity to ΔB	S_C		8.5		mV/ mT	$25 \text{ }^\circ\text{C} \pm 2 \text{ }^\circ\text{C}$	1
Filter bias voltage	V_C	1.6	2.0	2.4	V	$\Delta B = 0$	1
Frequency	f	⁵⁾		10000	Hz	$\Delta B = 5 \text{ mT}$	2
Resistivity against mechanical stress (piezo) ⁶⁾	ΔB_m	- 0.1		0.1	mT	F = 2 N	2
	ΔB_{Hy}	- 0.1		0.1	mT		

AC/DC Characteristics (cont'd)

The device characteristics listed below are guaranteed in the full operating range.

Parameter	Symbol	Limit Values			Unit	Test Condition	Test Circuit
		min.	typ.	max.			
Power Supply Rejection Ratio (PSRR)	V_{PSRR}	10			V	V_S modulated with V_{PSRR} , $f_{\text{PSRR}} = 10 \text{ kHz}$, $t_{\text{r,PSRR}} = 1 \mu\text{s}$, $\Delta B = 0$, only 1 transition may occur	2 ⁷⁾

1) For ΔB values larger than $\pm 10 \text{ mT}$ this value may exceed the limits as follows: $|\Delta B_m| < |0.05 \times \Delta B|$

2) Leakage currents at pin 3 should be avoided. The bias shift of B_m caused by a leakage current I_L can be calculated by: $\Delta B_m = \frac{I_L \times R_C(T)}{S_C(T)}$. See also the typical curves on **page 17**.

3) Differential pre-induction (e.g. by magnetic misalignment) has to be smaller than 20 mT.

4) For definition see **Figure 6**.

5) Depends on filter capacitor C_F . The cut-off frequency is given as $f = \frac{1}{2 \times \pi \times R_C \times C_F}$. The switching points are guaranteed over the whole frequency range, but amplitude modification and phase shift have to be taken into account due to the 1st order highpass filter.

6) For definition see **Figure 7**.

7) For definition see **Figure 5**.

Note: The listed characteristics are ensured over the operating range of the integrated circuit. Typical characteristics specify mean values expected over the production spread. If not otherwise specified, typical characteristics apply at $T_j = 25^\circ\text{C}$ and the given supply voltage.

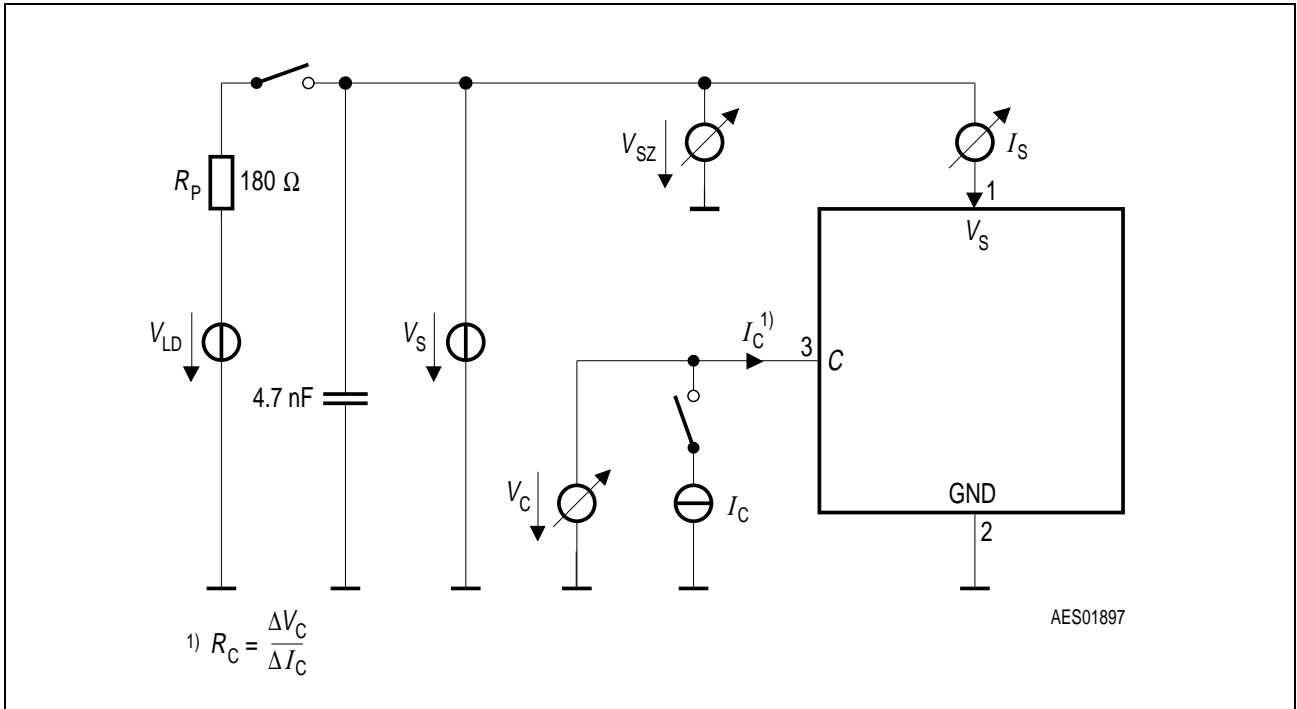

Figure 3 Test Circuit 1

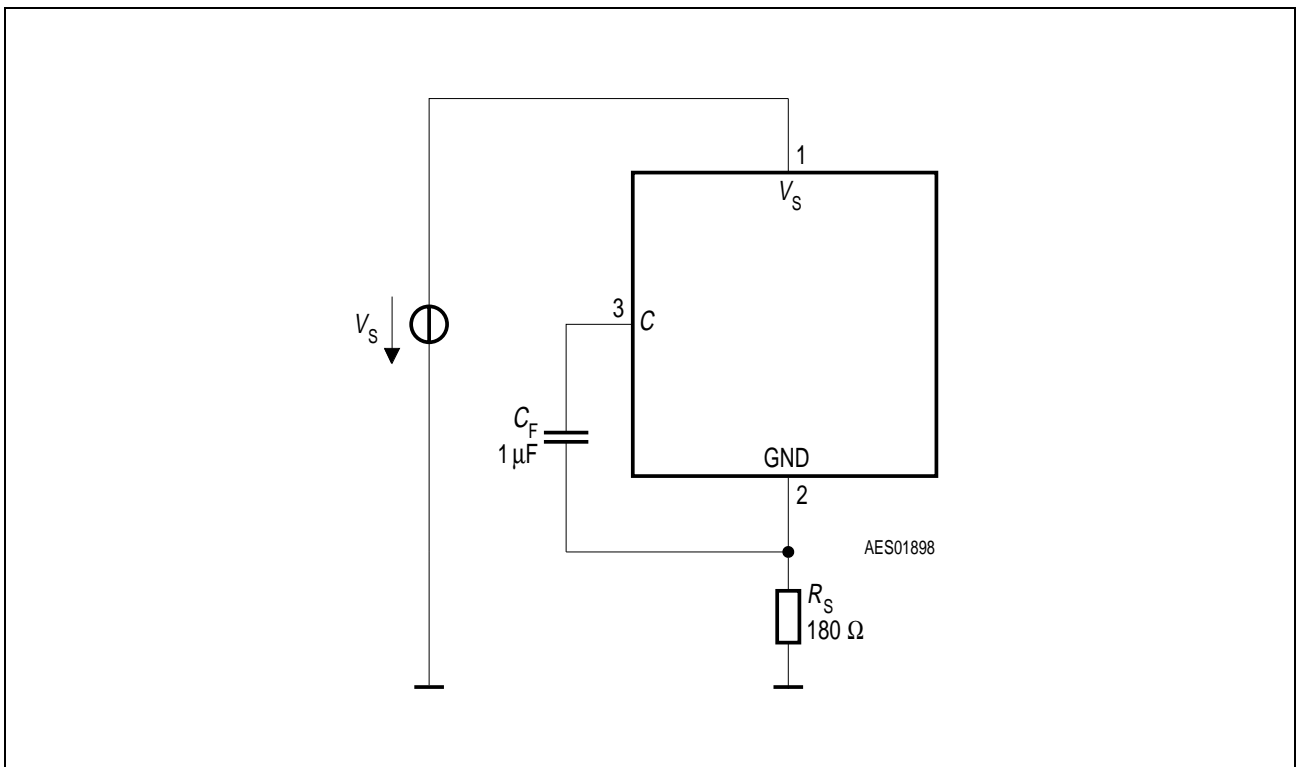

Figure 4 Test Circuit 2

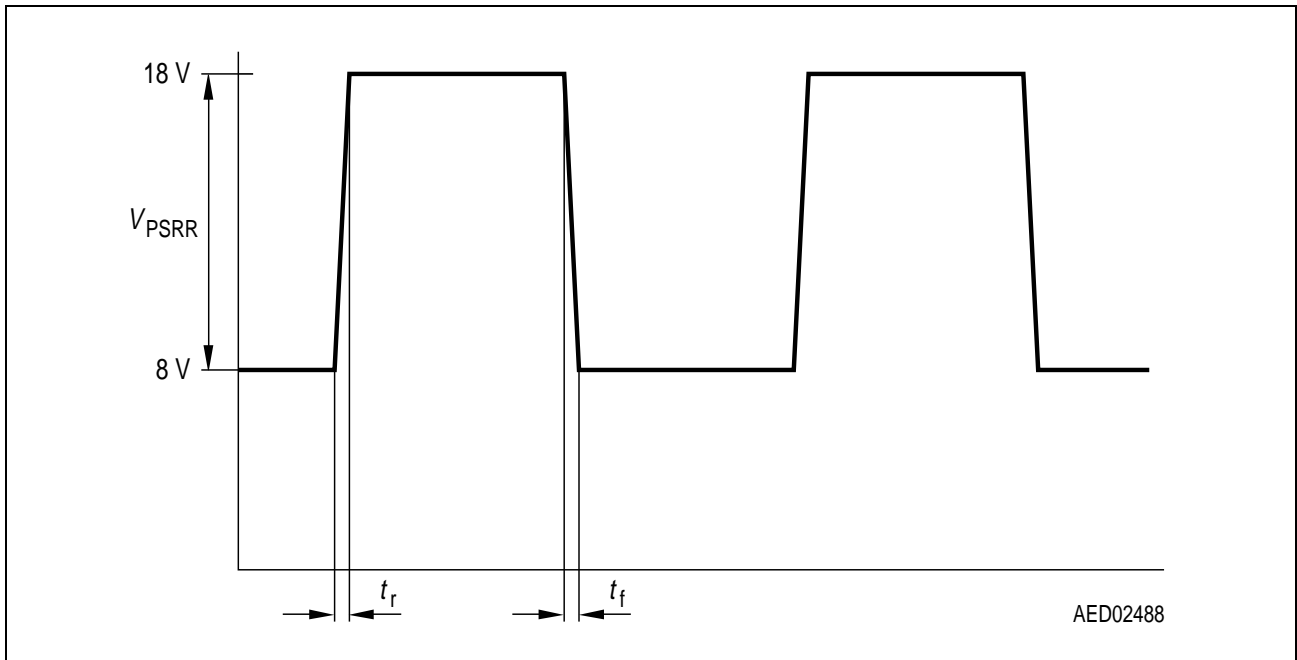

Figure 5

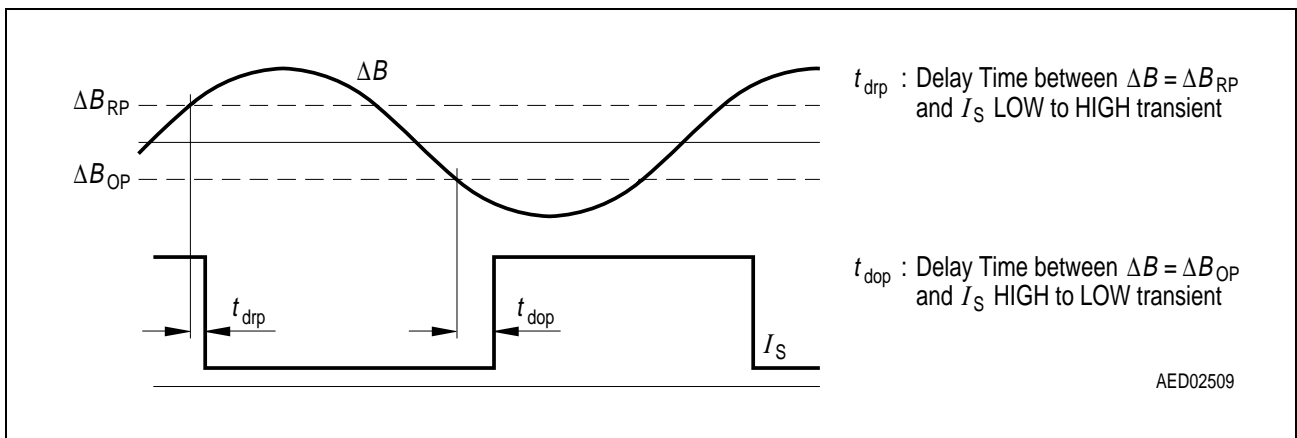

Figure 6 Definition of Delay Times (switching points related to initial measurement @ $\Delta B = 2 \text{ mT}$; $f = 200 \text{ Hz}$)

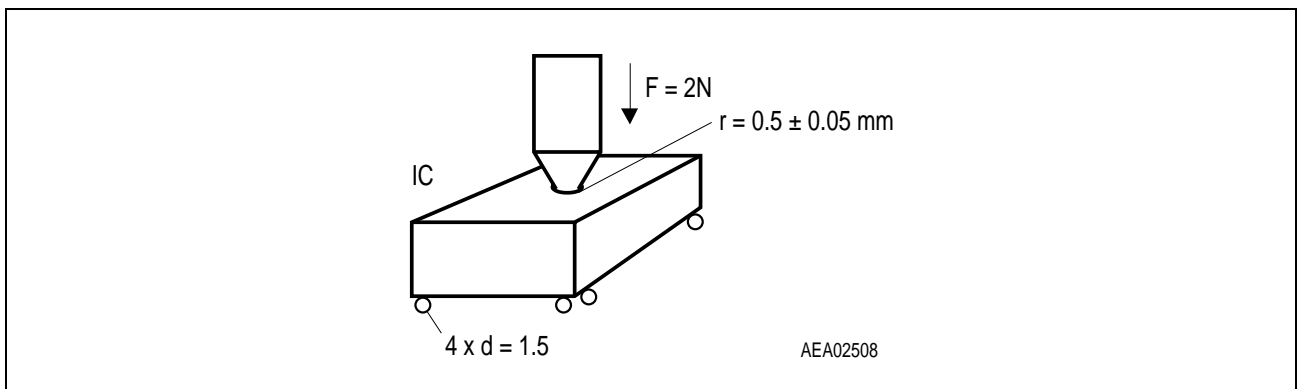

Figure 7 Setup for Piezo Measurements

Application Notes

Two possible applications are shown in **Figure 10** and **Figure 11** (Toothed and Magnet Wheel).

Two-wire application is shown in **Figure 12**.

Gear Tooth Sensing

In the case of ferromagnetic toothed wheel applications the IC has to be biased by the south or north pole of a permanent magnet (e.g. SmCo₅ (Vacuumschmelze VX170) with the dimensions 8 mm × 5 mm × 3 mm) which should cover both Hall probes.

The maximum air gap depends on:

- the magnetic field strength (magnet used; pre-induction) and
- the tooth wheel that is used (dimensions, material, etc.; resulting differential field).

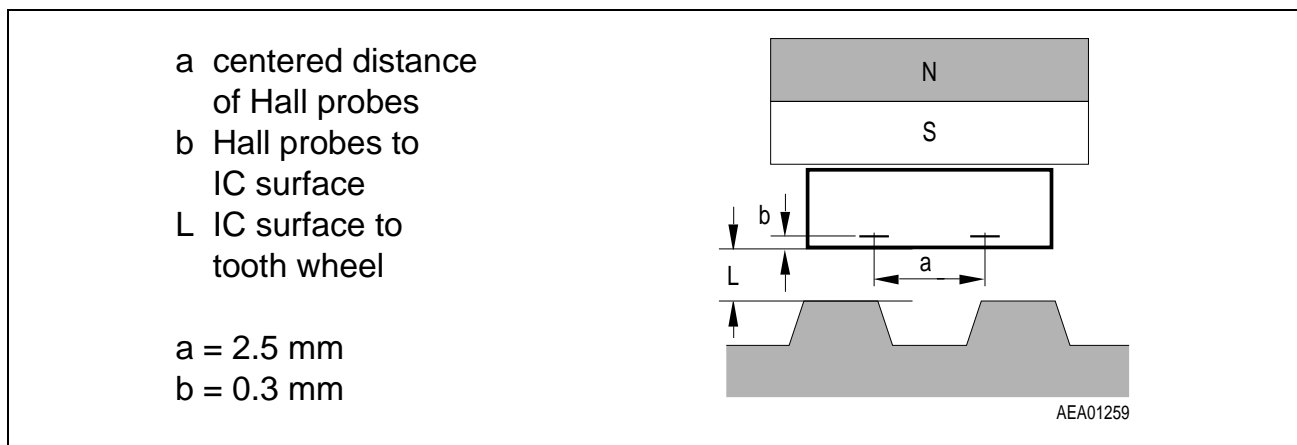

Figure 8 Sensor Spacing

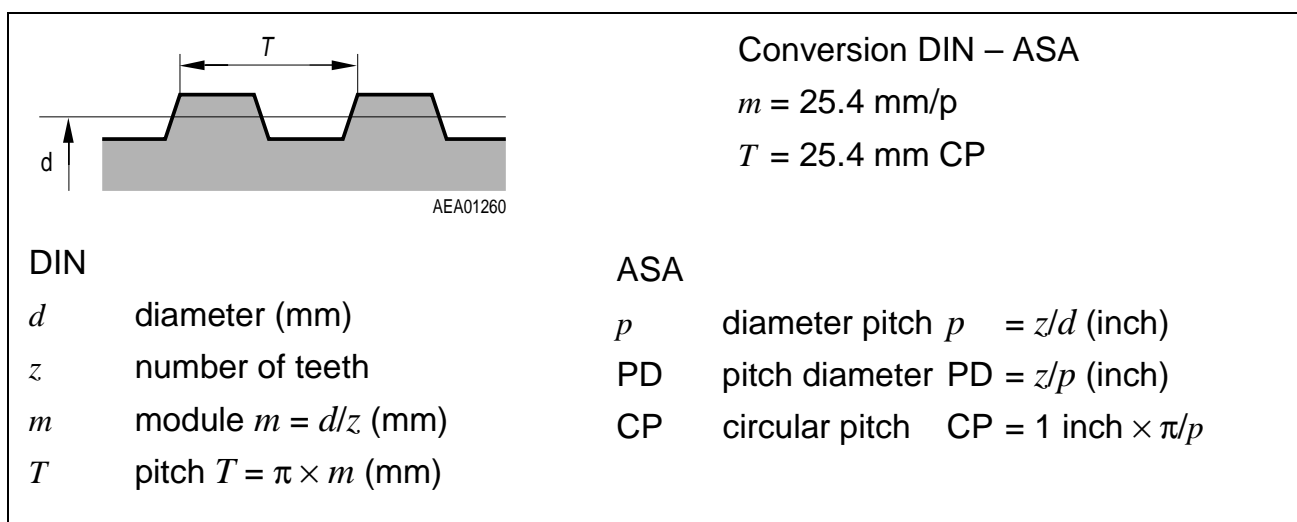

Figure 9 Tooth Wheel Dimensions

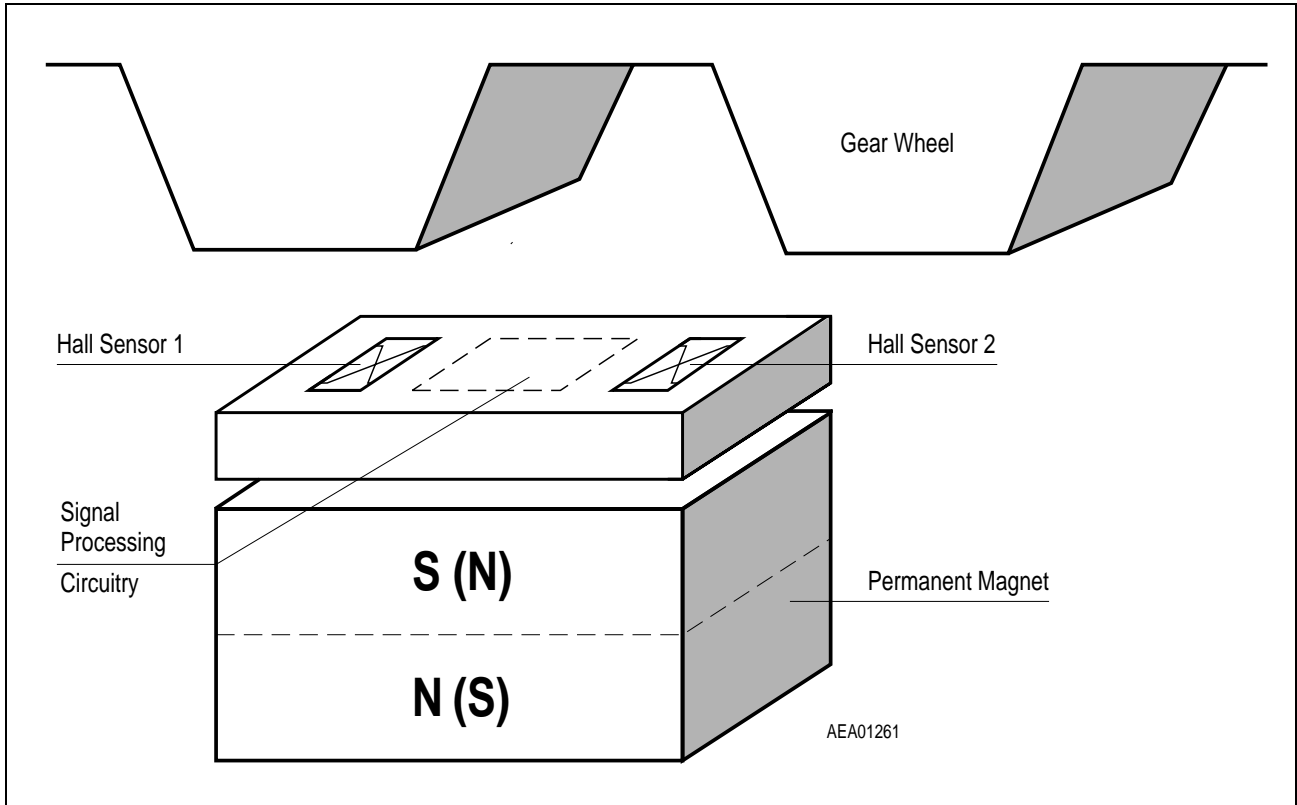

Figure 10 TLE 4923, with Ferromagnetic Toothed Wheel

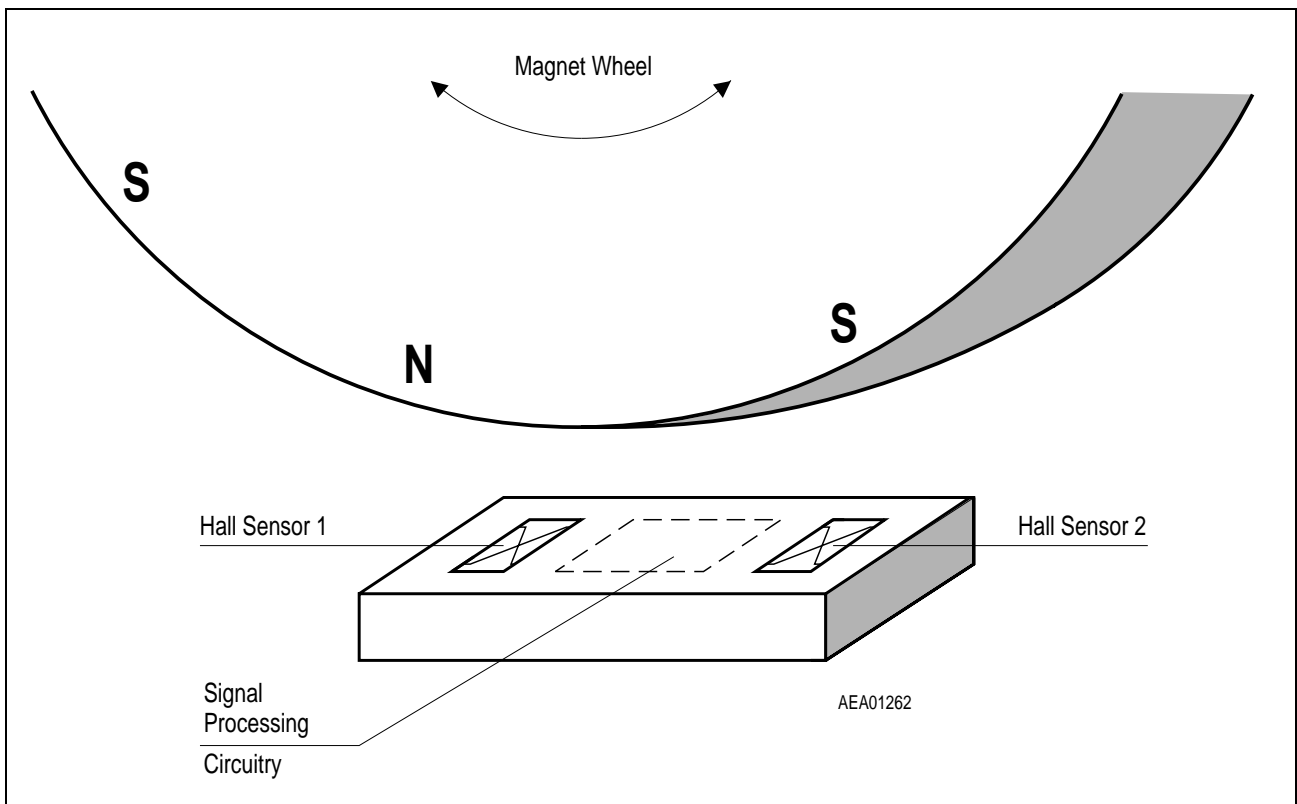

Figure 11 TLE 4923, with Magnet Wheel

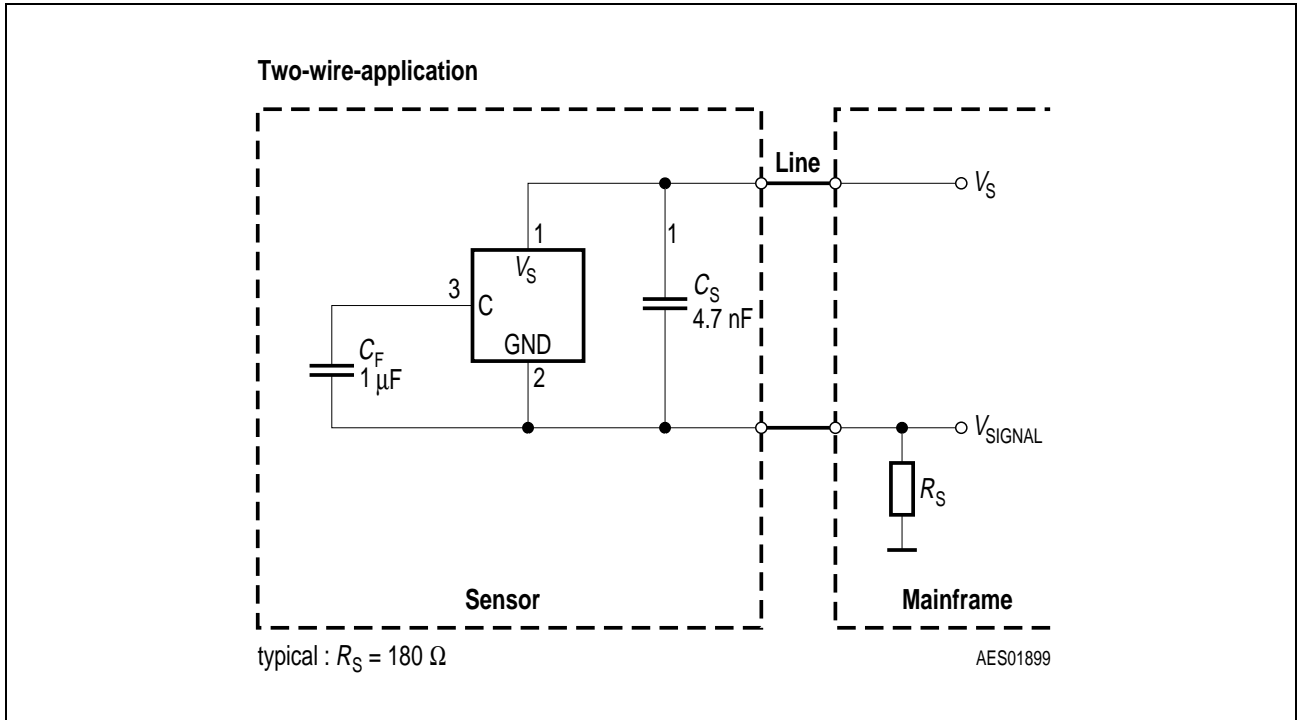

Figure 12 Application Circuit

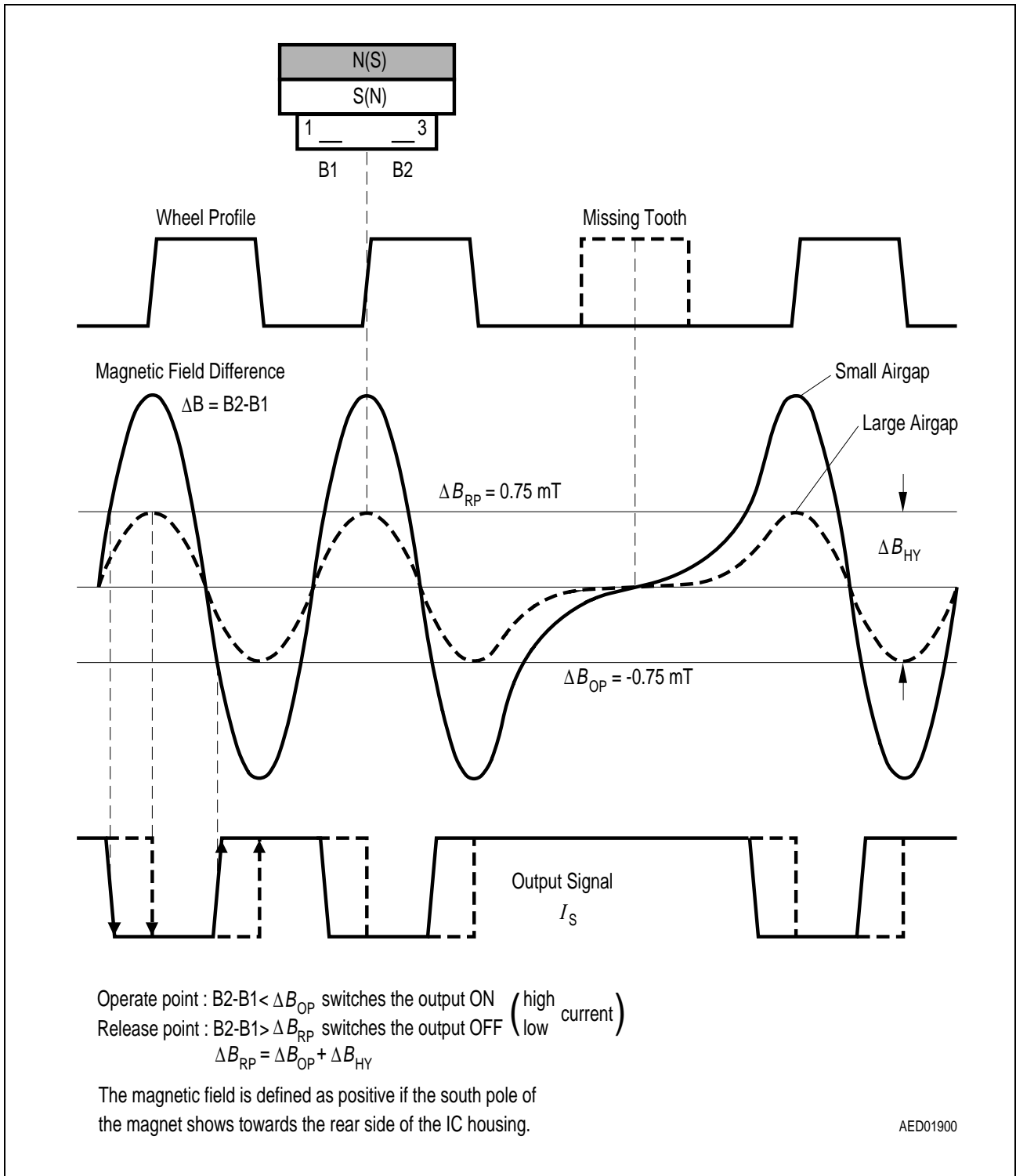
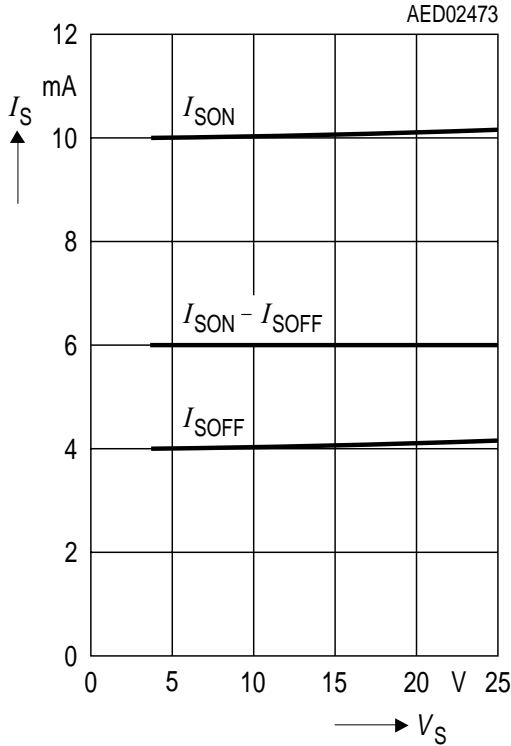

Figure 13 System Operation

If not otherwise specified, all curves reflect typical values at $T_j = 25\text{ °C}$ and $V_S = 12\text{ V}$.

Supply Current and Supply Current Difference versus Supply Voltage



Minimum Switching Field versus Frequency

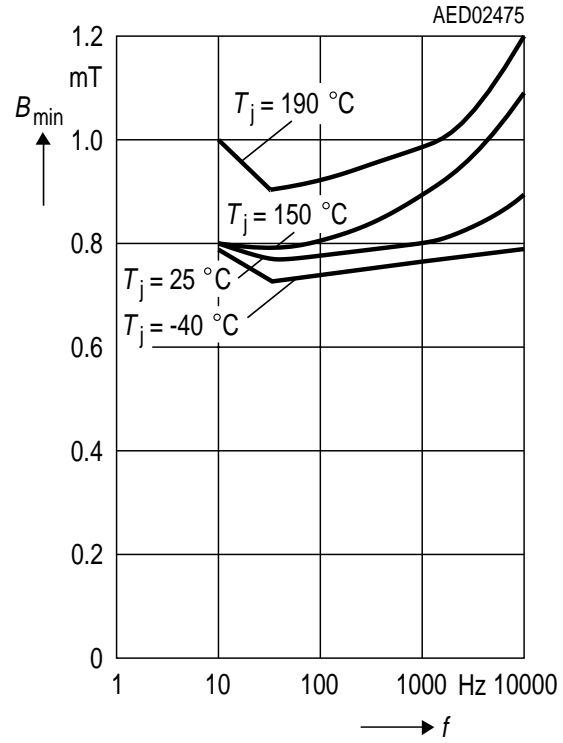

Supply Current and Supply Current Difference versus Temperature

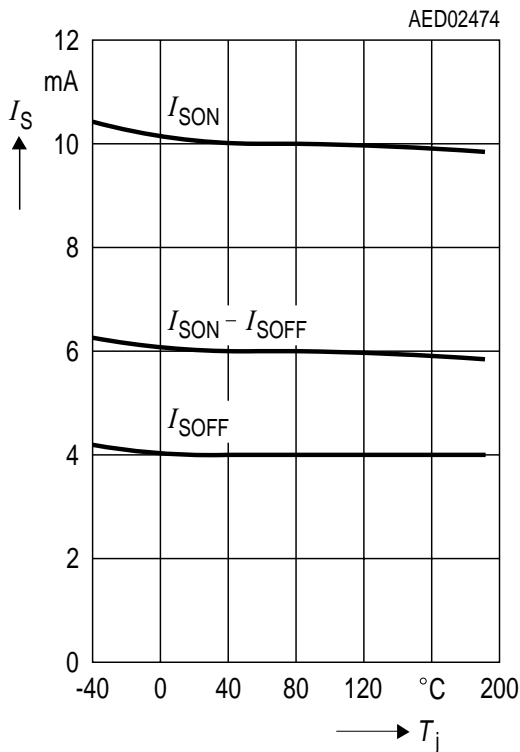

Mean Value of Switching Induction

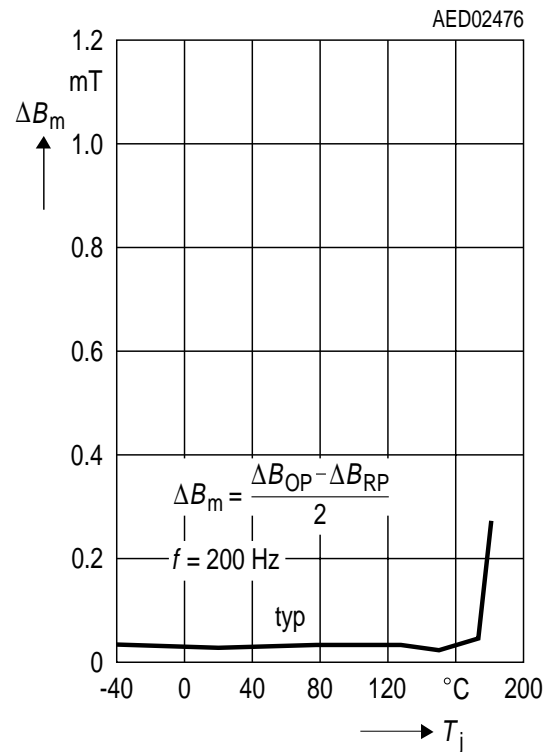

Hysteresis versus Temperature

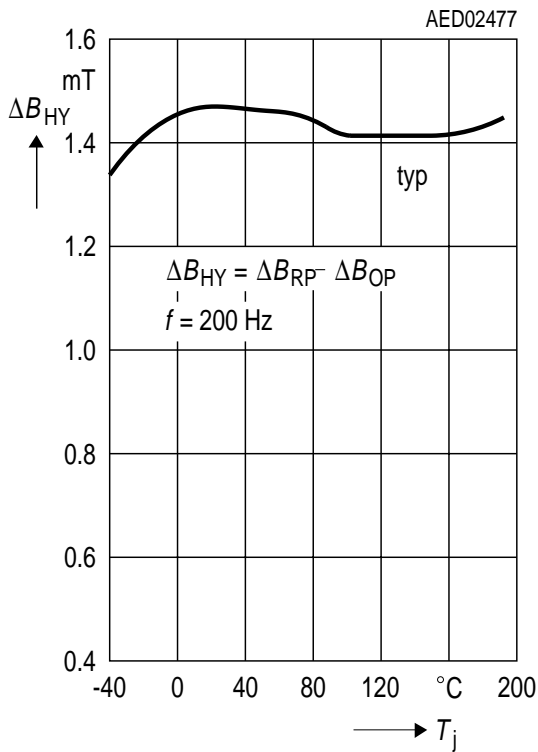

Delay Time¹⁾ versus Temperature

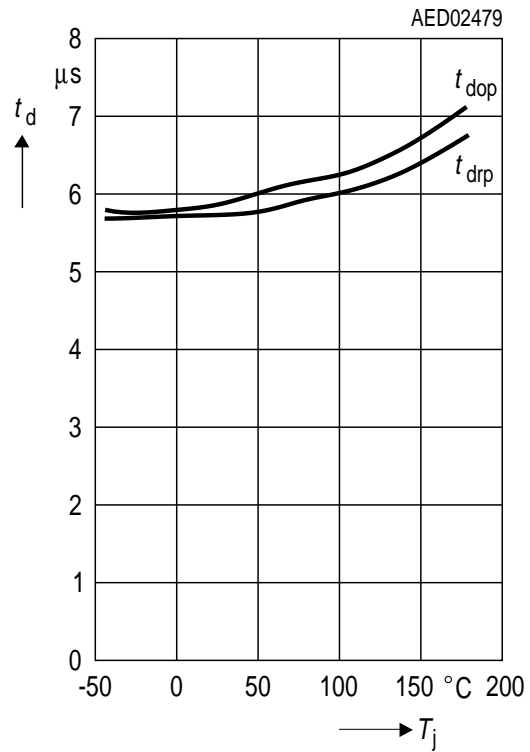

Delay Time¹⁾ versus Differential Field

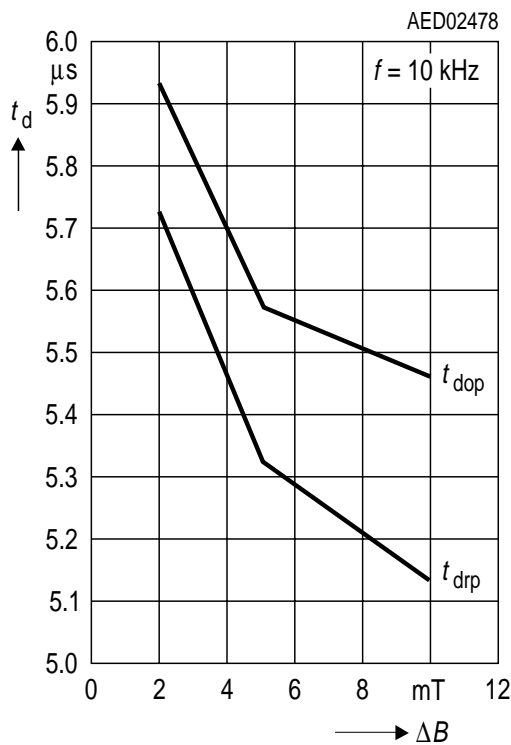

Rise and Fall Time versus Temperature

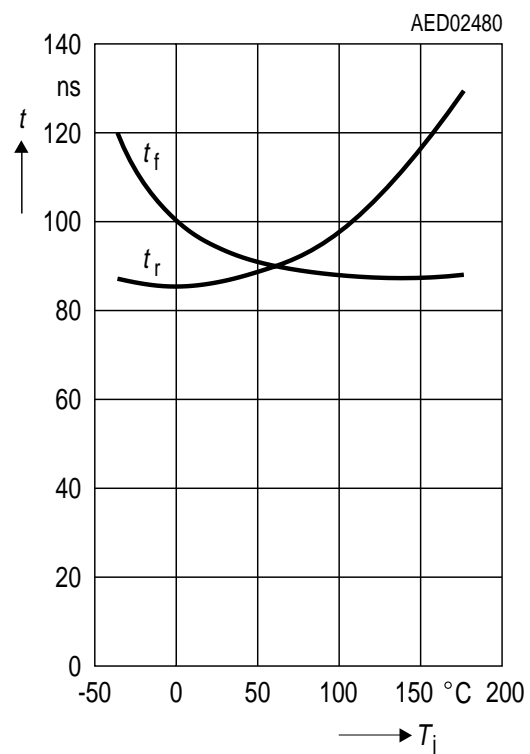

¹⁾ Switching points related to initial measurement
@ $\Delta B = 2 \text{ mT}$, $f = 200 \text{ Hz}$

Capacitor Voltage versus Temperature

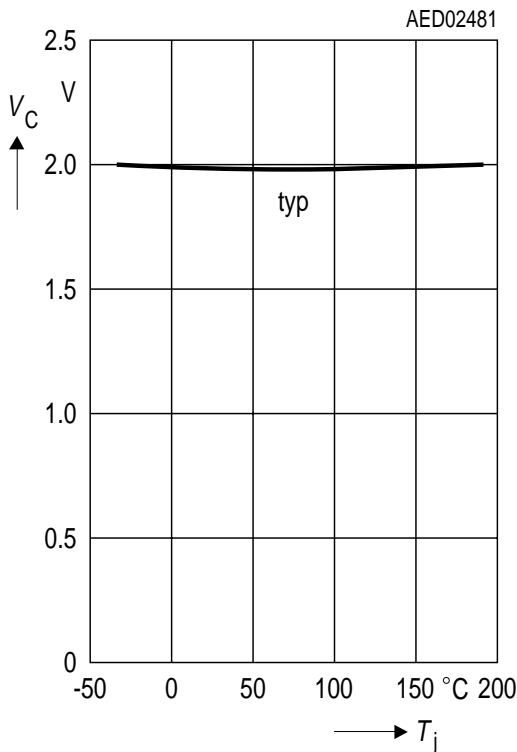

Filter Input Resistance versus Temperature

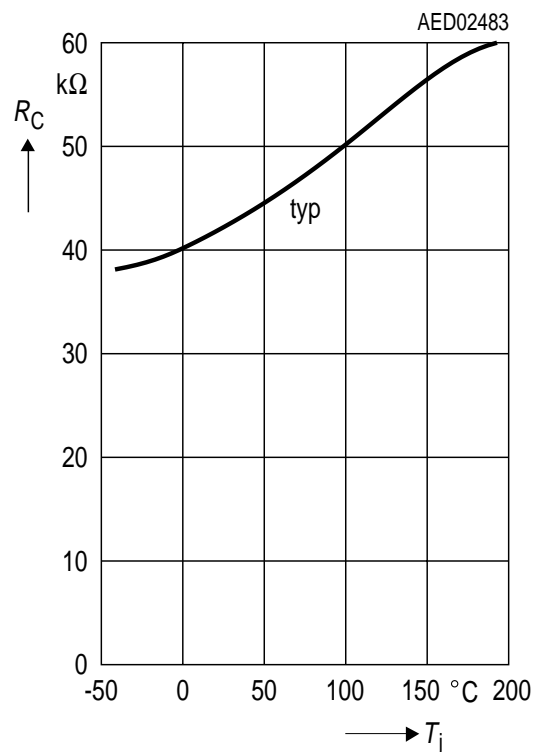

Filter Sensitivity versus Temperature

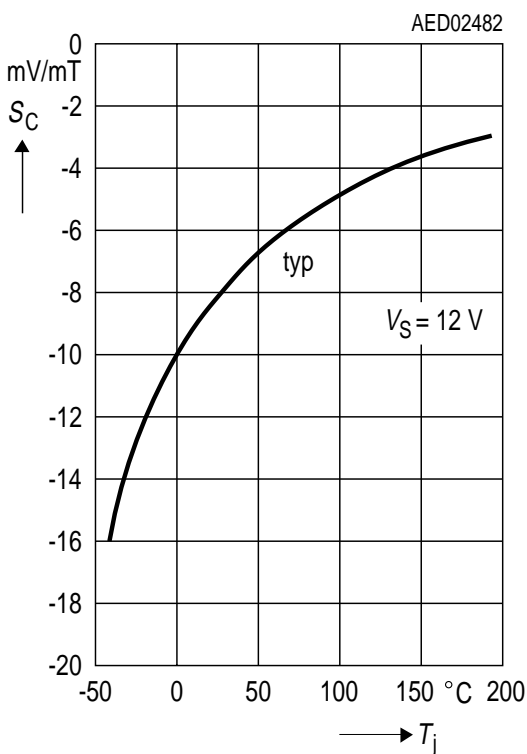

Delay Time t_{pon} for Power ON versus Temperature

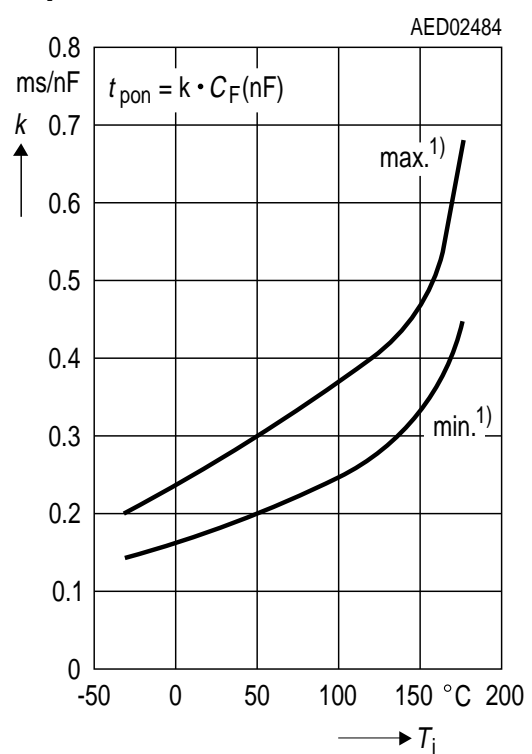

¹⁾ Calculated values for minimum and maximum filter resistance, C_F at room temperature.

Threshold Shift versus Filter Leakage

