

**RED****TOSHIBA T-1¾ InGaAlP Ultra Bright LED**

# TLSE180P

## Product Features -

- InGaAlP Technology
- T-1¾ (5 mm) Package
- High Intensity Red Light ( $\lambda_p = 623 \text{ nm}$ ) Emission
- Water Clear Lens
- Narrow Radiation Pattern

## MAXIMUM RATINGS ( $T_a = 25^\circ\text{C}$ )

CHARACTERISTIC	SYMBOL	RATING	UNIT
Forward Current	$I_F$	50	mA
Reverse Voltage	$V_R$	4	V
Power Dissipation	$P_D$	120	mW
Operating Temperature	$T_{opr}$	-30 ~ 85	$^\circ\text{C}$
Storage Temperature	$T_{stg}$	-40 ~ 120	$^\circ\text{C}$

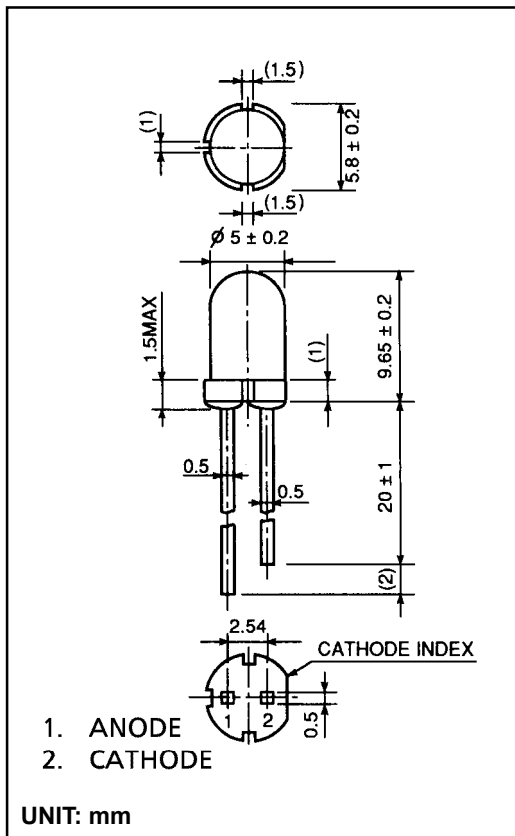

## OPTO-ELECTRICAL CHARACTERISTICS ( $T_a = 25^\circ\text{C}$ )

CHARACTERISTIC	SYMBOL	TEST CONDITION	MIN.	TYP.	MAX.	UNIT
Forward Voltage	$V_F$	$I_F = 20\text{mA}$	—	1.95	2.4	V
Reverse Current	$I_R$	$V_R = 4\text{V}$	—	—	50	$\mu\text{A}$
Luminous Intensity	$I_V$	$I_F = 20\text{mA}$	1530	3500	—	mcd
Viewing Angle	$2\theta_{1/2}$	—	—	8	—	$^\circ$
Peak Wavelength	$\lambda_p$	$I_F = 20\text{mA}$	—	623	—	nm
Dominant Wavelength	$\lambda_d$	$I_F = 20\text{mA}$	—	613	—	nm
Spectral Line Half Width	$\Delta\lambda$	$I_F = 20\text{mA}$	—	15	—	nm

\* Luminous Ranks: (T : 1800-3600mcd), (U : 3200-6400mcd), (V : 5600-11200mcd) Upper and lower limit tolerance  $\pm 15\%$   
Available in Two Bin Combinations: (TU), (UV)

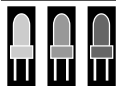

**marktech**  
**optoelectronics**

120 Broadway • Menands, New York 12204

Toll Free: (800) 98-4LEDS • Fax: (518) 432-7454

For up-to-date product info visit our web site at [www.marktechopto.com](http://www.marktechopto.com)

All specifications subject to change.

## TLSE180P Graphs -

