

5-CHANNEL BTL DRIVER FOR DVD PLAYER

DESCRIPTION

The UTC **UA8868** is a five-channel BTL driver IC for driving the motors and actuators such as used in DVD player and CD-ROM.

FEATURES

- * Built-in 5 channel drivers:
 - Dual actuator drivers
 - Sled motor driver
 - Spindle driver
 - Tray in-out driver
- * Built-in Two independent comparators
- * Thermal shut down and Mute circuit.

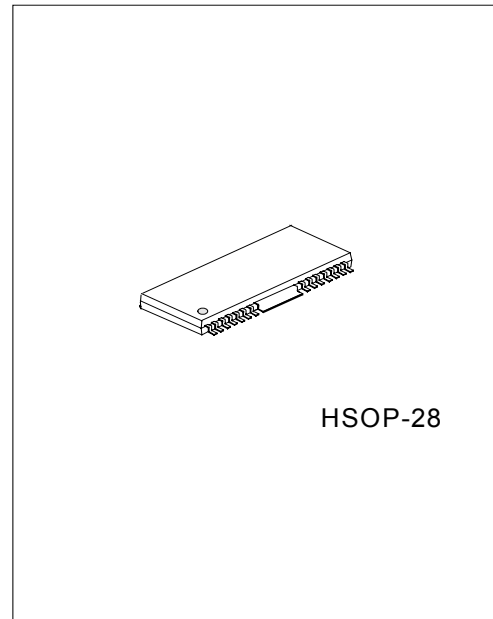

*Pb-free plating product number: UA8868L

BLOCK DIAGRAM

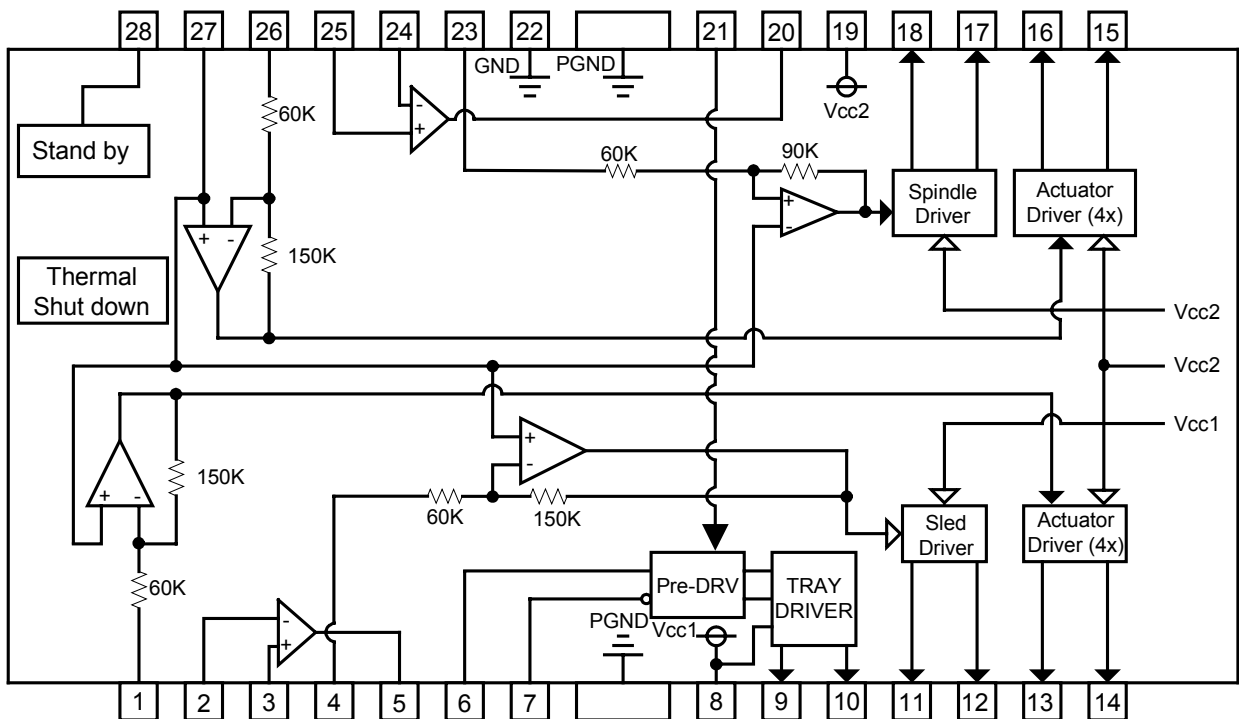

PIN DESCRIPTION

PIN NO	PIN NAME	FUNCTION
1	V _{INFC}	Input for focus driver
2	OP2IN-	Comparator 2 input (-)
3	OP2IN+	Comparator 2 input (+)
4	V _{INSL+}	OPAMP input (+) for the sled driver
5	OP2OUT	Comparator 2 output
6	FWD	Tray driver forward input
7	REV	Tray driver reverse input
8	V _{CC1}	Vcc for pre-drive block and power block of sled and tray
9	V _{OTR-}	Tray driver output (-)
10	V _{OTR+}	Tray driver output (+)
11	V _{OSL-}	Sled driver output (-)
12	V _{OSL+}	Sled driver output (+)
13	V _{OFC-}	Focus driver output (-)
14	V _{OFC+}	Focus driver output (+)
15	V _{OTK+}	Tracking driver output (+)
16	V _{OTK-}	Tracking driver output (-)
17	V _{OLD+}	Spindle driver output (+)
18	V _{OLD-}	Spindle driver output (-)
19	V _{CC2}	Vcc for power block of spindle, tracking and focus
20	OP1OUT	Comparator 1 output
21	V _{CTL}	Speed control input of tray driver
22	GND	Ground
23	V _{INLD}	Input for spindle driver
24	OP1IN-	Comparator 1 input (-)
25	OP1IN+	Comparator 1 input (+)
26	V _{INTK}	Input for tracking driver
27	BIAS	Input for reference voltage
28	MUTE	Input for mute control

Notes: Pin Name of + and – (output of drivers) means polarity to input pin. (For example, if voltage of pin1 is high, pin14 is high.)

ABSOLUTE MAXIMUM RATINGS

(Ta=25)

PARAMETER	SYMBOL	RATINGS	UNIT
Supply Voltage	V _{CC1}	13.5	V
	V _{CC2}		
Power Dissipation	P _D	*1.7	w
Operating Temperature Range	T _{opr}	0 ~ +70	
Storage Temperature Range	T _{stg}	** -40 ~ +150	

*When mounted on a 70mm ×70mm ×1.6mm glass epoxy board.

*Reduced by 13.6mW for each increase in Ta of 1 over 25

**Should not exceed Pd or ASO and T_j=150 values

GUARANTEED OPERATING CONDITIONS

(Ta=25)

PARAMETER	SYMBOL	RATINGS	UNIT
Power Supply Voltage	V _{cc1}	4.3 ~ 13.2	V
	V _{cc2}	4.3 ~ V _{cc1}	V

ELECTRICAL CHARACTERISTICS(Ta=25 , V_{cc1}=12V, V_{cc2}=5V, BIAS=2.5V, R_L=8Ω/10Ω/45Ω)

PARAMETER	SYMBOL	TEST CONDITONS	MIN	TYP	MAX	UNIT
Quiescent Current	I _{cc}			30		mA
Voltage For Mute ON	V _{ston}		0		0.5	V
Voltage For Mute OFF	V _{stoff}		2.0		5	V
Actuator Drivers						
Output Offset Voltage	V _{oo}				±50	mV
Maximum Output Voltage	V _{om}	@10Ω Load	3.6	4.0		V
Voltage Gain	G _v	V _{IN} =BIAS+0.2V _{pp} ac @1KHz		20		dB
Sled Motor Driver						
Output Offset Voltage	V _{oofsl}				±100	mV
Maximum Output Voltage	V _{omsl}	@ 8Ω Load	7.5	9.0		V
Closed Loop Voltage Gain	G _{vsl}	V _{IN} =BIAS+0.2V _{pp} ac @1KH	18	20	22	dB
Spindle Motor Driver						
Output Offset Voltage	V _{oofld}				±50	mV
Maximum Output Voltage	V _{omax}	@ 8Ω Load	3.6	4.0		V
Voltage Gain	G _{vld}	V _{IN} =BIAS+0.2V _{pp} ac @1KHz	13.3	15.5	17.5	dB
Gain Error By Polarity	ΔG _{vld}	V _{IN} =BIAS+0.2V _{pp} ac @1KHz	0	1	2	dB
Tray Motor Driver						
Output Saturation Voltage 1	V _{SAT1}	Upper+Lower saturation, I _L =200mA	0.7	1.1	1.5	V
Output Saturation Voltage Between F&R	ΔV _{SAT1}	Output saturation voltage 1 between FWD and REV			0.1	V
Output Saturation Voltage 2	V _{SAT2}	Upper+Lower saturation, I _L =500mA	1.0	1.55	2.2	V
Output Adjustable Gain On "H" Side Voltage	V _{VtrH}	"H" Side output for input (V _{TCL})	7.4	9.2	11	dB
Tray Motor Driver Input Logic						
High Level Input Voltage	V _{IH}		1.5		V _{CC}	V
Low Level Input Voltage	V _{IL}		-0.3		0.5	V
High Level Input Current	I _{IH}	V _{FWD} =V _{REV} =5V		180	270	μA
Comparator						
Input Offset Voltage	V _{oofc}				±2.0	mV
Input Common-mode Voltage Range	V _{CMC}		0		V _{CC1} ±1.5	V
Voltage Gain	G _{VC}	R _L 15kΩ	50			V/mV
Output Sink Current	I _{osc}	V _{out} < 1.5V		6.0		mA
Saturation Voltage	V _{sc}	I _{osc} 4mA			400	mV

* This device is not designed for protection against radioactive rays.

POWER DISSIPATION CURVE

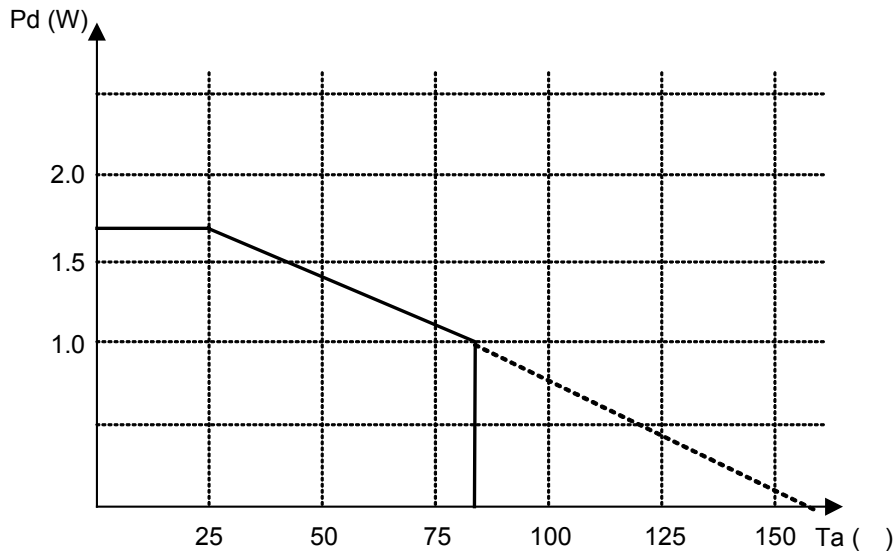

*70mm 70mm 1.6mm glass epoxy board.
 *Debating in done at 17.6mW / for operating above Ta=25

OPERATING NOTES

- (1) The built-in thermal shutdown circuit will shutdown the output current when the chip junction temperature reaches 150 (typ.).The hysteresis is set to 25 (typ.), so the circuit will restart up if the chip temperature falled down below 125 (typ.)
- (2) If mute pin is setted to under 0.5V or NC, output current is off (except for spindle driver). Mute pin voltage should be higher than 2.0V for normal application.
- (3) Bias pin (pin 27) should be set to more than 1.2V for proper working. If the bias pin voltage is fall below 0.9V (typ.), the output current will be muted.
- (4) Insert the bypass capacitor (~ 0.1 μ F) between Vcc pin and GND pin as close as possible.
- (5) when Vcc1 voltage drop to below 3.8V, functions are muted. The function will return to work when Vcc1 increase to over a hysteresis of 03.V (typ.)
- (6) Heat dissipation fins are connected to the GND of the chip. Make sure to connect them to power supply GND.

Tray driver logic input:

FWD (pin6)	REV (pin7)	VOL+ (pin10)	VOL- (pin9)	Function
L	L	OPEN	OPEN	Open mode
L	H	L	H	Reverse mode
H	L	H	L	Forward mode
H	H	L	L	Brake mode

Input circuit of pin6 and pin7 is designed to avoid simultaneous activation of upper and lower output transistors.; however, in order to improve reliability, apply motor forward/reverse input once each input with time interval be longer than 10msec.

“H” Side output voltage (VOL+, VOL-) varies depending on output control terminal for tray (pin21),which is set about three times of VTCL(pin21) (9.2dB Typ.). And, “L” Side output voltage is equal to output saturation voltage for working mode. . And the “H” side and “L” side output voltage are both equal to VCC/2 when in open mode and brake mode.

APPLICATION CIRCUIT

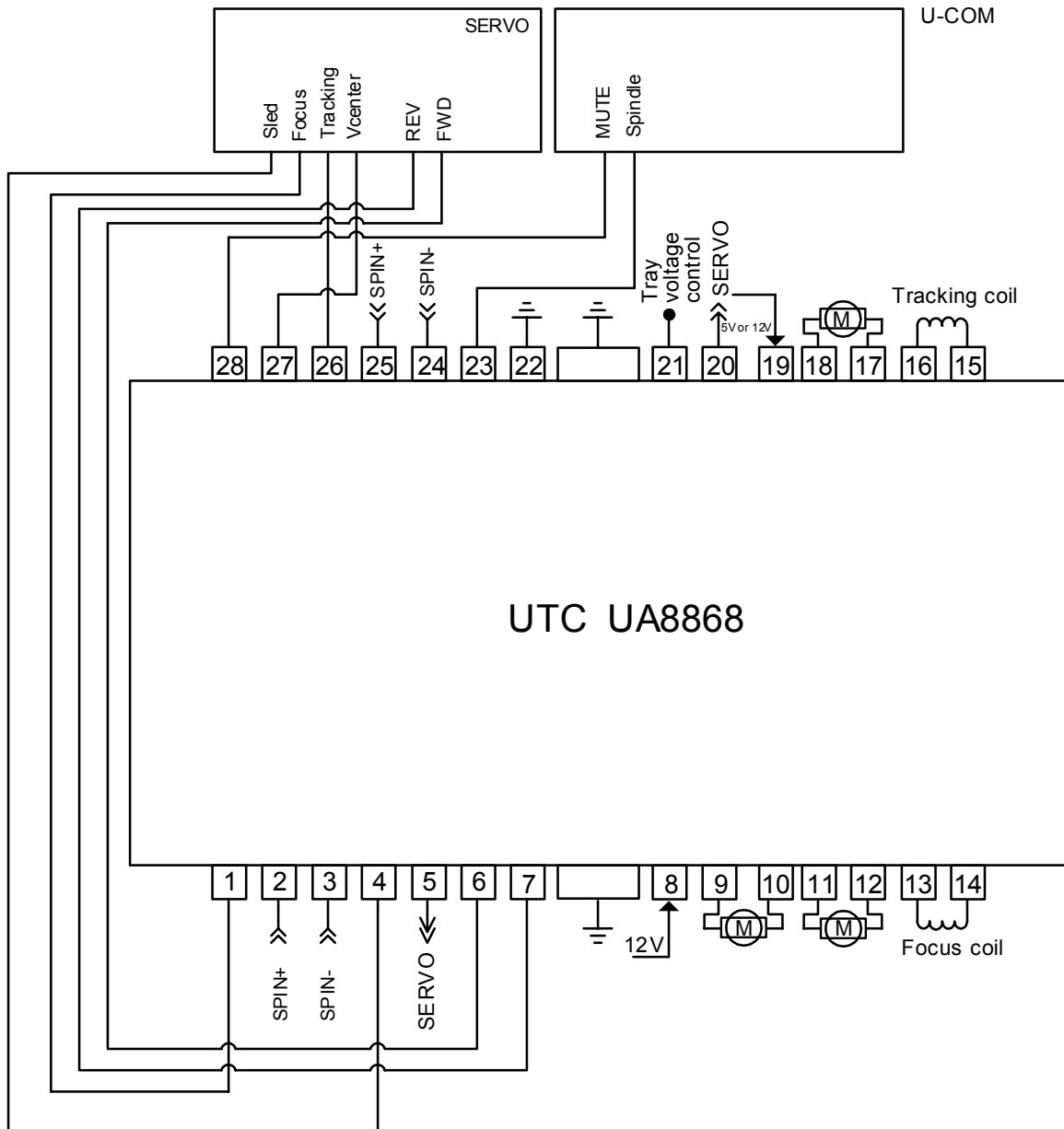

TESTING CIRCUIT

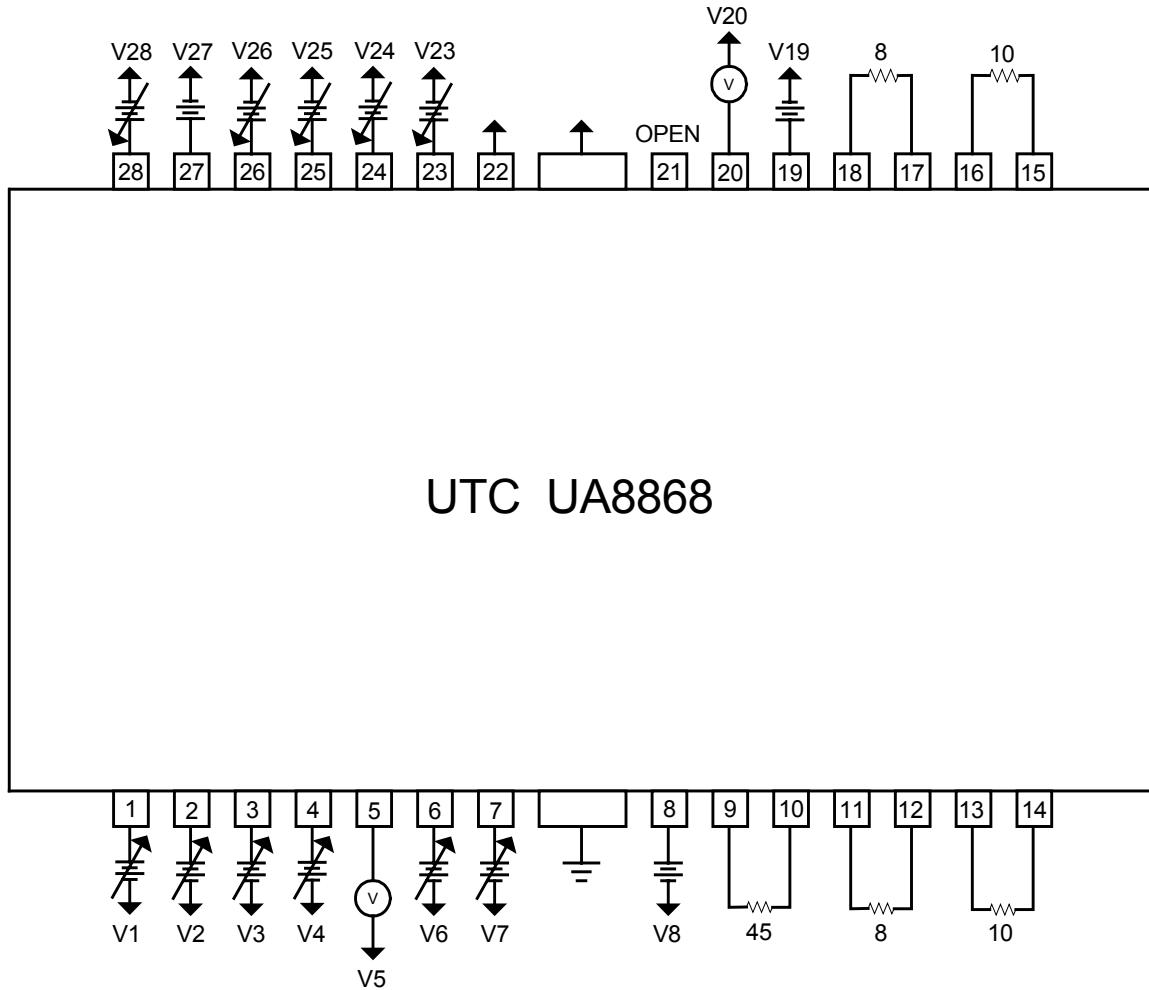

UTC assumes no responsibility for equipment failures that result from using products at values that exceed, even momentarily, rated values (such as maximum ratings, operating condition ranges, or other parameters) listed in products specifications of any and all UTC products described or contained herein. UTC products are not designed for use in life support appliances, devices or systems where malfunction of these products can be reasonably expected to result in personal injury. Reproduction in whole or in part is prohibited without the prior written consent of the copyright owner. The information presented in this document does not form part of any quotation or contract, is believed to be accurate and reliable and may be changed without notice.