

Transistors

USP10

VHF/UHF TRANSISTOR

ABSOLUTE MAXIMUM RATINGS ($T_a=25^\circ\text{C}$)

Characteristic	Symbol	Rating	Unit
Collector-Base Voltage	V_{CBO}	30	V
Collector-Emitter Voltage	V_{CEO}	25	V
Emitter-Base Voltage	V_{EBO}	3.0	V
Collector Dissipation ($T_a=25^\circ\text{C}$)	P_C	350	mW
Derate above 25°C		2.8	mW/ $^\circ\text{C}$
Collector Dissipation ($T_c=25^\circ\text{C}$)	P_C	1.0	W
Derate above 25°C		8.0	mW/ $^\circ\text{C}$
Junction Temperature	T_j	150	$^\circ\text{C}$
Storage Temperature	T_{stg}	-55~150	$^\circ\text{C}$
Thermal Resistance, Junction to Case	$R_{th(j-c)}$	125	$^\circ\text{C/W}$
Thermal Resistance, Junction to Ambient	$R_{th(j-a)}$	357	$^\circ\text{C/W}$

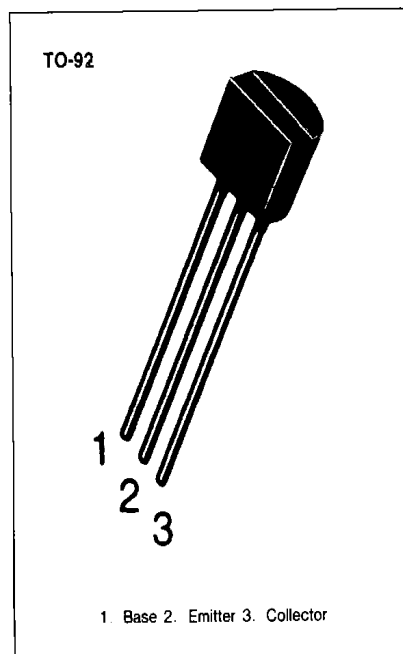

ELECTRICAL CHARACTERISTICS ($T_a=25^\circ\text{C}$)

Characteristic	Symbol	Test Condition	Min	Max	Unit
Collector-Base Breakdown Voltage	BV_{CBO}	$I_C=100\mu\text{A}, I_E=0$	30		V
Collector-Emitter Breakdown Voltage	BV_{CEO}	$I_C=1\text{mA}, I_B=0$	25		V
Emitter-Base Breakdown Voltage	BV_{EBO}	$I_E=10\mu\text{A}, I_C=0$	3.0		V
Collector Cutoff Current	I_{CBO}	$V_{CB}=25\text{V}, I_E=0$		100	nA
Emitter Cutoff Current	I_{EBO}	$V_{EB}=2\text{V}, I_C=0$		100	nA
DC Current Gain	h_{FE}	$V_{CE}=10\text{V}, I_C=4\text{mA}$	60		
Collector Emitter Saturation Voltage	$V_{CE(sat)}$	$I_C=4\text{mA}, I_B=0.4\text{mA}$		0.5	V
Base-Emitter On Voltage	$V_{BE(on)}$	$V_{CE}=10\text{V}, I_C=4\text{mA}$		0.95	V
Current Gain Bandwidth Product	f_T	$V_{CE}=10\text{V}, I_C=4\text{mA}$	650		MHz
Collector Base Capacitance	C_{cb}	$V_{CB}=10\text{V}, I_E=0, f=1\text{MHz}$		0.7	pF
Collector Base Feedback Capacitance	C_{rb}	$V_{CB}=10\text{V}, I_E=0, f=1\text{MHz}$	0.35	0.65	pF
Collector Base Time Constant	$C_c \cdot r_{bb}'$	$V_{CB}=10\text{V}, I_C=4\text{mA}, f=31.8\text{MHz}$		9.0	ps

