

Microsemi Corp.

The diode experts

SANTA ANA, CA

SANTA ANA, CA

SCOTTSDALE, AZ

For more information call:
(602) 941-6300

**USR 931
thru
USR 934**

**WITH CERTIFIED
ZENER VOLTAGE
STABILITY**

DESCRIPTION

This series of Microsemi 400mW Ultra-Stable Reference Diodes offers a **CERTIFIED REFERENCE VOLTAGE STABILITY** as measured over an actual operating period of 1000 hours. Standard stabilities are 10, 20, and 50 PPM/1000 hours. Units having stabilities of less than 5 PPM/1000 hours are available on special request.

Ultra-Stable Certified Reference Diodes, available in standard or radiation hardened construction, can be used in any circuit that requires a stable reference voltage that is insensitive to shock, vibration, or position. Their inherent stability allows them to be used in circuits requiring an extremely high degree of voltage time stability such as those in Digital Voltmeters, Computers, X-Y Recorders, Missile Guidance and Environmental Control Systems, and Portable Reference Standards. Wherever accurate and reliable measurements are to be made, the Microsemi "Ultra-Stable" diode excels as the Standard Reference device.

All devices in this series have been subjected to Microsemi's 1000 hour Stability Test Sequence, consisting of a 1000 hour power age with reference voltage measured once every 168 hours giving a total of 7 individual test points. The stability test is performed at $80^{\circ}\text{C} \pm 0.1^{\circ}\text{C}$.

A Certificate containing the following data is supplied with each diode:

1. The stability test voltage readings.
2. The voltage drift as referenced to "Zero Hour" in both μV and in PPM (Parts-Per-Million).

To certify these diodes to such tight stabilities as 5PPM/1000 hours, every factor of environment, both ambient and electrical is considered and controlled to "Standards Laboratory" accuracy.

Consult factory for TX, TXV or JANS equivalent SCDs.

**9.3 VOLT
ULTRA STABLE
TEMPERATURE
COMPENSATED
ZENER REFERENCE
DIODES**

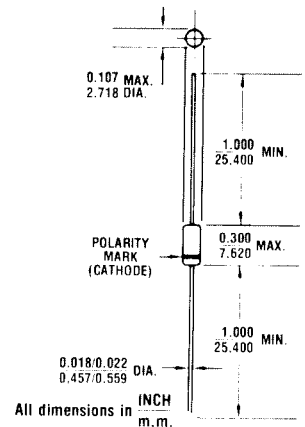

MECHANICAL CHARACTERISTICS

CASE: Hermetically sealed glass case. DO-7.

FINISH: All external surfaces are corrosion resistant and leads solderable.

THERMAL RESISTANCE: $300^{\circ}\text{C}/\text{W}$ (Typical) junction to lead at 0.375-inches from body.

POLARITY: Diode to be operated with the banded end positive with respect to the opposite end.

WEIGHT: 0.2 grams

MOUNTING POSITION: Any.

9.3 VOLT ULTRA-STABLE (T.C.) ZENER REFERENCE DIODES

MAXIMUM RATINGS (See Fig. 6)

Operating Temperature Range:
-65°C to +175°C

Maximum Lead Temperature 1/8 ± 1/32 inch
from case for 8 seconds: 230°C

Maximum DC Power Dissipation at or below
50°C Ambient

Linear Derating: 3.2 mW/°C (See Figure 6)

Maximum Steady State Current (I_{ZM}) at
+150°C: 7.5 mA

MECHANICAL CHARACTERISTICS

Case: Hermetically sealed glass

Dimensions: DO-7 outline

Finish: All external surfaces are corrosion re-
sistant and leads are readily solderable

Polarity: Diode to be operated with the banded
end positive

Weight: 0.2 grams (typical)

Mounting Position: Any

ELECTRICAL CHARACTERISTICS at 25°C, unless otherwise specified.

MICRO TYPE NUMBER	NOMINAL ZENER VOLTAGE ± 5% $V_Z @ I_{ZT}$	ZENER TEST CURRENT ± 0.01 mA I_{ZT}	MAXIMUM ZENER IMPEDANCE $Z_{ZT} @ I_{ZT}$ (NOTE 1)	VOLTAGE TEMPERATURE STABILITY ΔV_{ZT} MAXIMUM (NOTE 2)	TEMPERATURE RANGE	EFFECTIVE TEMPERATURE COEFFICIENT	VOLTAGE TIME STABILITY @ 80°C INITIAL-TO-PEAK ΔV_{ZT} MAXIMUM (NOTE 3)	EFFECTIVE VOLTAGE TIME STABILITY INITIAL-TO- PEAK
	VOLTS	mA	OHMS	mV	°C	%/°C	$\mu V/1000$ HRS.	PPM/1000 HRS.
USR931	9.3	7.5	20	3.4	25 to 100	.0005	465	50
USR932	9.3	7.5	20	3.4	25 to 100	.0005	186	20
USR933	9.3	7.5	20	3.4	25 to 100	.0005	93	10
USR934	9.3	7.5	20	3.4	25 to 100	.0005	46	5

NOTE 1

The zener impedance is derived from the 60 Hz ac voltage which results when an ac current having an rms value equal to 10% of the DC zener current (I_{ZT}) is superimposed on I_{ZT} .

NOTE 2

The maximum allowable change observed over the entire temperature range i.e., the diode voltage will not exceed the specified mV change at any discrete temperature between the established limits.

NOTE 3

When operated at:

$$I_{ZT} = 7.5 \text{ mA} \pm 0.0001 \text{ mA}$$

$$T_A = 80^\circ\text{C} \pm 0.1^\circ\text{C}$$

(See Note 2 Below)

NOTES AND PRECAUTIONS FOR CERTIFIED REFERENCE DIODES

1. DIODE IDENTIFICATION: The diodes are shipped attached to their certification papers and each diode is individually packaged with the diode identification on the package. Identification includes MICRO type number and a diode serial number consisting of 7 digits showing the lot number and diode number, which provide traceability to factory records.

2. PRECAUTIONS: The normal precautions must be taken when soldering as with any semiconductor device, such as a thermal shunt between the soldering iron and the diode body. "Mechanical" rather than solder mounting is preferred for optimum performance. Mounting the diode inside a large thermal mass such as aluminum, copper, brass, or epoxy will reduce thermally induced voltage fluctuations discernible as low frequency noise in the 0-3 Hz region of the spectrum.

current through the zener is not controlled, the reference voltage will shift due to diode impedance ($\Delta V_Z = \Delta I_Z \times Z_{ZT}$). If the diode's junction temperature is allowed to change, due to a change in ambient or case temperature or due to a power level change, a shift in voltage will occur consistent with the temperature coefficient of the diode. In addition, the device must be physically mounted so as to give the diode a constant thermal resistance, junction-to-ambient. Drafts, circulating oil, and even the minute convection currents produced by a diode in a closed container can cause shifts in reference voltage greater than those that can be attributed to the diode's inherent stability.

The certified stability of a diode is achieved only under steady state, constant temperature conditions. If the diode is operated at conditions other than the certification test conditions, it is recommended that it be operated for a period of 2 to 3 weeks under circuit

operating conditions to achieve rated stability.

A slight derating of voltage-time stability (ΔV_{ZT}) may be experienced if the diode is operated outside the "stable-area" defined in Figure 6.

Temperature coefficients much lower than specified can be attained by operating the diode at "0" TC crossover current (the current at which the TC goes from positive to negative or vice-versa), however, a new "equilibrium" must be reached before full stability will be attained.

3. MICROSEMI TEST METHOD: Microsemi uses a potentiometric method of zener voltage measurement on certified reference diodes. Zener voltage is measured to seven digits (1 microvolt

resolution). Voltage calibration is directly traceable to the National Bureau of Standards. Oil bath temperature is controlled to better than 0.1°C , and current is constant and repeatable to better than $\pm 0.1 \mu\text{A}$. Test clips are designed for the four-terminal method of measurement (separate voltage and current connections) to eliminate errors caused by resistance. The diodes are thermally shielded by an aluminum thermal filter to reduce thermally created error causing voltage fluctuations.

4. 1000 HOUR STABILITY TEST SEQUENCE: Voltage is measured seven times during the test with the last six measurements referenced to the first. The measurements are taken 168 hours apart, giving a total test time of 1008 hours.

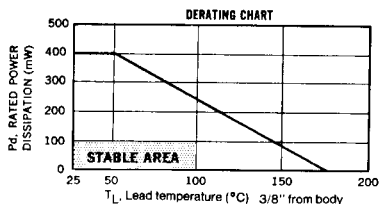
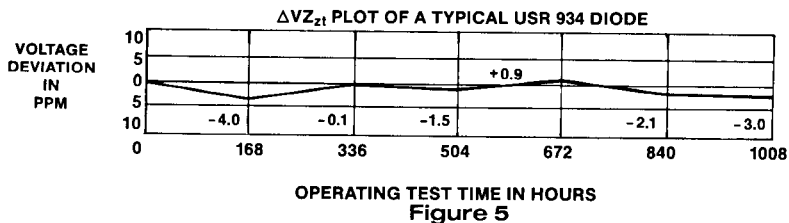
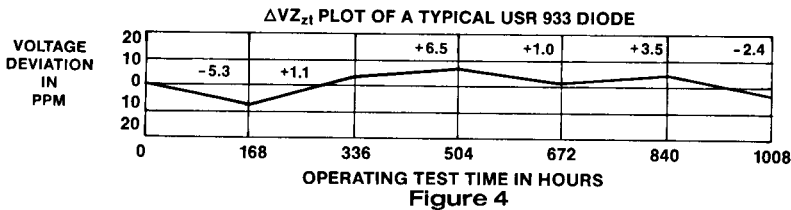
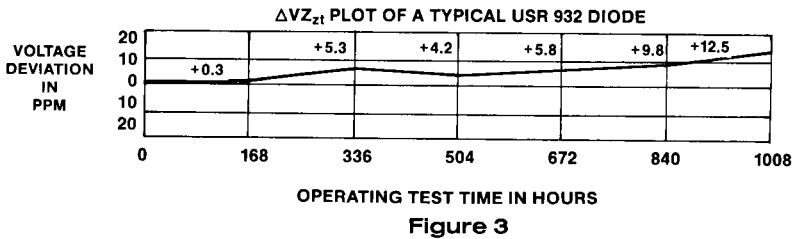
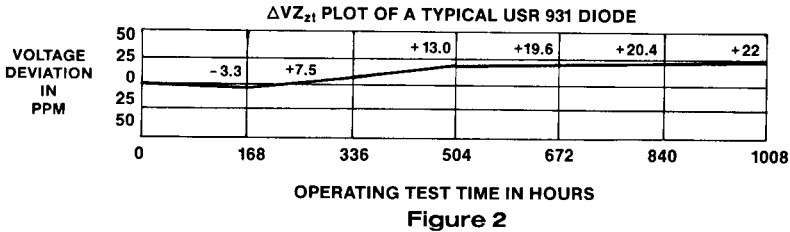

THE "STABLE AREA" IS DEFINED AS THE AREA IN WHICH THE MAXIMUM TIME STABILITY (ΔV_a) IS ATTAINABLE.

A SLIGHT DERATING IN THE TIME STABILITY MAY BE EXPECTED IF THE DIODE IS OPERATED OUTSIDE THIS AREA.

Figure 6

9.3 VOLT ULTRA-STABLE (T.C.) ZENER REFERENCE DIODES

1000 HOUR STABILITY TEST SEQUENCE

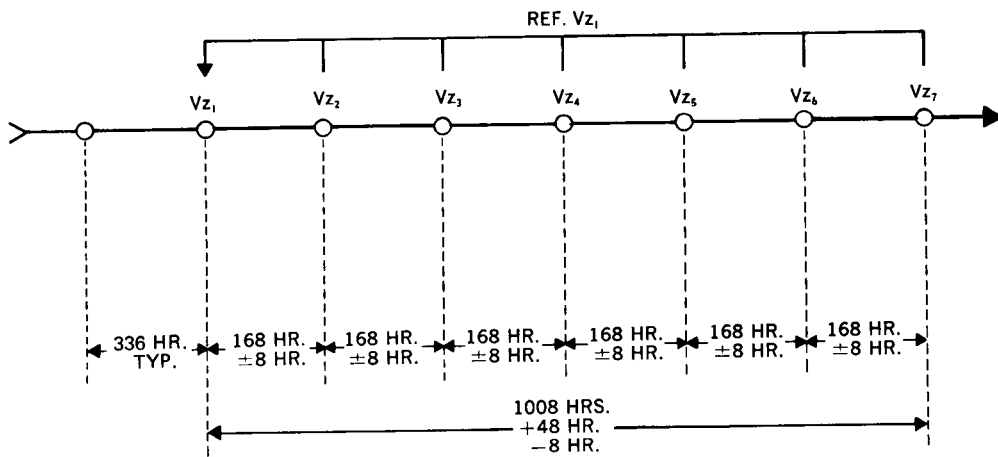

Notes:

Test Temperature $80^{\circ}\text{C} \pm 0.1^{\circ}\text{C}$

Test Current 7.5 mA, with a constancy and repeatability of ± 0.1 microamp.

The first 336 hours of operation is a stabilization period. The stability of a diode is measured by the worst voltage difference (ΔV_z) referenced to V_{z1} .