

**Decoder For Remote Controller  
With Five Functions**

**DESCRIPTION**

The chip can be used with the encoder RCT02 to provide a complete control functions to the remote-controlled toy. The RCR02 has five output pins corresponding with the five function actions i.e, forward, backward, rightward, leftward and turbo. The received signals are amplified by the three-stage amplifier, and then the appropriate amplified signals are sampled, fault-tolerantly checked and decoded to control the actions of the remote-controlled toy.

There is an internal oscillator in the RCR02. By adding an external resistor conveniently, the oscillator will be constructed. The oscillator frequency can be adjusted by the external resistor. The relative error between the frequencies of the two on chip oscillators in the RCT02 and RCR02 must be less than  $\pm 25\%$ .

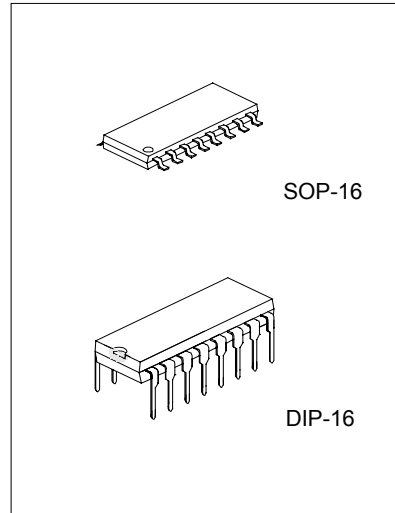

**FEATURES**

- \*Five output pins for control functions
- \*Operating power-supply voltage range: 2.5 to 5.0V
- \*On-chip reversing amplifiers
- \*On-chip oscillator with an external resistor
- \*Low operating current
- \*Few external components needed

**LOGIC BLOCK DIAGRAM**

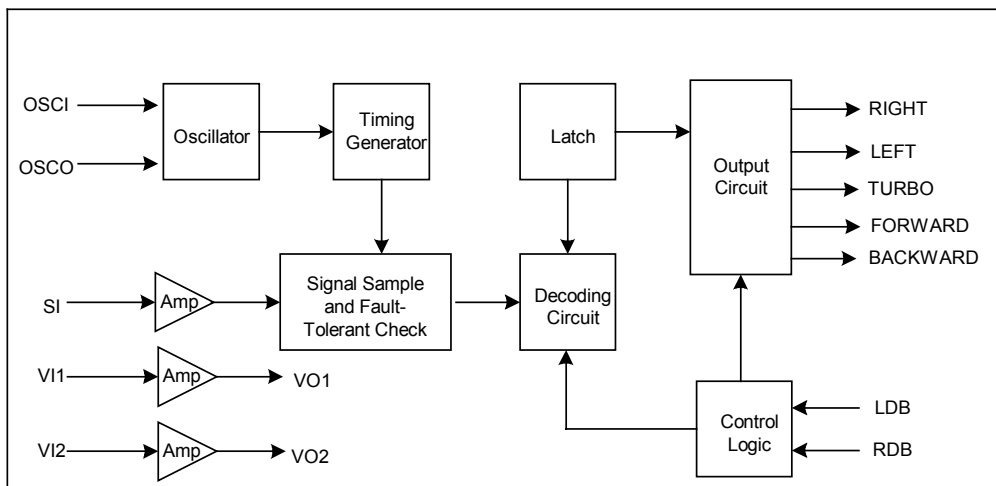

PRODUCT PIN CONFIGURATION AND DESCRIPTION

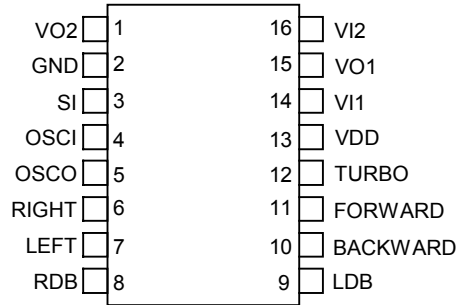

Pin No.	Pin Name	Description
1	VO2	Output pin for the amplifier 2
2	GND	Negative power supply
3	SI	Input pin of the encoding signal
4	OSCI	Oscillator input pin
5	OSCO	Oscillator output pin
6	RIGHT	Rightward output pin
7	LEFT	Leftward output pin
8	RDB	Rightward function disable, if this pin is connected to GND
9	LDB	Leftward function disable, if this pin is connected to GND
10	BACKWARD	Backward output pin
11	FORWARD	Forward output pin
12	TURBO	Turbo output pin
13	VDD	Positive power supply
14	VI1	Input pin for the amplifier 1
15	VO1	Output pin for the amplifier 1
16	VI2	Input pin for the amplifier 2

ABSOLUTE MAXIMUM RATINGS

PARAMETER	SYMBOL	VALUE	UNIT
DC Input Voltage	$V_{IN}$	-0.5 ~ +5.5	V
Supply Voltage to Ground Potential(Inputs &VDD Only)		-0.5 ~ +5.5	V
Supply Voltage to Ground Potential(Outputs &D/O Only)		-0.5 ~ +5.5	V
DC Output Current	$I_o$	20	mA
Power Dissipation	$P_D$	500	mW
Ambient Temperature With Power Applied	$T_A$	-10 ~ +40	°C
Storage Temperature	$T_{STG}$	-25 ~ +85	°C

DC ELECTRICAL CHARACTERISTICS(Over the operating rating, TA= -10°C~ +40°C, VDD=4.0V±10%)

PARAMETER	SYMBOL	TEST CONDITIONS	MIN	TYP	MAX	UNITS
Operating Voltage	VDD		2.5	4.0	5.0	V
Supply Current	IDD	*			3.0	mA
Input Current	IIN	For RDB and LDB pins			60	μA
Input Low Voltage	VIL	For RDB and LDB pins			0.5	V
Input High Voltage	VIH	For RDB and LDB pins	3.5			V
Output High Voltage	VOH	IOUT=400μA	3.5			V
Output High Current	IOH	VOUT=1.4V	-1.5			mA
Output Low Voltage	VOL	IOUT=1.0mA			0.5	V
Output Low Current	IOL	VOUT=0.5V	1.0			mA

Note\*:Output unloads; 2.2MΩ feedback resistors for the two reversing amplifiers; 200KΩ external resistor for the on-chip oscillator.

AC ELECTRICAL CHARACTERISTICS(Over the operating rating, TA= -10°C~ +40°C, VDD=4.0V±10%)

PARAMETER	SYMBOL	TEST CONDITIONS	MIN	TYP	MAX	UNITS
Oscillator Frequency*	Fosc	TA=25°C,R=200KΩ	102	128	154	KHz
SI Pin Vpp Receive Sensitivity	VSI	Guaranteed Effective Decoding	300			mV
Cycle Time of Function Code	TFUN	Fosc=128KHz	0.75	1	1.25	ms
Cycle Time of Start Code	TSTA	Fosc=128KHz	1.5	2	2.5	ms

Note\*:The relative error between the frequencies of the two on-chip oscillators in the RCT02 and RCR02 must be less than ±25%

BIT FORMAT FOR THE RECEIVED SIGNAL (W1 is used for function codes,W2 for start codes)

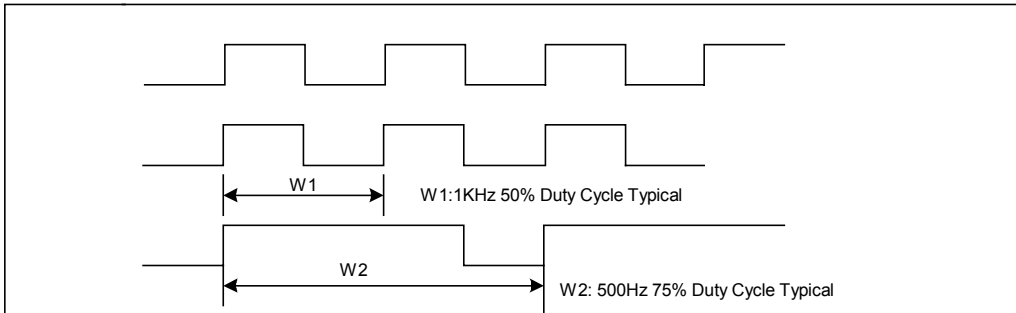

WORD FORMAT FOR RECEIVED SIGNAL

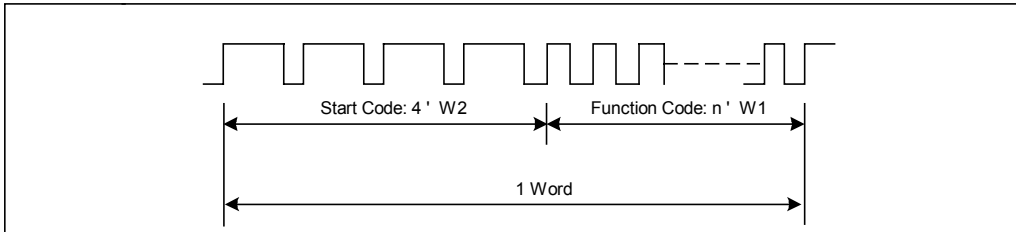

ENCODING INPUT FORMAT AND DECODING RESULT

W2 W2 W2 W2 (n)' W1 W2 W2 W2 W2 (n)' W1 W2 W2 W2 W2 (n)' W1 W2 W2 W2 W2 (n)' W1-----

Number of Function Codes(n)W1	Decoding Result
4	End Code
10	Forward
16	Forward
22	Turbo
28	Forward & Left
34	Forward & Right
40	Backward
46	Backward & Right
52	Backward & Left
58	Left
64	Right

DECODING TIMING

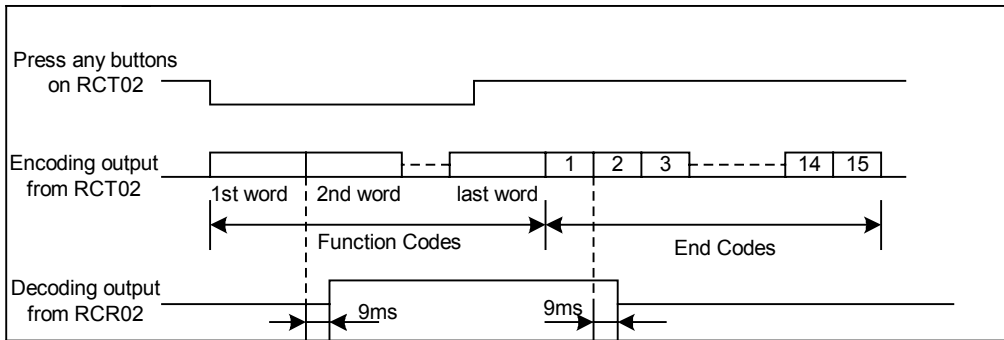

BLOCK DIAGRAM OF APPLICATION CIRCUIT

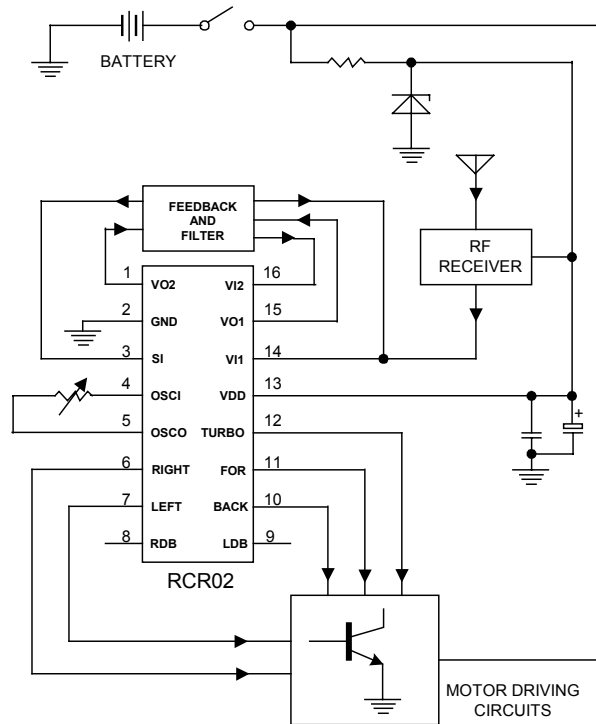

TYPICAL APPLICATION FOR RECEIVE CIRCUIT WITH FIVE FUNCTION

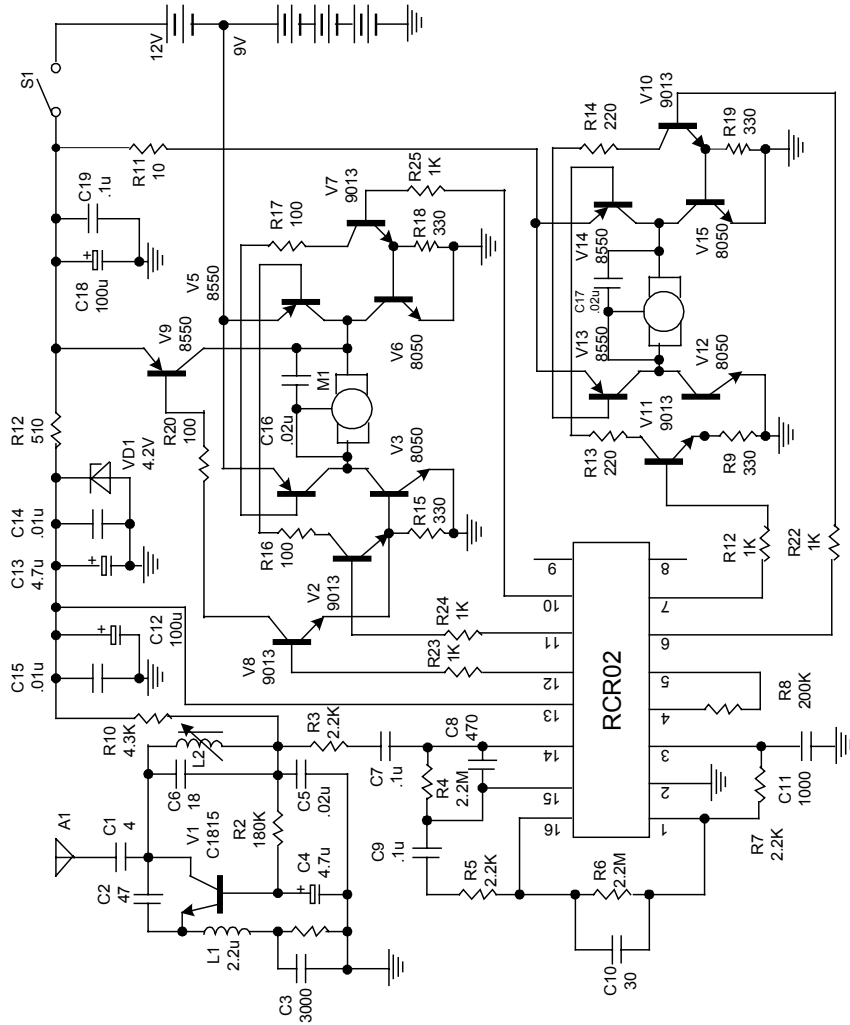

UTC assumes no responsibility for equipment failures that result from using products at values that exceed, even momentarily, rated values (such as maximum ratings, operating condition ranges, or other parameters) listed in products specifications of any and all UTC products described or contained herein. UTC products are not designed for use in life support appliances, devices or systems where malfunction of these products can be reasonably expected to result in personal injury. Reproduction in whole or in part is prohibited without the prior written consent of the copyright owner. The information presented in this document does not form part of any quotation or contract, is believed to be accurate and reliable and may be changed without notice.