

W83L785R/W83L785G
Winbond H/W
Monitoring IC



W83L785R Data Sheet Revision History

	PAGES	DATES	VERSION	VERSION ON WEB	MAIN CONTENTS
1	n.a.			n.a.	All the version before 0.50 are for internal use.
2	n.a.	8/01	0.6	n.a.	First publication.
3	n.a.	4/02	1.0	1.0	Change version and version on web site to 1.0
4	n.a.	4/06	1.1	1.1	Add Lead-free Package

Please note that all data and specifications are subject to change without notice. All the trade marks of products and companies mentioned in this data sheet belong to their respective owners.

LIFE SUPPORT APPLICATIONS

These products are not designed for use in life support appliances, devices, or systems where malfunction of these products can reasonably be expected to result in personal injury. Winbond customers using or selling these products for use in such applications do so at their own risk and agree to fully indemnify Winbond for any damages resulting from such improper use or sales.



Table of Contents-

1.	GENERAL DESCRIPTION	1
2.	FEATURES	2
2.1	Monitoring Items.....	2
2.2	Actions Enabling	2
2.3	General	2
2.4	Package	2
3.	KEY SPECIFICATIONS	2
4.	PIN CONFIGURATION	3
5.	PIN DESCRIPTION.....	4
6.	FUNCTIONAL DESCRIPTION	6
6.1	General Description	6
6.2	Access Interface.....	6
6.2.1	The first serial bus access timing is shown as follow:.....	6
6.3	Monitoring Time	7
6.4	Analog Inputs	7
6.4.1	Voltage Monitor input can not be over 2.048V:.....	8
6.5	Temperature Measurement Machine.....	8
6.5.1	Monitor temperature from thermistor:	9
6.5.2	Monitor temperature from Pentium IITM thermal diode	9
6.5.3	Over Temperature signal (OVT#).....	9
6.5.4	Temperature Fault (Temp_fault #).....	10
6.6	FAN Speed Count and FAN Speed Control	11
6.6.1	Fan speed count.....	11
6.6.2	Fan speed control.....	12
6.7	SMI#.....	12
6.7.1	Temperature.....	12
6.7.2	Voltage	14
6.7.3	Fan	14
7.	CONTENT OF DATA REGISTERS	15
7.1	Configuration Register — Index 40h.....	15
7.2	SMI# Status Register 1 — Index 41h.....	15
7.3	Reserved — Index 42h	16
7.4	SMI# Mask Register 1 — Index 43h	16
7.5	Reserved — Index 44h	16
7.6	Real Time Hardware Status Register I — Index 45h.....	17



7.7	Reserved — Index 46h	17
7.8	Fan Divisor Register — Index 47h	18
7.9	FANIN1/GPO1, FANIN2/GPO2, SMI#/GPO7, and OVT#/GPIO8 Control Register — Index 48h	18
7.10	TEMP_FAULT#/GPIO11, +2.5V/GPO14, +1.5V/GPO15, and VCORE/GPO16 Control Register — Index 49h	20
7.11	GPIO1/2, GPIO7/8, and GPIO11/14/15/16 Output Control Register — Index 4Ah.....	21
7.12	GPIO5, GPIO6, and GPIO13 Control Register — Index 4Bh.....	21
7.13	Winbond Vendor ID (Low Byte) — Index 4Ch	22
7.14	Winbond Vendor ID (High Byte) — Index 4Dh	22
7.15	Chip ID — Index 4Eh	22
7.16	Reserved — Index 4Fh	22
7.17	OVT# Property Select — Index 50h.....	22
7.18	SMI# Property Select — Index 51h.....	23
7.19	Thermal Sensor 1/2 Type Register — Index 52h	24
7.20	Temperature Sensor 1 Fault Limit — Index 53h.....	24
7.21	Temperature Sensor 2 Fault Limit — Index 54h.....	24
7.22	Reserved — Index 55h ~ 7Fh.....	24
7.23	PWM 1 Pre-Scale Register — Index 80h	25
7.24	PWM 1 Duty Cycle Select Register — 81h.....	25
7.25	PWM 2 Pre-Scale Register — Index 82h	26
7.26	PWM2 Duty Cycle Select Register — Index 83h.....	26
7.27	Reserved Register — Index 84h.....	26
7.28	Temperature Sensor 1 (for Environment) Offset Register — Index 85h	27
7.29	Temperature Sensor 2 (for CPU) Offset Register — Index 86h.....	27
8.	VALUE RAM AND LIMIT VALUE.....	28
8.1	Value RAM — Index 20h- 3Fh or 60h - 7Fh	28
9.	SPECIFICATIONS	29
9.1	Absolute Maximum Ratings	29
9.2	DC Characteristics	29
9.3	AC Characteristics	30
10.	HOW TO READ THE TOP MARKING.....	31
11.	PACKAGE DRAWING AND DIMENSIONS.....	32
12.	W83L785R SCHEMATICS	33



1. GENERAL DESCRIPTION

W83L785R/G is a condensed product of W83L784R/G --- Winbond's most popular hardware monitoring IC for notebook. Specifically designed for the graphic cards and notebook systems, W83L785R can be used to monitor several critical hardware parameters of the system, including voltages, fan speeds, and temperatures, which are very important for the system to work stably and properly.

An 8-bit analog-to-digital converter (ADC) was built inside W83L785R/G. The W83L785R/G can monitor 4 analog voltage inputs, 2 fan tachometer inputs, 2 remote temperature sensors. The remote temperature sensing can be performed by thermistors, or connected from IntelTM Deschutes CPU thermal diode output. The W83L785R/G provides 2 PWM (pulse width modulation) outputs for the fan speed control. Also the W83L785R/G provides: SMI#, OVT#, Temp fault, GPIO signals for system protection events; I²CTM serial bus interface. W83L785R/G also provides 3 pure GPIO and 8 multifunctional GPIO pins, and powered by 3.3V.

Through the application software or BIOS, the users can read all the monitored parameters of system from time to time. And a pop-up warning can be also activated when the monitored item was out of the proper/preset range. The application software could be Winbond's Hardware DoctorTM, or IntelTM LDCM (LanDesk Client Management), or other management application software. Also the users can set up the upper and lower limits (alarm thresholds) of these monitored parameters and to activate one programmable and maskable interrupts. For the spacing saving consideration of the Notebook system, W83L785R/G is in the package of 209mil 20pins-SSOP.



2. FEATURES

2.1 Monitoring Items

- 2 thermal inputs from remote thermistors or Pentium™ II (Deschutes) thermal diode output
- 4 voltage inputs
--- typical for Vcore, +3.3V (Power), +2.5V, +1.5V
- 2 sets of PWM fan speed control
- WATCHDOG comparison of all monitored values
- Programmable hysteresis and setting points (alarm thresholds) for all monitored items

2.2 Actions Enabling

- 2 PWM (pulse width modulation) outputs for fan speed control
--- Total up to 2 sets of fan speed monitoring and controlling
- Issue temperature fault signal as the temperature of the system/CPU exceeds its limit.
- Issue SMI#, OVT#, GPIO and Temp. Fault signals to activate system protection
- Warning signal pop-up in application software

2.3 General

- I²C™ serial bus interface
- Intel™ LDCM (DMI driver 2.0) support
- Winbond hardware monitoring application software (Hardware Doctor™) support, for both Windows 95/98 and Windows NT 4.0/5.0
- Meet WFM 2.0 (Wired for Management) spec.
- 3.3V VCC operation

2.4 Package

- 20-pin SSOP (209mil)

3. KEY SPECIFICATIONS

- Voltage monitoring accuracy ±1% (Max)
- Monitoring Temperature Range and Accuracy
- 40°C to +120°C ± 3°C(Max)
- Supply Voltage 2.7V ~ 5.5V
- Operating Supply Current 2 mA typ.
- Power Down Supply Current 10 uA typ.
- ADC Resolution 8 Bits

4. PIN CONFIGURATION

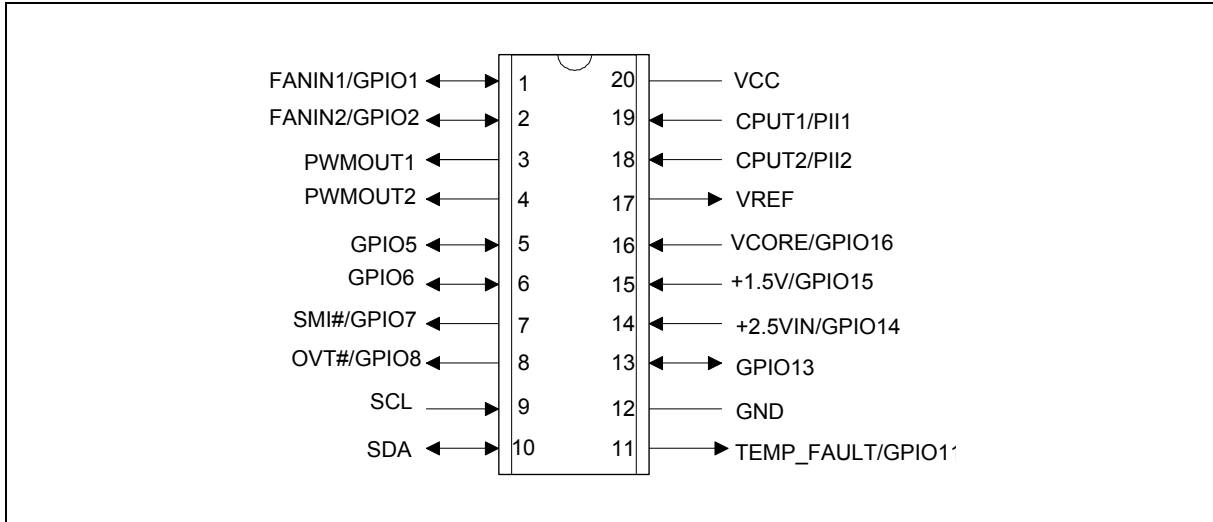



5. PIN DESCRIPTION

I/O_{12t} - TTL level bi-directional pin with 12 mA source-sink capability, open drain output

I/O_{12ts} - TTL level and schmitt trigger

OUT₁₂ - Output pin with 12 mA source-sink capability

AOUT - Output pin(Analog)

OD₁₂ - Open-drain output pin with 12 mA sink capability

IN_t - TTL level input pin

IN_{ts} - TTL level input pin and schmitt trigger

AIN - Input pin(Analog)

PIN NAME	PIN NO.	TYPE	DESCRIPTION
FANIN1 / GPIO1	1	IN _{ts} / I/OD _{12ts}	0V to +3.3V amplitude fan tachometer input.(Default) / General purpose I/O function. This multi-functional pin is programmable.
FANIN2 / GPIO2	2	IN _{ts} / OUT ₁₂	0V to +3.3V amplitude fan tachometer input. (Default) / General purpose I/O function. This multi-functional pin is programmable.
PWMOUT1	3	OD ₁₂	Fan speed control PWM output. This pin is open-drain
PWMOUT2	4	OD ₁₂	Fan speed control PWM output. This pin is open-drain
GPIO5	5	I/OD _{12ts}	General purpose I/O function.
GPIO6	6	I/OD _{12ts}	General purpose I/O function.
SMI#/ GPIO7	7	OD ₁₂ I/OD _{12ts}	System Management Interrupt. General purpose I/O function. This multi-functional pin is programmable.
OVT#/ GPIO8	8	OD ₁₂ I/OD _{12ts}	Over temperature Shutdown Output. General purpose I/O function. This multi-functional pin is programmable.
SCL	9	IN _{ts}	Serial Bus Clock.
SDA	10	I/OD ₁₂	Serial Bus bi-directional Data.
TEMP_FAUL T#/ GPIO11	11	OD ₁₂ I/OD _{12ts}	Active-Low output. This pin will be a logic LOW when the temperature of the system or CPU exceeds its limit. (Default) / General purpose I/O function. This multi-functional pin is programmable.
GND	12	Ground	Ground.
GPIO13	13	I/OD _{12ts}	General purpose I/O function. Default Open drain.
+2.5V/ GPIO14	14	AIN I/OD _{12ts}	0V to 2.048V FSR Analog Inputs. (This pin is connected to the +2.5V). General purpose I/O function. This multi-functional pin is programmable.

W83L785R/W83L785G



Pin Description, continued

PIN NAME	PIN NO.	TYPE	DESCRIPTION
+1.5V/ GPIO15	15	AIN I/OD _{12ts}	0V to 2.048V FSR Analog Inputs. (This pin is connected to the +1.5V). General purpose I/O function. This multi-functional pin is programmable.
VCORE/ GPIO16	16	AIN I/OD _{12ts}	0V to 2.048V FSR Analog Inputs. (This pin connected to VCORE) General purpose I/O function. This multi-functional pin is programmable.
VREF	17	AOUT	Reference Voltage.
CPUT2 / PII2	18	AIN	Thermistor terminal input.(Default) / Pentium™ II diode input. This multi-functional pin is programmable.
CPUT1 / PII1	19	AIN	Thermistor terminal input.(Default) / Pentium™ II diode input. This multi-functional pin is programmable.
VCC	20	POWER	+3.3 VCC power supply input.



6. FUNCTIONAL DESCRIPTION

6.1 General Description

The W83L785R/G provides most 4 analog positive inputs, 2 fan speed monitors, 2 sets for fan PWM (Pulse Width Modulation) control, 2 remote thermal inputs from remote thermistors or 2N3904 transistors or Pentium™ II (Deschutes) thermal diode outputs. W83L785R/G also provides software power down this chip to save power, but I2C interface is still working. When W83L785R/G starts the monitor function on the chip, the Watch Dog machine monitors every function and store the value to registers. If the monitor value exceeds the limit value, the interrupt status will be set to 1.

6.2 Access Interface

The W83L785R/G provides I²C Serial Bus to read/write internal registers. In the W83L785R/G, the I2C address defined value is 0101101.

6.2.1 The first serial bus access timing is shown as follow:

(a) Serial bus write to internal address register followed by the data byte

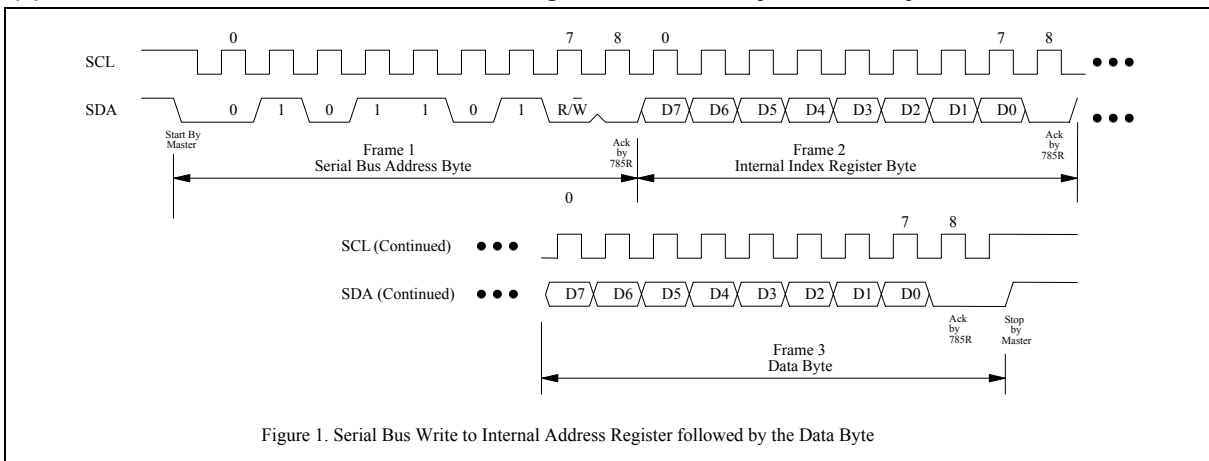

Figure 1. Serial Bus Write to Internal Address Register followed by the Data Byte

(b) Serial bus read from internal address register followed by the data byte

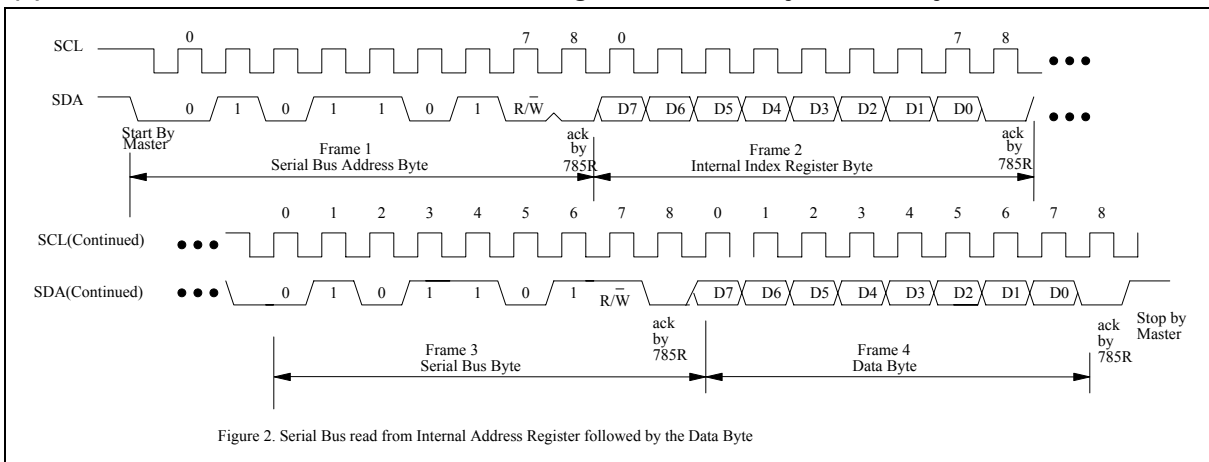

Figure 2. Serial Bus read from Internal Address Register followed by the Data Byte

6.3 Monitoring Time

The W83L785R/G monitoring time includes temperature's conversion time, voltage's conversion time, and fan's count time. The W83L785R/G sample rate is 22.5 KHz. The temperature's conversion time need 24 cycles (worst case). The voltage's ADC conversion time need 16 cycles (worst case). The fan conversion cycle is divisor * count cycles. The W83L785R/G has 4 sets voltage, 2 sets temperature, and 2 sets fans.

2 sets temperature monitor time: $2 * 24 * 0.044\text{mS} = 2.112 \text{ mS}$

4 sets voltage: $4 * 16 * 0.044 = 2.816 \text{ mS}$

EX: fan=4000RPM

Divisor =2, count=169

Fan transform time= $0.044 * 2 * 169 = 14.872\text{mS}$

2 Fan transform time= $14.872 \text{ mS} * 2 = 29.744 \text{ mS}$

Total monitor time = $2.8 + 2.1 + 29.7 = 34.6 \text{ mS}$

6.4 Analog Inputs

The maximum input voltage of the analog pin is 2.048V because the 8-bit ADC has the 8mV LSB. Actually, the application of the voltage monitoring would most often be connected to power suppliers. The +1.5V voltage can directly connected to these analog inputs. The +2.5V and CPU VOCRE, the inputs higher than 2.048V, should be reduced a factor with external resistors so as to obtain the input range. As Figure 3 shows.

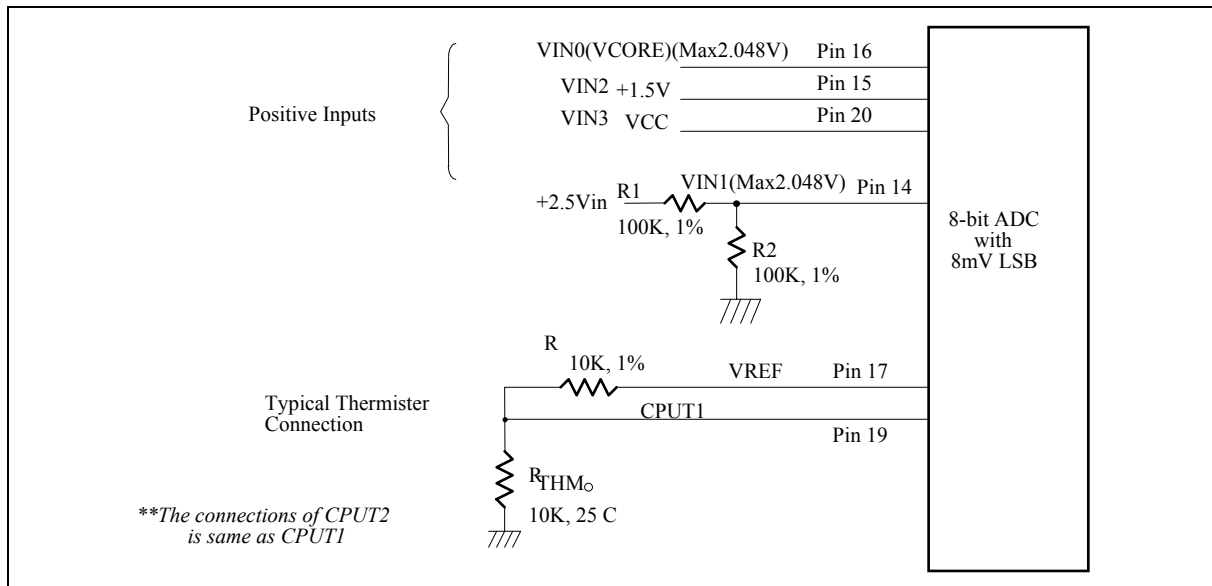

Figure. 3.



6.4.1 Voltage Monitor input can not be over 2.048V:

The input voltage VIN1 or Vcore can be expressed as following equation:

$$VIN1 = V_{+2.5V} \times \frac{R_2}{R_1 + R_2} \quad . \quad V_{+2.5V} \text{ is } +2.5V \text{ inputs.}$$

The value of R1 and R2 can be selected to 100K Ohms and 100K Ohms, respectively, when the input voltage is 2.5V. The node voltage of VIN3 can be subject to less than 2.048V for the maximum input range of the 8-bit ADC. The pin 20 is connected to the power supply VCC with +3.3V. There are two functions in this pin with 3.3V. The first function is to supply internal analog power of the W83L785R /G and the second function is that this voltage with 3.3V is connected to internal serial resistors to monitor the +3.3V voltage. The values of two serial resistors are 20K ohms and 40K ohms so that input voltage to ADC is 1.1V which is less than 2.048V of ADC maximum input voltage. The express equation can represent as follows.

$$V_{in} = VCC \times \frac{20K\Omega}{20K\Omega + 40K\Omega} \cong 1.1V$$

where VCC is set to 3.3V.

6.5 Temperature Measurement Machine

The temperature data format is 8-bit two-complement for thermal sensor. The 8-bit temperature data can be obtained by reading the CR [26h] or CR [27h]. The format of the temperature data is show in Table 1.

Table 1

TEMPERATURE	8-BIT DIGITAL OUTPUT	
	8-BIT BINARY	8-BIT HEX
+125°C	0111,1101	7Dh
+25°C	0001,1001	19h
+2°C	0000,0010	02h
+1°C	0000,0001	01h
+0°C	0000,0000	00h
-1°C	1111,1111	FFh
-2°C	1111,1110	FEh
-25°C	1110,0111	E7h
-55°C	1100,1001	C9h

6.5.1 Monitor temperature from thermistor:

The W83L785R/G can connect two thermistors to measure three different environment temperature or remote temperature. The specification of thermistor should be considered to (1) β value is 3435K, (2) resistor value is 10K ohms at 25°C. In the Figure 3, the themistor is connected by a serial resistor with 10K Ohms, and then connected to VREF (pin 17).

6.5.2 Monitor temperature from Pentium IITM thermal diode

The W83L785R/G can alternate the thermistor to Pentium II™ (Deschutes) thermal diode interface and the circuit connection is shown as Figure 4. The pin of Pentium II™ D- is connected to power supply ground (GND) and the pin D+ is connected to pin PIITx in the W83L785R/G. The resistor R=15K ohms should be connected to VREF to supply the diode bias current and the bypass capacitor C=3300pF should be added to filter the high frequency noise.

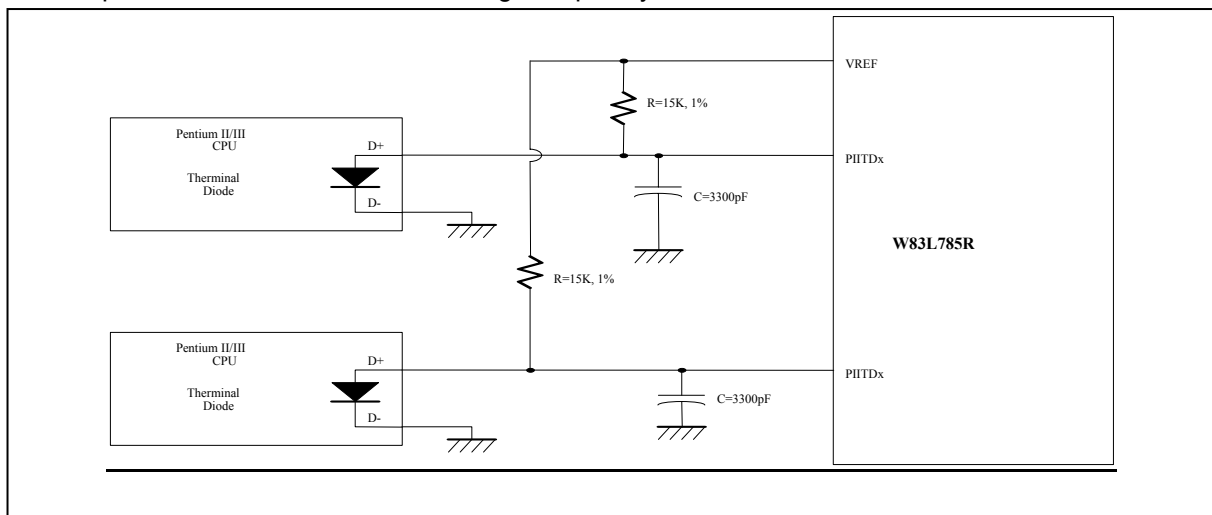

Figure 4.

6.5.3 Over Temperature signal (OVT#)

W83L785R/G provides two external thermal sensors to detect temperature. When detected temperature exceeds the over-temperature value, pin OVT# will be asserted until the temperature goes below the hysteresis temperature. Pin OVT# has 2 operating modes.

6.5.3.1. Comparator Mode:

At this mode, temperature exceeding T_O causes the OVT# output activated until the temperature is less than T_{HYST} . (Figure 5)

6.5.3.2. Interrupt Mode:

At this mode, temperature exceeding T_O causes the OVT# output activated indefinitely until reset by reading interrupt status register. Temperature exceeding T_O , then OVT# asserted, and then temperature going below T_{HYST} will also cause the OVT# activated indefinitely until reset by reading temperature sensor1 or sensor2 registers. Once the OVT# is activated by exceeding T_O , then reset, if the temperature remains above T_{HYST} , the OVT# will not be activated again. (Figure 5)

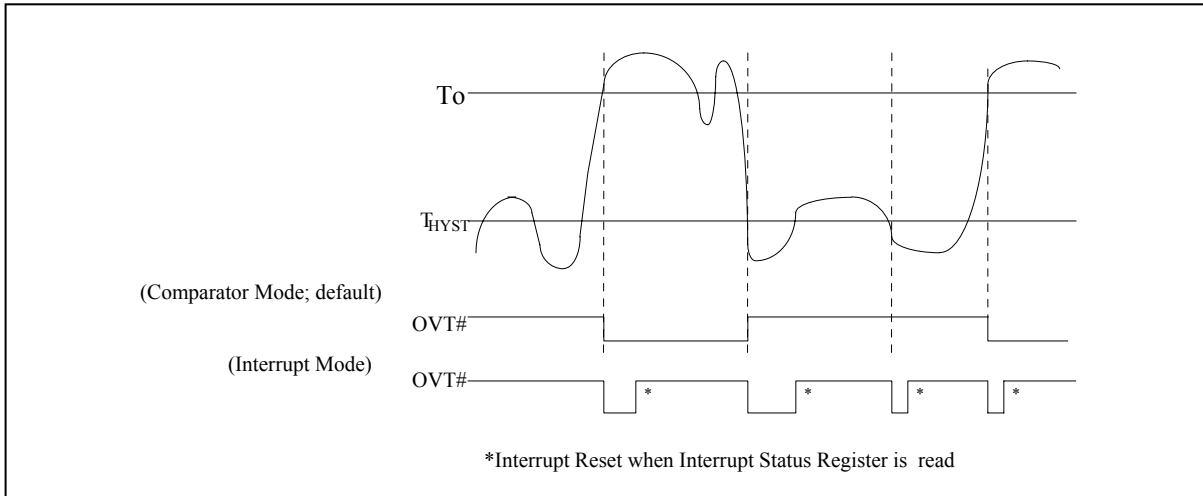

Figure 5

6.5.4 Temperature Fault (Temp_fault #)

W83L785R/G provides a good protection for temperature. Setting pin11 (TEMP_FAULT#) to monitor temperature and enable TEMP_FAULT# function. When VTIN1 (Pin19) or VTIN (Pin18) temperature exceeds Temperature fault limit in CR53, or R54 pin11 TEMP_FAULT# will be asserted. (Figure 6)

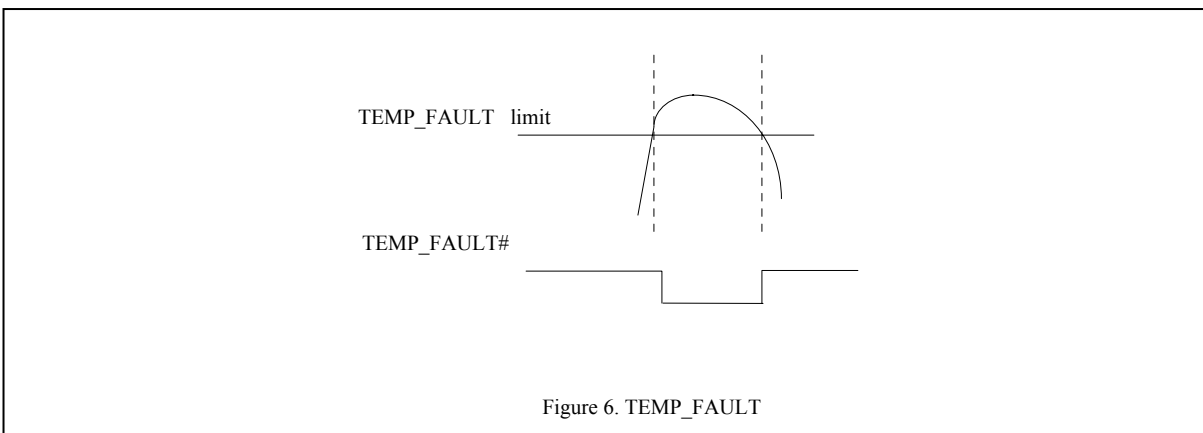

Figure 6. TEMP_FAULT

6.6 FAN Speed Count and FAN Speed Control

6.6.1 Fan speed count

Inputs are provided by the signals from fans equipped with tachometer outputs. The level of these signals should be set to TTL level, and maximum input voltage cannot be over VCC. If the input signals from the tachometer outputs are over the VCC, the external trimming circuit should be added to reduce the voltage to obtain the input specification. The normal circuit and trimming circuits are shown as Figure 7.

Determine the fan counter according to:

$$Count = \frac{1.35 \times 10^6}{RPM \times Divisor}$$

In other words, the fan speed counter has been read from register CR28 or CR29, the fan speed can be evaluated by the following equation.

$$RPM = \frac{1.35 \times 10^6}{Count \times Divisor}$$

The default divisor is 2 and defined at CR47.bit0~2, bit4~6 which are three bits for divisor. That provides very low speed fan counter such as power supply fan. The followed table is an example for the relation of divisor, RPM, and count.

Table 2

DIVISOR	NOMINAL RPM	TIME PER REVOLUTION	COUNTS	70% RPM	TIME FOR 70%
1	8800	6.82 ms	153	6160	9.74 ms
2 (default)	4400	13.64 ms	153	3080	19.48 ms
4	2200	27.27 ms	153	1540	38.96 ms
8	1100	54.54 ms	153	770	77.92 ms
16	550	109.08 ms	153	385	155.84 ms
32	275	218.16 ms	153	192	311.68 ms
64	137	436.32 ms	153	96	623.36 ms
128	68	872.64 ms	153	48	1246.72 ms

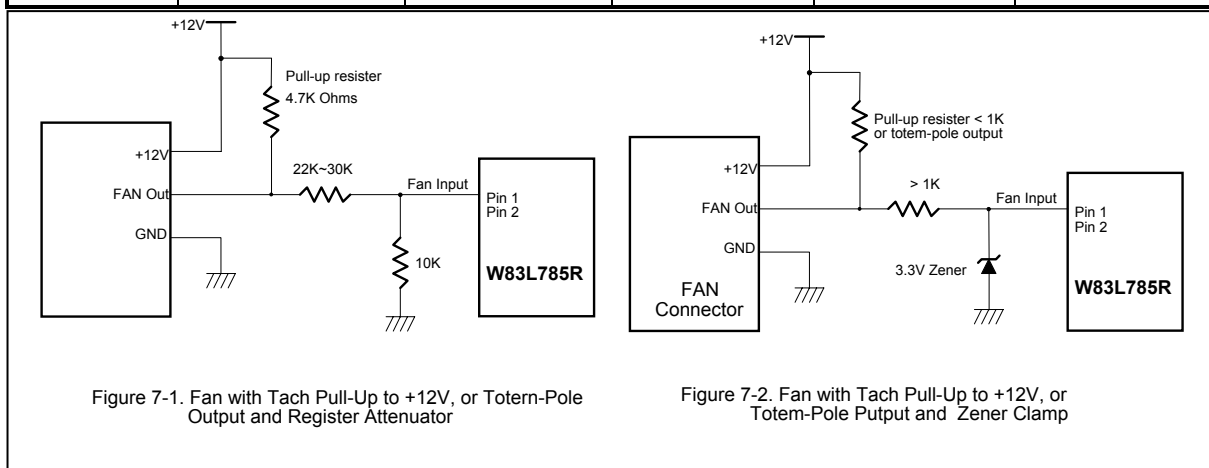

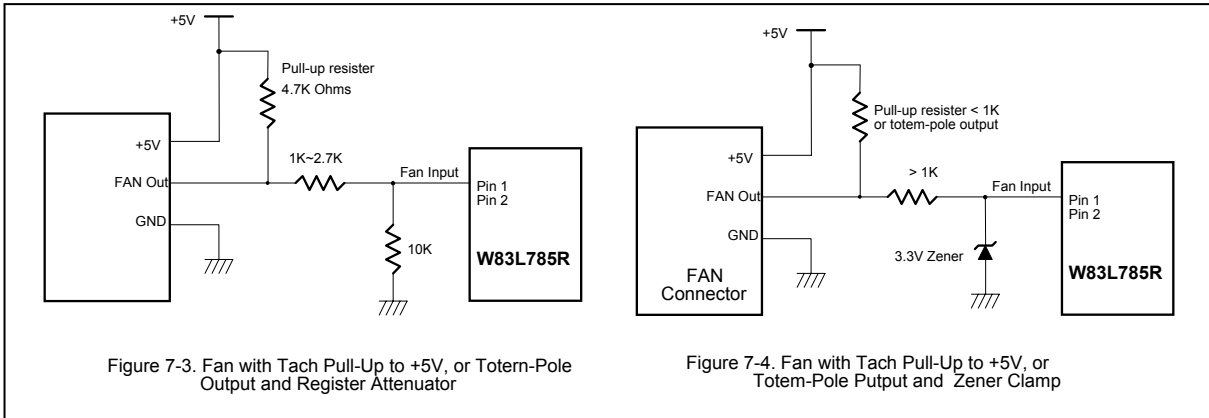

6.6.2 Fan speed control

The W83L785R/G provides two sets for fan PWM speed control. The duty cycle of PWM can be programmed by an 8-bit register which are defined in the CR81h and CR83h. The default duty cycle is set to 100%, that is, the default 8-bit registers is set to FFh. The expression of duty can be represented as follows.

$$\text{Duty - cycle (\%)} = \frac{\text{Programmed 8 - bit Register Value}}{255} \times 100 \%$$

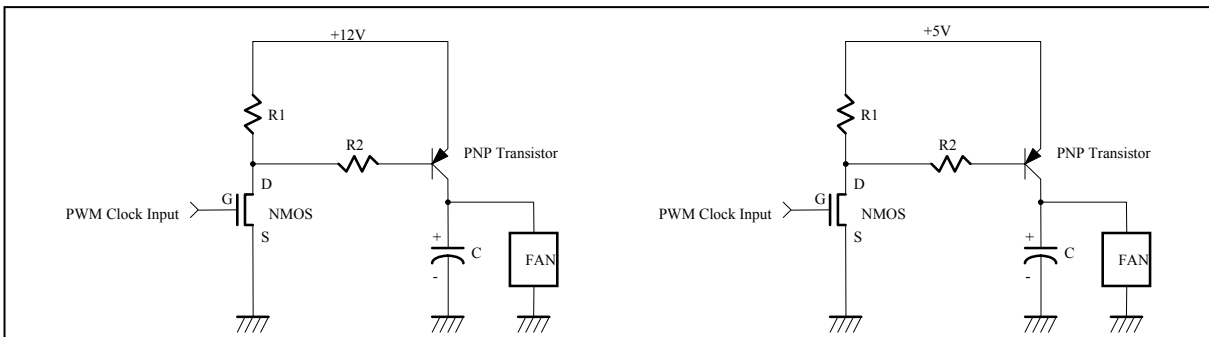

Figure 8

6.7 SMI#

6.7.1 Temperature

Pin SMI# for temperature has 3 modes.

6.7.1.1. Comparator Interrupt Mode

Temperature exceeding T_O causes an interrupt and this interrupt will be reset when reading all of the Interrupt Status Registers. Once an interrupt event has occurred by exceeding T_O , then reset, if the temperature remains above the T_{HYST} , the interrupt will occur again when the next conversion has completed. If an interrupt event has occurred by exceeding T_O and not reset, the interrupts will not occur again. The interrupts will continue to occur in this manner until the temperature goes below T_{HYST} . (Figure 9-1)



6.7.1.2. Two-Times Interrupt Mode

Temperature exceeding T_O causes an interrupt and then temperature going below T_{HYST} will also cause an interrupt if the previous interrupt has been reset by reading all the interrupt Status Register. Once an interrupt event has occurred by exceeding T_O , then reset, if the temperature remains above the T_{HYST} , the interrupt will not occur. (Figure 9-2)

6.7.1.3. One-Time Interrupt Mode

Temperature exceeding T_O causes an interrupt and then temperature going below T_{HYST} will not cause an interrupt. Once an interrupt event has occurred by exceeding T_O , then going below T_{HYST} , an interrupt will not occur again until the temperature exceeding T_O . (Figure 9-3)

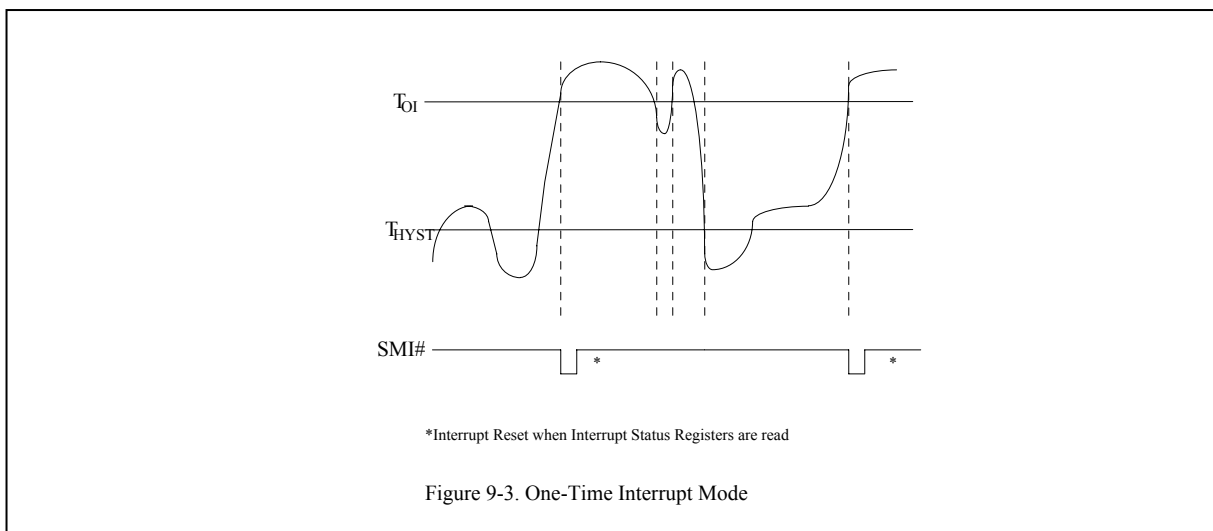
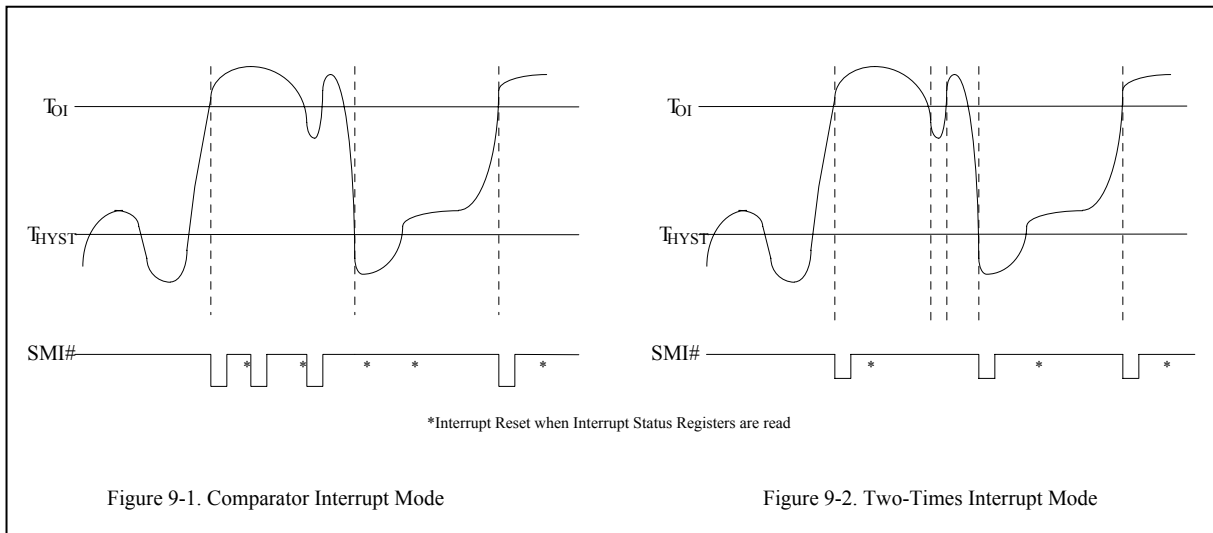



6.7.2 Voltage

SMI# interrupt for voltage is Two-Times Interrupt Mode. Voltage exceeding high limit or going below low limit will causes an interrupt if the previous interrupt has been reset by reading all the interrupt Status Register. (Figure 10-1)

6.7.3 Fan

SMI# interrupt for fan is Two-Times Interrupt Mode. Fan count exceeding the limit, or exceeding and then going below the limit (set at value ram index 3Bh and 3Ch), will causes an interrupt if the previous interrupt has been reset by reading all the interrupt Status Register. (Figure 10-2)

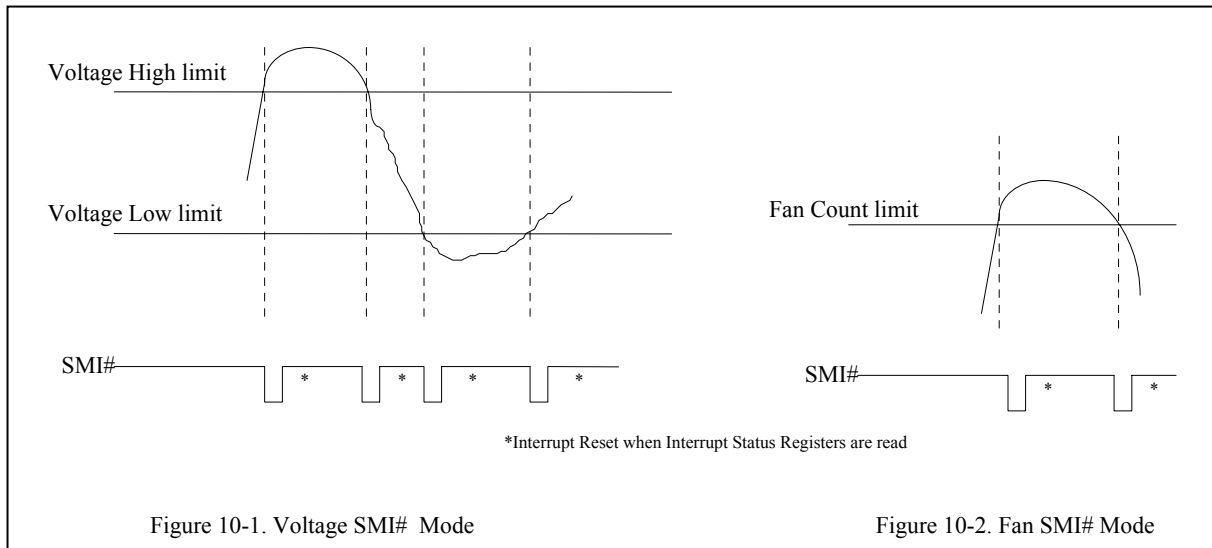



7. CONTENT OF DATA REGISTERS

7.1 Configuration Register — Index 40h

Power on default [7:0] = 0000, 0001 b

BIT	NAME	READ/WRITE	DESCRIPTION
7	INITIALIZATION	Read/Write	A one restores power on default value to all registers except the Serial Bus Address register. This bit clears itself since the power on default is zero.
6-5	Reserved	Read/Write	Reserved
4	SOFT_PWDN	Read/Write	Software Power Down. If set to 1 to power down this chip, but I2C interface is still working.
3	EN_T2_FAULT	Read/Write	Enable Temperature 2 Fault Function. When temperature 2 is out of the Temperature Fault Limit value (defined Index 54), the Pin 11 will go to low level. This function is wire-or with temperature 1 fault if temperature 1 fault function is enable.
2	EN_T1_FAULT	Read/Write	Enable Temperature 1 Fault Function. When temperature 1 is out of the Temperature Fault Limit value (defined Index 53), the Pin 11 will go to low level. This function is wire-or with temperature 2 fault if temperature 2 fault function is enable.
1	INT_CLEAR	Read/Write	A one disables the SMI# outputs without affecting the contents of Interrupt Status Registers. The device will stop monitoring. It will resume upon clearing of this bit.
0	START	Read/Write	A one enables startup of monitoring operations, a zero puts the part in standby mode. Note: The outputs of Interrupt pins will not be cleared if the user writes a zero to this location after an interrupt has occurred unlike "INT_Clear" bit.

7.2 SMI# Status Register 1 — Index 41h

Power on default [7:0] = 0000, 0000 b

BIT	NAME	READ/WRITE	DESCRIPTION
7	TEMP2	Read Only	A one indicates a High or Low limit has been exceeded from temperature sensor 2. (CPUT2/PII2)
6	TEMP1	Read Only	A one indicates a High or Low limit has been exceeded from temperature sensor 1. (CPUT1/PII1)
5	FAN2	Read Only	A one indicates the fan count limit has been exceeded.
4	FAN1	Read Only	A one indicates the fan count limit has been exceeded.
3	VCC	Read Only	A one indicates a High or Low limit has been exceeded. (VCC, +3.3V)



SMI# Status Register 1 — Index 41h, continued.

BIT	NAME	READ/WRITE	DESCRIPTION
2	+1.5V	Read Only	A one indicates a High or Low limit has been exceeded. (+1.5V)
1	+2.5V	Read Only	A one indicates a High or Low limit has been exceeded. (+2.5V)
0	VCORE	Read Only	A one indicates a High or Low limit has been exceeded. (Vcore A)

7.3 Reserved — Index 42h

Reserved

7.4 SMI# Mask Register 1 — Index 43h

Power on default <7:0> = 0000, 0000 b

BIT	NAME	READ/WRITE	DESCRIPTION
7	MSK_T2_SMI	Read/Write	A one disables the corresponding interrupt status bit for SMI# interrupt. (Temperature 2)
6	MSK_T1_SMI	Read/Write	A one disables the corresponding interrupt status bit for SMI# interrupt. (Temperature 1)
5	MSK_FAN2_SMI	Read/Write	A one disables the corresponding interrupt status bit for SMI# interrupt. (Fan 2 speed counter)
4	MSK_FAN1_SMI	Read/Write	A one disables the corresponding interrupt status bit for SMI# interrupt. (Fan 1 speed counter)
3	MSK_VCC_SMI	Read/Write	A one disables the corresponding interrupt status bit for SMI# interrupt. (VCC, +3.3V)
2	MSK_+1.5V_SMI	Read/Write	A one disables the corresponding interrupt status bit for SMI# interrupt. (+1.5V)
1	MSK_+2.5V_SMI	Read/Write	A one disables the corresponding interrupt status bit for SMI# interrupt. (+2.5V)
0	MSK_VCORE_SMI	Read/Write	A one disables the corresponding interrupt status bit for SMI# interrupt. (Vcore)

7.5 Reserved — Index 44h

Read to return 00h.



7.6 Real Time Hardware Status Register I — Index 45h

Power on - [7:0] = 0000, 0000 b

BIT	NAME	READ/WRITE	DESCRIPTION
7	TEMP2_STS	Read Only	Temperature sensor 2 Status. Set 1, the voltage of temperature sensor is over the limit value. Set 0, the voltage of temperature sensor is during the limit range.
6	TEMP1_STS	Read Only	Temperature sensor 1 Status. Set 1, the voltage of temperature sensor is over the limit value. Set 0, the voltage of temperature sensor is during the limit range.
5	FAN2_STS	Read Only	FAN 2 Status. Set 1, the fan speed counter is over the limit value. Set 0, the fan speed counter is in the limit range.
4	FAN1_STS	Read Only	FAN 1 Status. Set 1, the fan speed counter is over the limit value. Set 0, the fan speed counter is in the limit range.
3	VCC_STS	Read Only	VCC (3+.3V) Voltage Status. Set 1, the voltage of VCC (+3.3V) is over the limit value. Set 0, the voltage of VCC (+3.3V) is in the limit range.
2	+1.5V_STS	Read Only	+1.5V Voltage Status. Set 1, the voltage of +1.5V is over the limit value. Set 0, the voltage of +1.5V is in the limit range.
1	+2.5V_STS	Read Only	+2.5V Voltage Status. Set 1, the voltage of +2.5V is over the limit value. Set 0, the voltage of +1.5V is in the limit range.
0	VCORE_STS	Read Only	VCORE Voltage Status. Set 1, the voltage of VCORE is over the limit value. Set 0, the voltage of VCORE is in the limit range.

7.7 Reserved — Index 46h

Read to return 00h.



7.8 Fan Divisor Register — Index 47h

Power on default [7:0] = 0001, 0001 b

BIT	NAME	READ/WRITE	DESCRIPTION
7	Reserved	Read/write	Reserved.
6-4	F2_SP_CRTL[2:0]	Read/Write	FAN2 Speed Control. 000 - divide by 1; 001 - divide by 2; 010 - divide by 4; 011 - divide by 8. 100 - divide by 16. 101 - divide by 32. 110 - divide by 64. 111 - divide by 128.
3	Reserved	Read/write	Reserved.
2-0	F1_SP_CTRL[2:0]	Read/Write	FAN1 Speed Control. 000 - divide by 1; 001 - divide by 2; 010 - divide by 4; 011 - divide by 8. 100 - divide by 16. 101 - divide by 32. 110 - divide by 64. 111 - divide by 128.

7.9 FANIN1/GPO1, FANIN2/GPO2, SMI#/GPO7, and OVT#/GPIO8 Control Register — Index 48h

Power on default [7:0] = 0000, 0000 b

BIT	NAME	READ/WRITE	DESCRIPTION
7	GPIO8_VAL	Read/Write	GPIO8 Output Value. GPIO8 output value if EN_GPIO8 is set to 1. Write 1, then pin 8 (GPIO8) always generate logic high signal. Write 0, pin 8 (GPIO8) always generates logic low signal. This bit default 0.
6	EN_GPIO8	Read/Write	Enable GPIO8 Function. Which enable multiple function pin 8, named OVT#/GPIO8, GPIO8 function. Set to 0 (default), pin 8 (OVT#/GPIO8) acts as OVT#. Set to 1, this pin 8 acts as GPIO8 control function and the output value of GPIO8 is programmed by this register bit 7.
5	GPIO7_VAL	Read/Write	GPIO7 Output Value. GPIO7 output value if EN_GPIO7 is set to 1. Write 1, then pin 7 (GPIO7) always generate logic high signal. Write 0, pin 7 (GPIO7) always generates logic low signal. This bit default 0.

W83L785R/W83L785G



FANIN1/GPO1, FANIN2/GPO2, SMI#/GPO7, and OVT#/GPIO8 Control Register — Index 48h, continued

BIT	NAME	READ/WRITE	DESCRIPTION
4	EN_GPIO7	Read/Write	Enable GPIO7 Function. Which enable multiple function pin 7, named SMI#/GPIO7, GPIO7 function. Set to 0 (default), pin 7 (SMI# /GPIO7) acts as SMI# which is fan count out of the limit value. Set to 1, this pin 7 acts as GPIO7 control function and the output value of GPIO7 is programmed by this register bit 5.
3	GPIO2_VAL	Read/Write	GPIO2 Output Value. GPIO2 output value if EN_GPIO2 is set to 1. Write 1, then pin 2 (GPIO2) always generate logic high signal. Write 0, pin 2 (GPIO2) always generates logic low signal. This bit default 0.
2	EN_GPIO2	Read/Write	Enable GPIO2 Function. Which enable multiple function pin 2, named FANIN2/GPIO2, GPIO2 function. Set to 0 (default), pin 2 (FANIN2/GPIO2) acts as FANIN2 which is fan clock input. Set to 1, this pin 2 acts as GPIO2 control function and the output value of GPIO2 is programmed by this register bit 3. This output pin GPIO2 can connect to power PMOS gate to control FAN ON/OFF.
1	GPIO1_VAL	Read/Write	GPIO1 Output Value. GPIO1 output value if EN_GPIO1 is set to 1. Write 1, then pin 1 (GPIO1) always generate logic high signal. Write 0, pin 1 (GPIO1) always generates logic low signal. This bit default 0.
0	EN_GPIO1	Read/Write	Enable GPIO1 Function. Which enable multiple function pin 1, named FANIN1/GPIO1, GPIO1 function. Set to 0 (default), pin 1 (FANIN1/GPIO1) acts as FANIN1 which is fan clock input. Set to 1, this pin 1 acts as GPIO1 control function and the output value of GPO1 is programmed by this register bit 1. This output pin GPIO1 can connect to power PMOS gate to control FAN ON/OFF.



7.10 TEMP_FAULT#/GPIO11, +2.5V/GPIO14, +1.5V/GPIO15, and VCORE/GPIO16 Control Register — Index 49h

Power on default [7:0] = 0000, 0000 b

BIT	NAME	READ/WRITE	DESCRIPTION
7	GPIO16_VAL	Read/Write	GPIO16 Output Value. GPIO16 output value if EN_GPIO16 is set to 1. Write 1, then pin 16 (GPIO16) always generate logic high signal. Write 0, pin 16 (GPIO16) always generates logic low signal. This bit default 0. Read this register will return this pin value.
6	EN_GPIO16	Read/Write	Enable GPIO16 Function. Which enable multiple function pin 16, named VCORE/GPIO16, GPIO16 function. Set to 0 (default), pin 16 (VCORE /GPIO16) acts as VCORE. Set to 1, this pin 16 acts as GPIO16 control function and the output value of GPIO16 is programmed by this register bit 7.
5	GPO15_VAL	Read/Write	GPIO15 Output Value. GPIO15 output value if EN_GPIO15 is set to 1. Write 1, then pin 15 (GPIO15) always generate logic high signal. Write 0, pin 15 (GPIO15) always generates logic low signal. This bit default 0. Read this register will return this pin value.
4	EN_GPIO15	Read/Write	Enable GPIO14 Function. Which enable multiple function pin 15, named +1.5V/GPIO15, GPIO15 function. Set to 0 (default), pin 15 (FANIN2/GPO2) acts as +1.5V which is monitor voltage input. Set to 1, this pin 15 acts as GPIO15 control function and the output value of GPIO15 is programmed by this register bit 5.
3	GPIO14_VAL	Read/Write	GPIO14 Output Value. GPIO14 output value if EN_GPIO14 is set to 1. Write 1, then pin 14 (GPIO14) always generate logic high signal. Write 0, pin 14 (GPO14) always generates logic low signal. This bit default 0. Read this register will return this pin value.
2	EN_GPIO14	Read/Write	Enable GPIO14 Function. Which enable multiple function pin 14, named +2.5V/GPIO14, GPIO14 function. Set to 0 (default), pin 14 (+2.5V/GPIO14) acts as +2.5V. Set to 1, this pin 1 acts as GPIO14 control function and the output value of GPIO14 is programmed by this register bit 3.
1	GPIO11_VAL	Read/Write	GPIO11 Output Value. GPIO11 output value if EN_GPIO11 is set to 1. Write 1, then pin11 (GPIO11) always generate logic high signal. Write 0, pin 11 (GPIO11) always generates logic low signal. This bit default 0. Read this register will return this pin value.
0	EN_GPIO11	Read/Write	Enable GPIO11 Function. Which enable multiple function pin 11, named TEMP_FAULT#/GPIO11, GPIO11 function. Set to 0 (default), pin 11 (TEMP_FAULT# /GPIO11) acts as TEMP_FAULT#. Set to 1, this pin 11 acts as GPIO11 control function and the output value of GPIO11 is programmed by this register bit 1.



7.11 GPIO1/2, GPIO7/8, and GPIO11/14/15/16 Output Control Register — Index 4Ah

Power on default [7:0] = 0000, 0000 b

BIT	NAME	READ/WRITE	DESCRIPTION
7	EN_GP16OUT	Read/Write	Enable GPIO16 (Pin 16) output function if set to 1. Otherwise, this pin serves as input. (Default is input)
6	EN_GP15OUT	Read/Write	Enable GPIO15 (Pin 15) output function if set to 1. Otherwise, this pin serves as input. (Default is input)
5	EN_GP14OUT	Read/Write	Enable GPIO14 (Pin 14) output function if set to 1. Otherwise, this pin serves as input. (Default is input)
4	EN_GP11OUT	Read/Write	Enable GPIO11 (Pin 11) output function if set to 1. Otherwise, this pin serves as input. (Default is input)
3	EN_GP8OUT	Read/Write	Enable GPIO8 (Pin 8) output function if set to 1. Otherwise, this pin serves as input. (Default is input)
2	EN_GP7OUT	Read/Write	Enable GPIO7 (Pin 7) output function if set to 1. Otherwise, this pin serves as input. (Default is input)
1	EN_GP2OUT	Read/Write	Enable GPIO2 (Pin 2) output function if set to 1. Otherwise, this pin serves as input. (Default is input)
0	EN_GP1OUT	Read/Write	Enable GPIO1 (Pin 1) output function if set to 1. Otherwise, this pin serves as input. (Default is input)

7.12 GPIO5, GPIO6, and GPIO13 Control Register — Index 4Bh

Power on default [7:0] = 0000, 0000 b

BIT	NAME	READ/WRITE	DESCRIPTION
6,7	Reserved	Read/Write	Reserved
5	EN_GP13OUT	Read/Write	Enable GPIO13 (Pin 13) output function if set to 1. Otherwise, this pin serves as input. (Default is input)
4	GPIO13_VAL	Read/Write	GPIO13 Output Value. GPIO13 output value if EN_GP13OUT is set to 1. Write 1, then pin 13 (GPIO13) always generate logic high signal. Write 0, pin 13 (GPIO13) always generates logic low signal. This bit default 0. Read will return this pin value
3	EN_GP6OUT	Read/Write	Enable GPIO6 (Pin 6) output function if set to 1. Otherwise, this pin serves as input. (Default is input)
2	GPIO6_VAL	Read/Write	GPIO6 Output Value. GPIO6 output value if EN_GP6OUT is set to 1. Write 1, then pin 6 (GPIO6) always generate logic high signal. Write 0, pin 6 (GPIO6) always generates logic low signal. This bit default 0. Read will return this pin value
1	EN_GP5OUT	Read/Write	Enable GPIO5 (Pin 5) output function if set to 1. Otherwise, this pin serves as input. (Default is input)
0	GPIO5_VAL	Read/Write	GPIO5 Output Value. GPIO5 output value if EN_GP5OUT is set to 1. Write 1, then pin 5 (GPIO5) always generate logic high signal. Write 0, pin 5 (GPIO5) always generates logic low signal. This bit default 0. Read will return this pin value



7.13 Winbond Vendor ID (Low Byte) — Index 4Ch

Power-on default [7:0] = 1010, 0011 b (A3h)

BIT	NAME	READ/WRITE	DESCRIPTION
7:0	VIDL[7:0]	Read Only	Vendor ID Low Byte. Default A3h.

7.14 Winbond Vendor ID (High Byte) — Index 4Dh

Power-on default [7:0] = 0101, 1100 b (5Ch)

BIT	NAME	READ/WRITE	DESCRIPTION
7:0	VIDH[7:0]	Read Only	Vendor ID High Byte. Default 5Ch

7.15 Chip ID — Index 4Eh

Power on default [7:0] = 0101, 0000 b

BIT	NAME	READ/WRITE	DESCRIPTION
7-0	CHIPID[7:0]	Read Only	Winbond Chip ID number. Read this register will return 60h for W83L785R.

7.16 Reserved — Index 4Fh

Reserved

7.17 OVT# Property Select — Index 50h

Power on default [7:0] = 0000, 0000 b

BIT	NAME	READ/WRITE	DESCRIPTION
7-5	Reserved	Read/Write	Reserved.
4	OVT_MD	Read/Write	<p>OVT# Mode Select. There are two OVT# signal output type.</p> <p><0> - Comparator Mode: (Default) Temperature exceeding T_O causes the OVT# output activated until the temperature is less than T_{HYST}.</p> <p><1> - Interrupt Mode: Setting temperature exceeding T_O causes the OVT# output activated indefinitely until reset reading temperature sensor 1/2 registers. Temperature exceeding T_O, then OVT# reset, and then temperature going below T_{HYST} will also cause the OVT# activated indefinitely until reset by reading temperature sensor 1/2. Once the OVT# will not be activated by exceeding T_O, then reset, if the temperature remains above T_{HYST}, the OVT# will not be active again.</p>



OVT# Property Select — Index 50h, continued.

BIT	NAME	READ/WRITE	DESCRIPTION
3	Reserved	Read/Write	Reserved
2	EN_OVT2	Read/Write	Enable temperature sensor 2 over-temperature (OVT) output if set to 1. Default 0, disable OVT2 output through pin OVT#. The pin OVT# is wire OR with OVT1. Default disable temperature 2 OVT# function.
1	EN_OVT1	Read/Write	Enable temperature sensor 1 over-temperature (OVT) output if set to 1. Default 0, disable OVT1 output through pin OVT#. The pin OVT# is wire OR with OVT2. Default disable temperature 1 OVT# function.
0	OVTPOL	Read/Write	Over-Temperature Polarity. Write 1, OVT# active high. Write 0, OVT# active low. Default 0.

7.18 SMI# Property Select — Index 51h

Power on - <7:0> --0000, 0100 b

BIT	NAME	READ/WRITE	DESCRIPTION
7-4	Reserved	Read/Write	Reserved.
3-2	TEMP_SMI_MD[1:0]	Read/Write	<p>Temperature SMI Mode Select.</p> <p><00> - Comparator Interrupt Mode: Temperature 1/2 exceeds T_O (Over-temperature) limit causes and interrupt and this interrupt will be reset by reading all the Interrupt Status.</p> <p><01> - Two Time Interrupt Mode:(Default) This bit use in temperature sensor 1/2 interrupt mode with hysteresis and T_O type. Temperature exceeding T_O, causes an interrupt and then temperature going below T_{HYST} will also cause another interrupt if the previous interrupt has been reset by reading all the interrupt Status Register. Once an interrupt event has occurred by exceeding T_O, then reset, if the temperature remains above the T_{HYST}.</p> <p><10> - One Time Interrupt Mode: This bit use in temperature sensor 1/2 interrupt mode with hysteresis type. Temperature exceeding T_O (Over-temperature) causes an interrupt and then temperature going below T_{HYST} (Hysteresis temperature) will not cause an interrupt. Once an interrupt event has occurred by exceeding T_O, then going below T_{HYST}, and interrupt will not occur again until the temperature exceeding T_O.</p>
1	EN_SMI#	Read/Write	Enable SMI# Output. A one enables the SMI# Interrupt output.
0	SMIPOL	Read/Write	SMI# Polarity. Write 1, SMI# active high. Write 0, SMI# active low. Default 0.



7.19 Thermal Sensor 1/2 Type Register — Index 52h

Power on default [7:0] = 0000, 0000 b

BIT	NAME	READ/WRITE	DESCRIPTION
7-4	Reserved	Read/Write	Reserved.
3-2	T2_TYPE[1:0]	Read/Write	Temperature sensor 2 (CPU) type. 0x - Thermistor (10K @ 25 degree C, B=3435). 11 - Intel thermal diode.
1-0	T1_TYPE[1:0]	Read/Write	Temperature sensor 2 (environment) types. 0x - Thermistor (10K @ 25 degree C, B=3435) 11 - Intel thermal diode.

7.20 Temperature Sensor 1 Fault Limit — Index 53h

Power on default [7:0] = 0111, 1111 b

BIT	NAME	READ/WRITE	DESCRIPTION
7-0	TEMP1_LM	Read/Write	Temperature sensor 1 Limit Value.

7.21 Temperature Sensor 2 Fault Limit — Index 54h

Power on default [7:0] = 0111, 1111 b

BIT	NAME	READ/WRITE	DESCRIPTION
7-0	TEMP2_LM	Read/Write	Temperature sensor 2 Limit Value.

7.22 Reserved — Index 55h ~ 7Fh

Reserved



7.23 PWM 1 Pre-Scale Register — Index 80h

Power on default [7:0] = 0000, 0001 b

BIT	NAME	READ/WRITE	DESCRIPTION
7	PWM_CLK_SEL1	Read/Write	PWM 1 Input Clock Select. This bit select PWM 1 input clock. 0: 1 MHz 1: 125 KHz
6-0	PRE_SCALE1[6:0]	Read/Write	PWM 1 Input Clock Pre-Scale. The divider of input clock is the number defined by pre-scale. Thus, writing 0 transfers the input clock directly to counter. The maximum divider is 128 (7Fh). 00h : divider is bypass 01h : divider is 1 02h : divider is 2 : :

PWM output frequency is (Pre-scale frequency) / 256 .

For example, if setting this register 81h, the pin FANOUT0 output frequency = $\frac{125\text{KHz}}{256} = 488 \text{ Hz}$

7.24 PWM 1 Duty Cycle Select Register — 81h

Power on default [7:0] 1111, 1111 b

BIT	NAME	READ/WRITE	DESCRIPTION
7-0	PWM1_DC[7:0]	Read/Write	PWM 1 Duty Cycle. This 8-bit register determines the number of input clock cycles, out of 256-cycle period, during which the PWM output is high. 00h: PWM output is always logical Low. FFh: PWM output is always logical High. XXh: PWM output logical High percentage is (XX/256*100%) during one cycle.



7.25 PWM 2 Pre-Scale Register — Index 82h

Power on default [7:0] = 0000, 0001 b

BIT	NAME	READ/WRITE	DESCRIPTION
7	PWM_CLK_SEL2	Read/Write	PWM 2 Input Clock Select. This bit select PWM 2 input clock. 0: 1 MHz 1: 125 KHz
6-0	PRE_SCALE2[6:0]	Read/Write	PWM 2 Input Clock Pre-Scale. The divider of input clock is the number defined by pre-scale. Thus, writing 0 transfers the input clock directly to counter. The maximum divider is 128 (7Fh). 00h : divider is 1 01h : divider is 2 02h : divider is 3 : :

7.26 PWM2 Duty Cycle Select Register — Index 83h

Power on default [7:0] = 1111, 1111 b

BIT	NAME	READ/WRITE	DESCRIPTION
7-0	PWM2_DC[7:0]	Read/Write	PWM 2 Duty Cycle. This 8-bit register determines the number of input clock cycles, out of 256-cycle period, during which the PWM output is high. 00h: PWM output is always logical Low. FFh: PWM output is always logical High. XXh: PWM output logical High percentage is $XX/256*100\%$ during one cycle.

7.27 Reserved Register — Index 84h

Power on default [7:0] = 0000, 0000 b



7.28 Temperature Sensor 1 (for Environment) Offset Register — Index 85h

Power-on default [7:0] = 0000, 0000 b

BIT	NAME	READ/WRITE	DESCRIPTION
7-0	OFFSET1[7:0]	Read/Write	Temperature 1 base temperature. The temperature is added by both monitor value and offset value. 0111,1111 => +127 degree C 0111,1110 => +126 degree C : 0000,0001 => +1 degree C 0000,0000 => +0 degree C 1111,1111 => -1 degree C 1111,1110 => -2 degree C : 1000,0000 => -128 degree

7.29 Temperature Sensor 2 (for CPU) Offset Register — Index 86h

Power-on default [7:0] = 0000, 0000 b

BIT	NAME	READ/WRITE	DESCRIPTION
7-0	OFFSET2[7:0]	Read/Write	Temperature 2 base temperature. The temperature is added by both monitor value and offset value. 0111,1111 => +127 degree C 0111,1110 => +126 degree C : 0000,0001 => +1 degree C 0000,0000 => +0 degree C 1111,1111 => -1 degree C 1111,1110 => -2 degree C : 1000,0000 => -128 degree



8. VALUE RAM AND LIMIT VALUE

8.1 Value RAM — Index 20h- 3Fh or 60h - 7Fh

INDEX A7-A0	DESCRIPTION
20h	VCORE reading
21h	+2.5V reading
22h	+1.5V reading
23h	VCC reading (internal divisor 3)
24h	Reserved
25h	Reserved
26h	Temperature 2 reading
27h	Temperature 1 reading
28h	FAN1 reading Note: This location stores the number of counts of the internal clock per revolution.
29h	FAN2 reading Note: This location stores the number of counts of the internal clock per revolution.
2Ah	Reserved
2Bh	VCORE High Limit. (0xff)
2Ch	VCORE Low Limit. (0x00)
2Dh	+2.5V High Limit. (0xff)
2Eh	+2.5V Low Limit. (0x00)
2Fh	+1.5V High Limit. (0xff)
30h	+1.5V Low Limit. (0x00)
31h	VCC High Limit. (0xff)
32h	VCC Low Limit. (0x00)
33h	Reserved
34h	Reserved
35h	Reserved
36h	Reserved
37h	Over Temperature 2 Limit (High). (0x50)
38h	Temperature 2 Hysteresis Limit (Low). (0x4b)
39h	Over Temperature 1 Limit (High). (0x50)
3Ah	Temperature 1 Hysteresis Limit (Low). (0x4b)
3Bh	FAN1 Fan Count Limit. (0xff) Note: It is the number of counts of the internal clock for the Low Limit of the fan speed.
3Ch	FAN2 Fan Count Limit. (0xff) Note: It is the number of counts of the internal clock for the Low Limit of the fan speed.
3Dh	Reserved
3E- 3Fh	Reserved



9. SPECIFICATIONS

9.1 Absolute Maximum Ratings

PARAMETER	RATING	UNIT
Power Supply Voltage	-0.5 to 7.0	V
Input Voltage	-0.5 to V _{CC} +0.5	V
Operating Temperature	0 to +70	°C
Storage Temperature	-55 to +150	°C

Note: Exposure to conditions beyond those listed under Absolute Maximum Ratings may adversely affect the life and reliability of the device.

9.2 DC Characteristics

(T_a = 0° C to 70° C, V_{DD} = 5V ± 10%, V_{SS} = 0V)

PARAMETER	SYM.	MIN.	TYP.	MAX.	UNIT	CONDITIONS
I/O_{12t} - TTL level bi-directional pin with source-sink capability of 12 mA						
Input Low Voltage	V _{IL}			0.8	V	
Input High Voltage	V _{IH}	2.0			V	
Output Low Voltage	V _{OL}			0.4	V	I _{OL} = 12 mA
Output High Voltage	V _{OH}	2.4			V	I _{OH} = - 12 mA
Input High Leakage	I _{LIH}			+10	μA	V _{IN} = V _{DD}
Input Low Leakage	I _{LIL}			-10	μA	V _{IN} = 0V
I/O_{12ts} - TTL level bi-directional pin with source-sink capability of 12 mA and schmitt-trigger level input						
Input Low Threshold Voltage	V _{t-}	0.5	0.8	1.1	V	V _{DD} = 5 V
Input High Threshold Voltage	V _{t+}	1.6	2.0	2.4	V	V _{DD} = 5 V
Hysteresis	V _{TH}	0.5	1.2		V	V _{DD} = 5 V
Output Low Voltage	V _{OL}			0.4	V	I _{OL} = 12 mA
Output High Voltage	V _{OH}	2.4			V	I _{OH} = - 12 mA
Input High Leakage	I _{LIH}			+10	μA	V _{IN} = V _{DD}
Input Low Leakage	I _{LIL}			-10	μA	V _{IN} = 0V
OUT_{12t} - TTL level output pin with source-sink capability of 12 mA						
Output Low Voltage	V _{OL}			0.4	V	I _{OL} = 12 mA
Output High Voltage	V _{OH}	2.4			V	I _{OH} = -12 mA
OD₈ - Open-drain output pin with sink capability of 8 mA						
Output Low Voltage	V _{OL}			0.4	V	I _{OL} = 8 mA



DC Characteristics, continued

PARAMETER	SYM	MIN.	TYP.	MAX.	UNIT	CONDITIONS
OD₁₂ - Open-drain output pin with sink capability of 12 mA						
Output Low Voltage	VOL			0.4	V	IOL = 12 mA
OD₄₈ - Open-drain output pin with sink capability of 48 mA						
Output Low Voltage	VOL			0.4	V	IOL = 48 mA
IN_t - TTL level input pin						
Input Low Voltage	VIL			0.8	V	
Input High Voltage	VIH	2.0			V	
Input High Leakage	IIH			+10	μA	VIN = VDD
Input Low Leakage	ILIL			-10	μA	VIN = 0 V
IN_{ts} - TTL level Schmitt-triggered input pin						
Input Low Threshold Voltage	Vt-	0.5	0.8	1.1	V	VCC = 5 V
Input High Threshold Voltage	Vt+	1.6	2.0	2.4	V	VCC = 5 V
Hysteresis	VTH	0.5	1.2		V	VCC = 5 V
Input High Leakage	IIH			+10	μA	VIN = VCC
Input Low Leakage	ILIL			-10	μA	VIN = 0 V

9.3 AC Characteristics

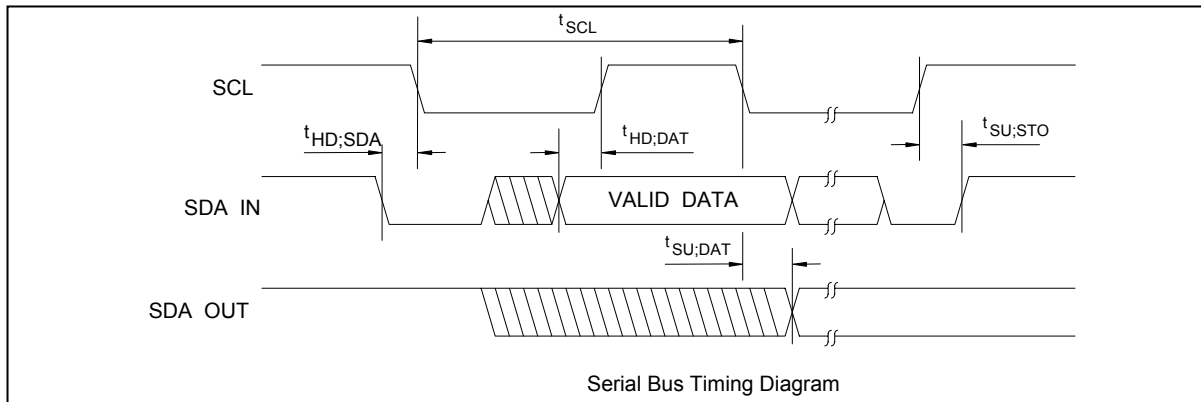

Serial Bus Timing

PARAMETER	SYMBOL	MIN.	MAX.	UNIT
SCL clock period	t_{SCL}	10		μS
Start condition hold time	$t_{HD;SDA}$	4.7		μS
Stop condition setup-up time	$t_{SU;STO}$	4.7		μS
DATA to SCL setup time	$t_{SU;DAT}$	120		nS
DATA to SCL hold time	$t_{HD;DAT}$	5		nS
SCL and SDA rise time	t_R		1.0	μS
SCL and SDA fall time	t_F		300	nS



10. HOW TO READ THE TOP MARKING

The top marking of W83L785R



Left: Winbond logo

1st line: Type number W83L785R, R means SSOP (Thickness = 209mil).

2nd line: Tracking code 2 826978Y

2: wafers manufactured in Winbond FAB 2

826978Y: wafer production series lot number

3rd line: Tracking code 046 A A

046: packages made in 2000, week 46

Q: assembly house ID; A means ASE, O means OSE, G means Greatek

A: IC revision; A means version A, B means version B

The top marking of W83L785R



Left: Winbond logo

1st line: Type number W83L785G, G means Lead-free package.

2nd line: Tracking code 2 826978Y

2: wafers manufactured in Winbond FAB 2

826978Y: wafer production series lot number

3rd line: Tracking code 046 A A

046: packages made in 2000, week 46

Q: assembly house ID; A means ASE, O means OSE, G means Greatek

A: IC revision; A means version A, B means version B

11. PACKAGE DRAWING AND DIMENSIONS

20 SSOP-209 mil

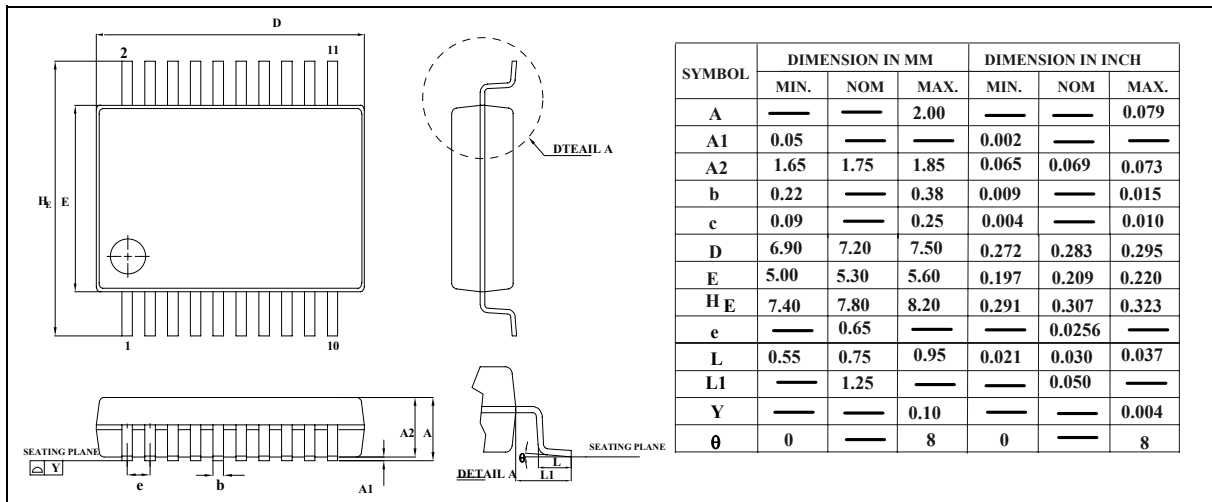

12. W83L785R SCHEMATICS

Rev.
 0.1:W83L785R application circuit. VCC=3.3V
 0.2:R29 30K change to 15K
 0.3:R44,R45,R46 1K change to 4.7K

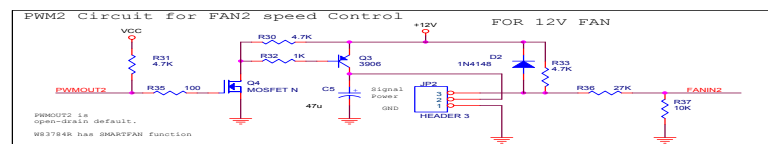
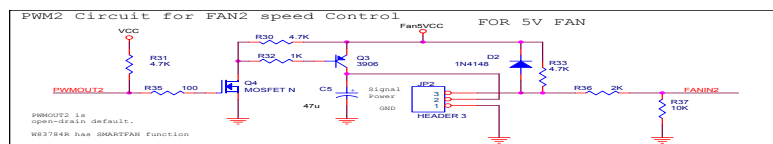
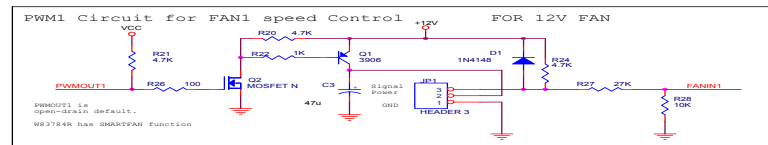
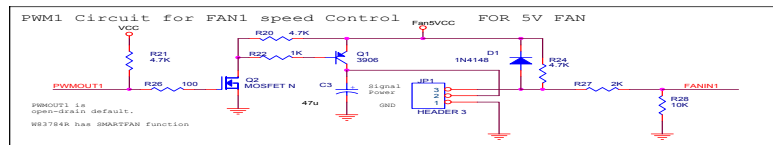
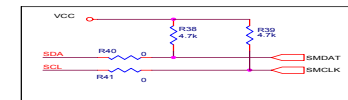
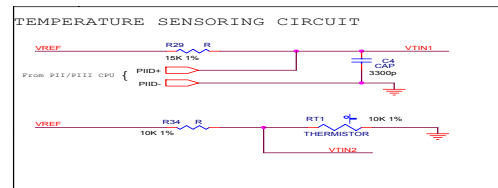
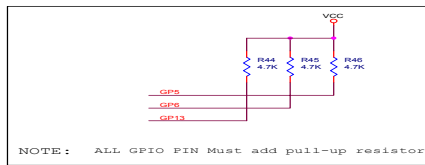
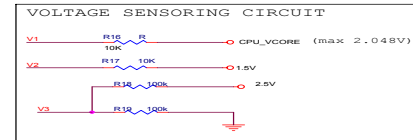
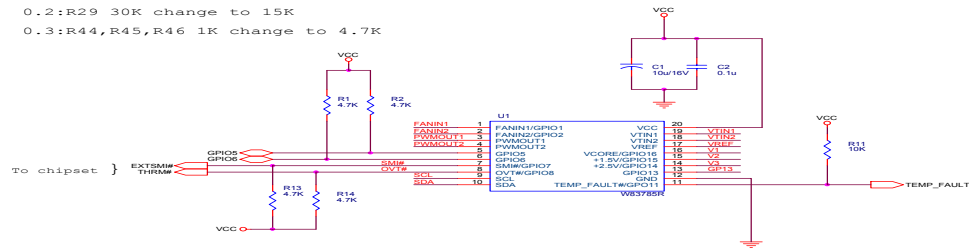

WINBOND ELECTRONICS CORP.	
Title: W83L785R Application Circuit	
Size: 11.5x16.5	Rev: 0.3
Doc#: 785R SCh	
Date: Monday, July 02, 2001	Printed: 1 of 1



Please note that all data and specifications are subject to change without notice. All the trade marks of products and companies mentioned in this data sheet belong to their respective owners.

These products are not designed for use in life support appliances, devices, or systems where malfunction of these products can reasonably be expected to result in personal injury. Winbond customers using or selling these products for use in such applications do so at their own risk and agree to fully indemnify Winbond for any damages resulting from such improper use or sale.

Important Notice

Winbond products are not designed, intended, authorized or warranted for use as components in systems or equipment intended for surgical implantation, atomic energy control instruments, airplane or spaceship instruments, transportation instruments, traffic signal instruments, combustion control instruments, or for other applications intended to support or sustain life. Further more, Winbond products are not intended for applications wherein failure of Winbond products could result or lead to a situation wherein personal injury, death or severe property or environmental damage could occur.

Winbond customers using or selling these products for use in such applications do so at their own risk and agree to fully indemnify Winbond for any damages resulting from such improper use or sales.



Headquarters

No. 4, Creation Rd. III,
Science-Based Industrial Park,
Hsinchu, Taiwan
TEL: 886-3-5770066
FAX: 886-3-5665577
<http://www.winbond.com.tw/>

Taipei Office

9F, No.480, Rueiguang Rd.,
Neihu District, Taipei, 114,
Taiwan, R.O.C.
TEL: 886-2-8177-7168
FAX: 886-2-8751-3579

Winbond Electronics Corporation America

2727 North First Street, San Jose,
CA 95134, U.S.A.
TEL: 1-408-9436666
FAX: 1-408-5441798

Winbond Electronics Corporation Japan

7F Daini-ueno BLDG, 3-7-18
Shinyokohama Kohoku-ku,
Yokohama, 222-0033
TEL: 81-45-4781881
FAX: 81-45-4781800

Winbond Electronics (Shanghai) Ltd.

27F, 2299 Yan An W. Rd. Shanghai,
200336 China
TEL: 86-21-62365999
FAX: 86-21-62365998

Winbond Electronics (H.K.) Ltd.

Unit 9-15, 22F, Millennium City,
No. 378 Kwun Tong Rd.,
Kowloon, Hong Kong
TEL: 852-27513100
FAX: 852-27552064

*Please note that all data and specifications are subject to change without notice.
All the trade marks of products and companies mentioned in this data sheet belong to their respective owners.*