

Compact 1200 bps Modem

Description

The XE1276A is the successor to the XE1276. Several improvements have been incorporated in the XE1276A. Power consumption has been reduced, an automatic Sleep mode has been added and the XE1276A includes non-volatile memory for storage of the "AT" Commands used for modem control and configuration.

The XE1276A provides a replacement for the CH1776. Most OEM's currently using the CH1776 can use the XE1276A without altering their existing hardware or software. The XE2476 provides a 2400 bps upgrade in the same package design.

The XE1276A includes user transferable FCC Part 68 registration. This permits use of the XE1276A without additional FCC Part 68 testing.

Features

- Modem Protocols Supported: V.22, V.21, Bell 212A and 103
- Pin compatible with the XE1276, XE2476 and CH1776
- Command set: "AT" command set for modem control and configuration.
- Modem Configuration stored in NVRAM
- Small Size: 2.00 inches long, 1.125 inches wide, 0.44 inches high.
- Single +5V supply
- Low power CMOS:
Operating: 200 mW (Typical)
Sleep: 50 mW (maximum)

Block Diagram

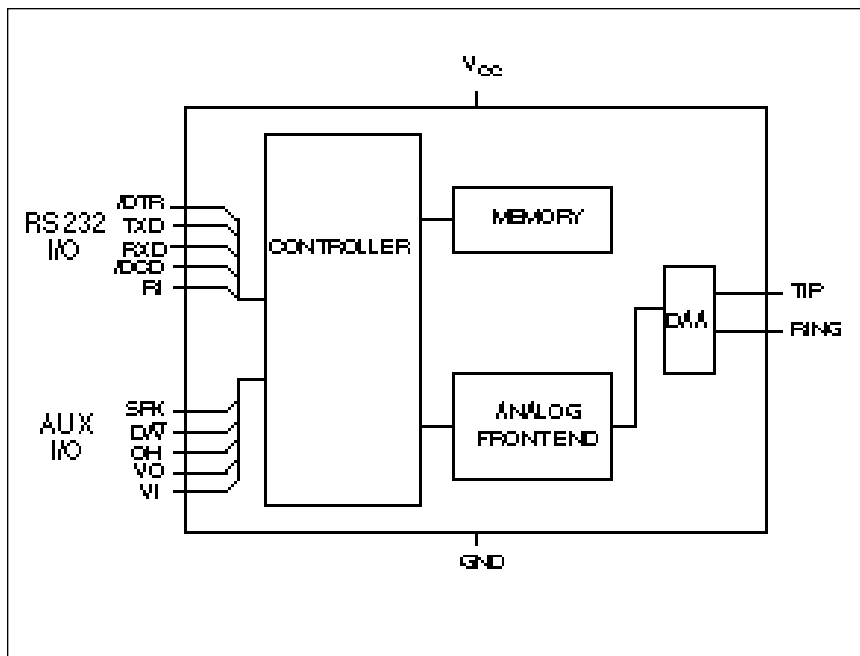

PIN CONFIGURATION

Pin	Signal	Pin	Signal
1	TST	18	RI
2	N/C	17	GND
3	N/C	16	VCC
4	/DCD		
5	/DTR		
6	D/V		
7	OHO		
8	RXD		
9	TXD		
10	N/C		
11	SPK		
12	VO		
13	VI		
		15	RING
		14	TIP

XE1276A
(Top View)

XE1276A Mechanical Specifications

PIN	INCHES		METRIC(MM)	
	MIN	MAX	MIN	MAX
A	1.990	2.010	50.55	51.05
B	1.115	1.135	28.32	28.83
C	0.420	0.430	10.67	10.92
D	0.100	0.120	2.54	3.05
E	0.890	0.910	22.61	23.11
F	0.090	0.110	2.29	2.79
G	0.090	0.110	2.29	2.79
H	0.190	0.210	4.83	5.33
I	0.020	0.025	0.51	0.64
J	0.125	0.200	3.18	5.08

Pins = 0.025 square pin
recommended hole size 0.056"

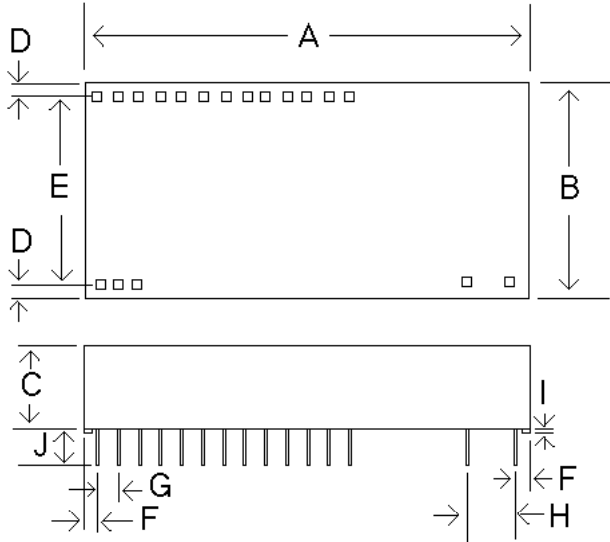

ABSOLUTE MAXIMUM RATINGS*

SUPPLY VOLTAGE - Vcc	+6.5 Volts
DC INPUT VOLTAGE	-0.6 Volts to +6.5 Volts
STORAGE TEMPERATURE RANGE	-25° C TO +100° C
LEAD TEMPERATURE (Soldering, 2 sec per wave)	260° C
OPERATING TEMPERATURE RANGE	0 TO 70° C
*Exceeding these values may result in permanent damage to the device.	

Power Supply Characteristics (TA = 0 - 70°C, Vcc = 5v ±5%)

Symbol	Parameter	Min	Typ	Max	Units	Comments
Vcc	Supply Voltage	4.75	5.0	5.25	V	
Icc	Vcc Supply Current		40	50	mA	On-Line All outputs Disconnected
Icc	Vcc Supply Current		7	10	mA	Sleep Mode

Sleep Mode: The XE1276A has an integrated, advanced power management capability. If no activity is detected on the RXD, DTR, or RI lines the modem will automatically go into a smart power down mode. In this mode power consumption is less than 50 milliwatts.

Pin Descriptions

PIN	NAME	DESCRIPTION
1	TST	This output is for Xecom test purposes only;
2	N/C	No Connection
3	N/C	No Connection
4	\DCD	DCD, Data Carrier Detect, is an active low output from the modem. DCD goes low to indicate receipt of a valid carrier signal.
5	\DTR	DTR, Data Terminal Ready, is an active low input to the modem. DTR must be present for the XE1276A to remain on line. If DTR goes high while the modem is on line, the modem disconnects immediately. The XE1276A will not automatically answer an incoming call if DTR is not active.
6	D/V	The D/V, Data/Voice, output can be used to drive a relay to connect an auxiliary telephone handset. D/V is high when the modem is off-hook And low when the modem is on-hook.
7	OH	OH, Off-Hook, is an active high output which indicates that the XE1276A is connected to the telephone line.
8	RXD	RXD, Received Data, provides the serial data output path from the modem. A logic "high" represents a "mark" and a logic "low" represents a "space".
9	TXD	TXD, Transmit Data, provides the serial data input path from the host. A logic "high" represents a "mark" and a low represents a "space", TTL.
10	N/C	No Connection
11	SPK	SPK, Speaker, provides the Audio output to the modem speaker. Speaker operation is determined by the ATL and ATMM commands . This output can drive a 300 ohm load.
12	VO	The Modem Line Interface permits placement of non-modem signals on the telephone line through the modem's telephone interface. VO must be tied to VI for normal modem operation and open to place non-modem signals on the line through VI.
13	VI	VI, Voice Interface, provides a path for non-modem signals to be placed on the telephone line through the modem's telephone interface. VI must be tied to VO for modem operation.
14	TIP	Tip connection to the phone line(RJ11 pin3) from the internal DAA.
15	RING	Ring connection to the phone line(RJ11 pin4) from the internal DAA.
16	Vcc	+5 Volt power for the modem.
17	GND	Ground reference for the modem.
18	RI	RI, Ring Indicator, provides an active high output whenever a ring signal appears on the telephone line.

AT Commands

The XE1276A uses "AT" commands for modem configuration. This section describes the command format and lists the commands, registers and result codes.

Modes of Operation

The "AT" commands have two operational modes; Command Mode and Data Mode.

Data Mode: The XE1276A enters data mode upon connecting with a remote modem and issues an appropriate "CONNECT" result code. In Data Mode the modem sends all data presented on Transmit Data (TXD) to the remote modem and places demodulated data from the remote modem onto Received Data (RXD). When the modem exits data mode, it issues the "NO CARRIER" result code.

Command Mode: The XE1276A enters command mode on power-up, reset, a lost connection, or receipt of the escape code. In command mode the modem accepts commands from the host on transmit data. Appropriate result codes are returned on received data.

Command Line Format

Command lines issued to the modem follow a strict format. Each command begins with the prefix AT. The command line is stored in the command buffer and executed upon receipt of a carriage return. Until executed, the command line can be edited with the backspace key.

Command Prefix - Commands, except A/, begin with the AT prefix. The "A" and "T" may be both upper case or both lower case but cannot be of different cases. The prefix identifies the speed and parity of the commands sent by the host. Speed is determined by measuring the width of the incoming bits. Parity is determined by comparing the parity bits of the "A" and "T."

Command Line - Commands may be strung together in a single command line of up to 40 characters. Commands are executed in the sequence they appear. A carriage return terminates the command line and causes the commands to be executed. Register S3 allows the user to select a character other than a carriage return to terminate the command line.

Command Buffer - The command buffer stores up to 40 characters, including the AT prefix, from one command line. Spaces may be inserted into the command line without filling space in the command buffer. If the command buffer overflows, the modem issues an "ERROR" result code and commands are not executed.

Command Line Editing - A backspace can be used to edit a command line before execution. The backspace key, (Control and H simultaneously on some systems), erases the previous character in the command line. Register S5 allows the user to select a character other than a backspace as the command line editor.

Re-Execute Last Command - The A/ command causes the modem to reexecute the last command line. This command does not require the "AT" prefix.

Omitted Parameters - Most commands include a parameter which determine the function setting. When the command parameter is omitted from the command string, it is assumed to be a 0.

Escape Characters - An escape sequence may be entered while in data mode to switch the modem into command mode while on line. The escape character, set by Register S2, must be entered 3 times in succession within a 1 second guard time to execute the escape. The default escape sequence is "+++."

Result Codes - The modem issues a result code after each action. Result codes may be provided as full words, numeric codes or may be disabled all together. Each result code ends with a carriage return when numeric result codes are chosen. When full word result codes are chosen, a Line feed and Carriage Return precede and follow each result code.

XE1276A AT Command List

A - Answer Command -

Bn - Select Communications Standard

- n=0 Selects CCITT standards
- n=1 Selects Bell standards*

D - Dial Command -

- P = Pulse dial
- T = Tone dial
- R = Connect as an answering modem
- W = Wait for dial tone
- , = Pause for the duration of S8
- @ = Wait for silence
- ! = Switch hook flash
- ; = Return to the command state
- Sn = Dial number stored in location n

En - Command Echo

- n=0 Do not echo commands
- n=1 Enable command echo*

Hn - Switch Hook Control -

- n=0 Switch hook relay closes*
- n=1 The switch hook relay opens

In - Modem Identification

Ln - Speaker Volume -

- n=0 Low speaker volume
- n=1 Low speaker volume
- n=2 Moderate speaker volume*
- n=3 High speaker volume

Mn - Speaker Activity -

- n=0 Speaker off
- n=1 Speaker on until carrier received*
- n=2 Speaker remains on
- n=3 Speaker on after dialing until carrier detected.

On - On Line

- n=0 Return On Line with no retrain*
- n=1 No response to remote test request.
- n=2 Initiate Remote Digital Loopback

Qn - Responses

- n=0 Send responses *
- n=1 No Responses

Sr? - Interrogate Register -

Sr=n - Set Register Value -

Vn - Result Codes -

- n=0 Numeric Result Codes
- n=1 English Word Result Codes*

Xn - Result Code Set -

- n=0 Responses 0-4*
- n=1 Responses 0-5
- n=2 Responses 0-6
- n=3 Responses 0-5, & 7
- n=4 Responses 0-8

Z - Reset -

&Cn - DCD Operation

- n=0 DCD is forced active
- n=1 DCD indicates a valid carrier signal*

&Dn - DTR

- n=0 DTR is ignored by the modem
- n=2 Modem disconnects if DTR revoked.*
- n=3 The modem performs a soft reset when DTR is revoked.

&F - Use XE2476 Defaults

&Tn - Test Modes

- n=0 Exit test mode
- n=1 Local analog loopback
- n=3 Initiate local digital loopback
- n=4 Respond to remote loop request*
- n=5 Deny remote loop request
- n=6 Initiate a Remote Digital loopback
- n=7 Remote digital loopback w self-test
- n=8 Local analog loopback w self-test

&V - View Active Profile -

&Wn - Store Profile -

- n=0 Stores the current configuration in memory location 0.
- n=1 Stores the current configuration in memory location 1.

&Yn - Recall Profile

- n=0 Use memory location 0.
- n=1 Use memory location 1.

&Zn=X- Store Number

* Indicates the default setting for the command as shipped by Xecom.

XE1276A S-Register Summary

REG.	RANGE/UNITS	DESCRIPTION	DEFAULT
S0	0-255/rings	Number of rings to answer on	001
S1	0-255/rings	Count number of incoming rings	000
S2	0-127/ASCII	Escape character	043
S3	0-127/ASCII	Carriage return character	013
S4	0-127/ASCII	Line feed character	010
S5	0-32,127/ASCII	Backspace character	008
S6	2-255/sec	Dial tone wait time	002
S7	1-60/sec	Wait time for remote carrier	030
S8	0-255/sec	Comma pause time	002
S9	1-255/0.1 sec	Carrier detect response time	006
S10	1-255/0.1 sec	Delay from loss of carrier to hang up	014
S14	Bit Mapped	E,Q,V,T,P,D,A,R accept/ignore	170
S16	Bit Mapped	Modem loopback tests	000
S18	0-255/sec	Modem test timer	000
S21	Bit Mapped	J, &D, &C, Y	000
S22	Bit Mapped	L, M, X, &T4, &T5, DTE speed and parity	118
S23	Bit Mapped	&T4,&T5, DTE speed, parity	007
S27	Bit Mapped	&X, B commands	064

Result Code Summary

DIGIT	CODE	WORD CODE MEANING
0	OK	Successfully executed command line
1	CONNECT	300 bps connection established
2	RING	Ring signal detected
3	NO CARRIER	Carrier not detected within Register S7 detect time
4	ERROR	Error found in command line; returns to command line
5	CONNECT 1200	1200 bps connection established
6	NO DIAL TONE	No dial tone detected within 5 Sec. after going off-hook
7	BUSY	Busy signal detected after automatically dialing a call
8	NO ANSWER	Five seconds of silence was not detected when using the @ command in the Dial command line

XE1276A Electrical Specifications

Parameter	Min	Typ	Max	Unit	Comments
DTMF Level		-2.2	0	dBm	3 second average
Modem Transmit Level	-12	-10.5	-9.0	dBm	600 ohm line
Pulse Dialing Rate			10	pps	
Pulse Dialing Make/Break		39/61		%	USA
Billing Delay Interval	2.0			sec.	
Phone Line Impedance Match		600		ohms	
Ring Detect Sensitivity	38		150	VRMS	Type B Ringer
Telephone Loop Current	20		100	milliamps	Off-hook
Input High Voltage (TXD, DTR)	2.0			Volts	
Input Low Voltage (TXD, DTR)			0.8	Volts	
Output High Voltage (DCD, RXD, RI, OH)	2.4			Volts	RXD -100 microamps; DCD, RI, OH - 1.6 mamps
Output Low Voltage (DCD, RXD, RI, OH)			0.4	Volts	RXD - 1.6 milliamps; DCD, RI, OH - 6 milliamps
Output Drive Current (OH, D/V)			10	milliamps	

FCC Part 68 Information

Registration Number - DWEUSA-21473-MD-E

Ringer Equivalence - 0.8B

XE1276A Applications Schematic

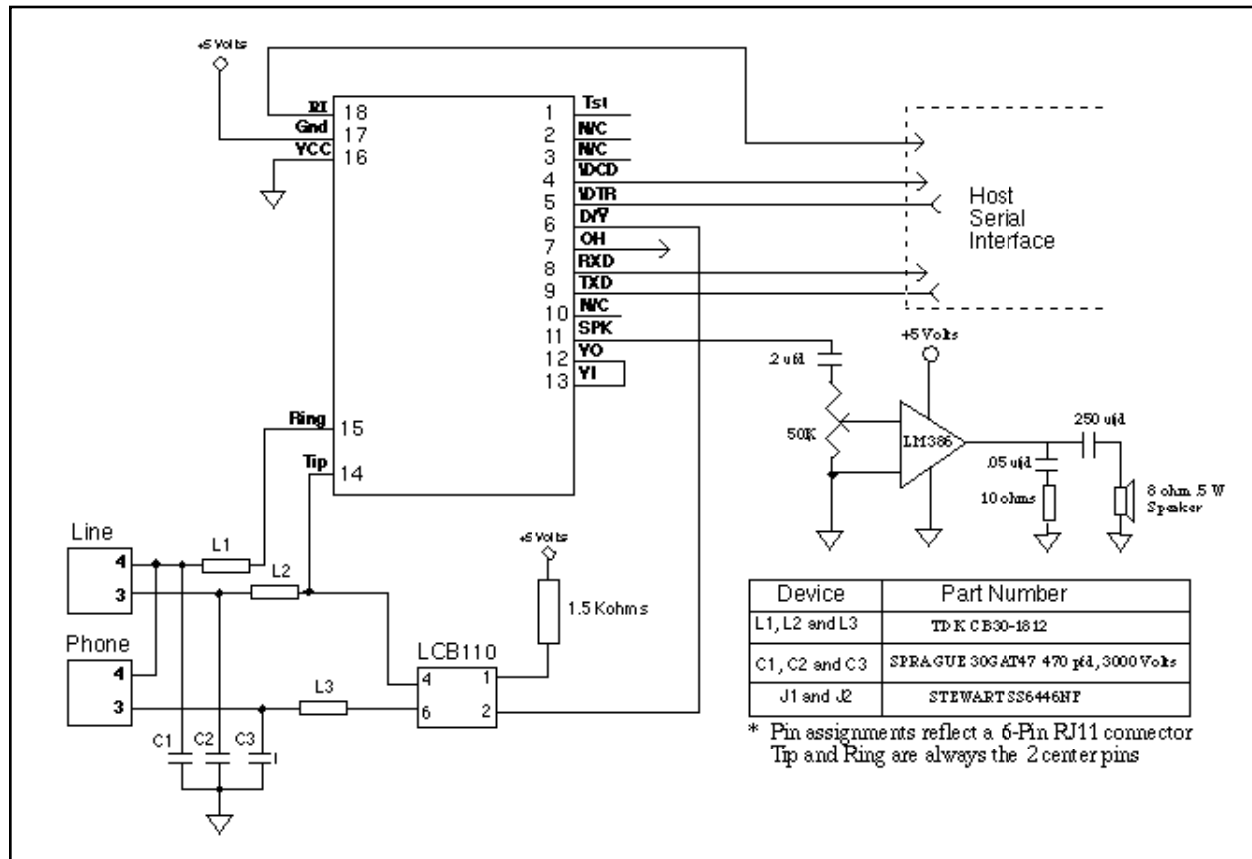

Differences between the XE1276A and XE1276

In creating the XE1276A Xecom strived to make the new product compatible with both the XE1276 and XE2476. Unfortunately some features could not be supported in the new product. We believe the improvements made will benefit most XE1276 customers.

New Features: The XE1276A features reduced power consumption and the addition of non-volatile memory for modem configuration storage.

We reduced XE1276A power consumption in two ways. First, we reduced operating power by 20% using new low power components. Second, we added a sleep mode. The XE1276A automatically enters sleep mode if there is no activity for 5 seconds. In sleep mode power consumption is reduced to less than 50 milliWatts.

The addition of non-volatile memory permits the user to configure the modem once and never configure it again. It also permits storage of up to four telephone numbers which can be recalled for dialing.

Unsupported XE1276 Features: The features lost in the XE1276A redesign were the specialized interface pins for Auto-answer, Command Mode, and Speed Indication. The XE1276A does not support High-Speed Indication on Pin 1, Command Mode Indication on Pin 2, or Auto Answer Disabled on pin 3. Please contact Xecom's Application Engineering Department to assist in working around these lost features.

FCC Instructions

This product complies with part 68 of the FCC Rules and Regulations. With each device shipped, there is a label which contains, among other information, the FCC Registration Number and Ringer Equivalence Number (REN) for this product. You must, upon request, provide this information to your telephone company.

The mounting of this device in the final assembly must be made in such a manner as to preserve the high voltage protection between the TIP/RING Connection and the rest of the system. Typically, this may be accomplished by maintaining a minimum spacing .100 mils between the TIP/RING Traces to the RJ-11C Jack and low voltage portion of the system. No additional circuitry may be attached between TIP/RING and the telephone line connection, unless specifically allowed in the rules.

The REN is useful to determine the quantity of devices you may connect to a telephone line and still have all of these devices ring when the number is called. In most, but not all areas, the sum of the RENs of all devices connected to one line should not exceed five (5.0). To be certain of the number of devices you may connect to the line, as determined by the REN, you should contact the local telephone company to determine the maximum REN for your calling area.

If your system causes harm to the telephone network, the telephone company may discontinue service temporarily. If possible, they will notify you in advance. If advance notification is not practical, you will be notified as soon as possible.

Your telephone company may make changes in its facilities, equipment, operations or procedures that could affect proper functioning of your equipment. If they do, you will be notified in advance to give you an opportunity to maintain uninterrupted telephone service.

If you experience trouble with this device, please contact XECOM at (408) 945-6640 for information on obtaining service or repairs. The telephone company may ask you to disconnect this device from the network until the problem has been corrected or until you are sure that the device is not malfunctioning.

The device may not be used on coin service lines provided by the telephone company (this does not apply to private coin telephone applications which use standard telephone lines). Connection to party lines is subject to state tariffs.

Terms of Sale

Devices sold by XECOM are covered by the warranty provisions appearing in its Terms of Sale only. XECOM makes no warranty, express, statutory, implied, or by description regarding the information set forth herein, or regarding the freedom of the described devices from patent infringement. XECOM makes no warranty of merchantability or fitness for any purposes. XECOM reserves the right to discontinue production and change specifications and prices at any time and without notice. This product is intended for use in normal commercial applications. Applications requiring extended temperature range, unusual environmental requirements, or high reliability applications, such as military, medical life-support or life-sustaining equipment, are specifically not recommended without additional processing and authorization by XECOM for such application.

Xecom assumes no responsibility for the use of any circuitry other than circuitry embodied in a Xecom product. No other circuits, patents, or licenses are implied.

Life Support Policy

Xecom's products are not authorized for use as Critical Components in Life Support Devices or Systems.

Life Support Devices or Systems are devices or systems which, (a) are intended for surgical implant into the body, or (b) support or sustain life, and whose failure to perform, when properly used in accordance with instructions provided in the labeling, can be reasonably expected to result in significant injury to the user.

A Critical Component is any component of a life support device or system whose failure to perform can be reasonably expected to cause failure of the life support device or system, or to affect its safety or effectiveness.

Copyright, Xecom © 1997

While Xecom, Inc. has made every effort to ensure that the information presented here is accurate, Xecom will not be liable for any damages arising from errors or omission of fact. Xecom reserves the right to modify specifications and/or prices without notice. Product mentioned herein are used for identification purposes only and may be trademarks and/or registered trademarks of their respective companies.



Xecom Incorporated
374 Turquoise Street, Milpitas, CA 95035
Ph:408-945-6640 Fax:408-942-1346
<http://www.xecom.com/xecom>