

RKT102***MH

μ-Chip (RFID)

REJ03P0007-0100
Rev.1.00
Feb 23, 2007

Overview

- RKT102***MH is RFID (Radio Frequency Identification) for 2.45 GHz.
- It has a unique ID inside, then it is applicable for management of individual object.

Feature

- Thin and small package: COA (Chip on Aluminum)
- Including unique μ-Chip ID which is not alterable
- Including a unique ID
- Communication without contact
- Including a congestion control function

Note: "μ-Chip" and the μ-Chip Logo are either registered Trademarks or Trademarks of Hitachi,Ltd. in Japan and in other countries.

Order Part No.

Order Part No.	Unit of Packaging	Packing Form	Unit of Order	Note
RKT102***MH	8,000 min	Reel	87,000	

Outline and Mark

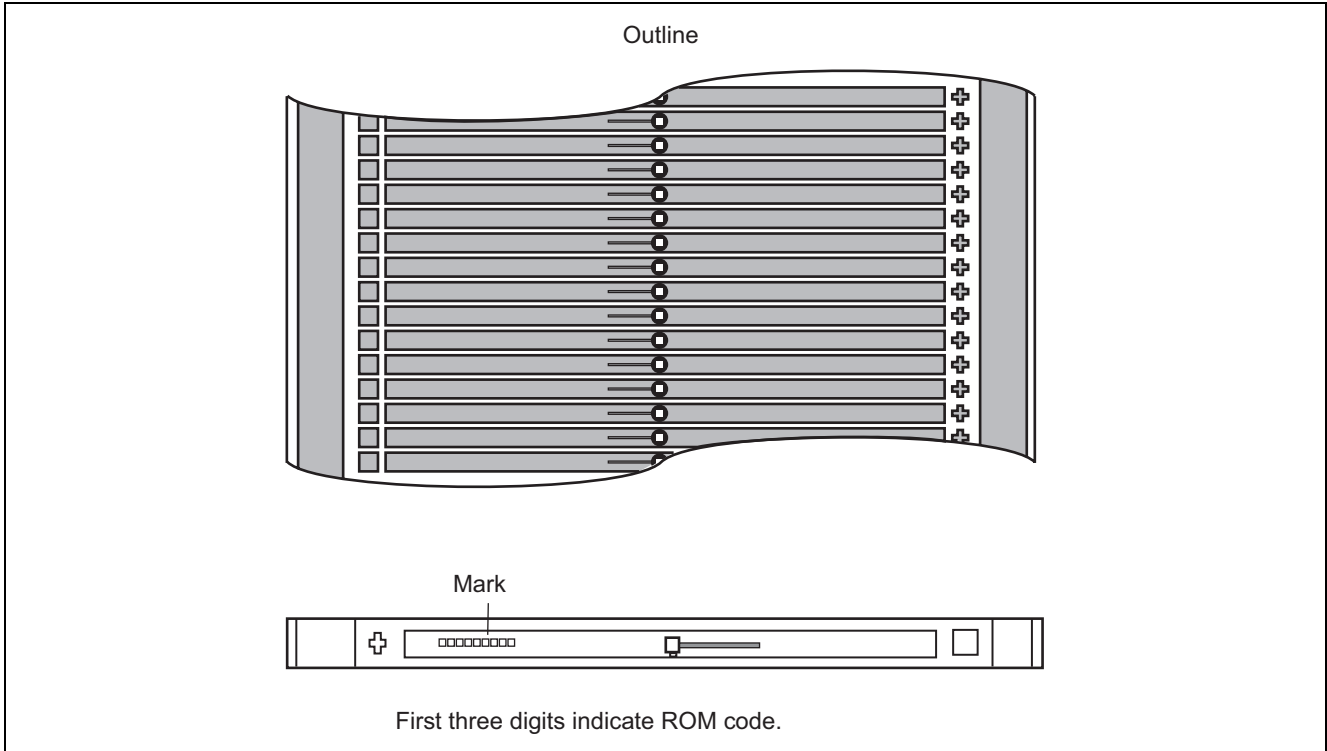

Absolute Maximum Ratings

Item	Symbol	Specification			Unit	Condition	Remark
		Min	Typ	Max			
Storage temperature	Tstg	-30	—	75	°C		
Ambient operation temperature	Ta	0	25	40	°C		No condensation
Received power	Pr	—	—	13.8	dBm		

Electrical Characteristics

Measurement conditions:

Unless otherwise specified, Ta = 25°C, fc = 2.402 to 2.421 GHz, reader power = 200 mW

Single-patch antenna, linearity polarized waves

Period of reading operations: 4 clock cycles, number of read bits: 128 bits

Item	Specification			Unit	Condition	Remark
	Min	Typ	Max			
Communication distance	6.5	—	23	cm	Note4	Note1
μ-Chip ID Check	—	Passed	—	—	EDC Check	Note2, Note3

Notes: 1. The distance at which the read μ-Chip ID value matches the indicated value and the EDC check is passed.

2. Verification value calculated from the read μ-Chip ID value.

3. Detail data of μ-Chip ID is describe on the commodity specification.

4. Relation between the inlet and antenna positions;

The planes of the metal-foil pattern for the antenna and the antenna itself should be parallel, the center of the inlet should be on the line that passes through the center of the antenna plane, and the inlet metal-foil pattern's longer side should be within the antenna's plane of polarization.

Reader Specifications and Type No.: HE-MU-380-SH14

Item	Symbol	Specification	Unit	Remarks
Operation temperature	Ta	25	°C	
Carrier frequency	fc	2.402 to 2.421	GHz	
Power	Pw	200	mW	
Data read cycle	Tfm	4	Clock	
Data read bit count	Nb	128	Bits	
Congestion control function	—	Action	—	

Cable Specifications

Item	Symbol	Specification	Unit	Remarks
Cable material	—	semi-rigid	—	
Total length of cable	L	20	cm	

Antenna Specifications and Type No.: PA1-2450ASA

Item	Symbol	Specification	Unit	Remarks
Operation temperature	Ta	25	°C	
Polarization	—	Linear	—	
Number of patches	—	1	pcs	
Gain	—	6	dBi	

Dimension of Inlet Outline

Tape Dimensions

The products, each of which consists of an antenna and chip, are aligned and mounted on tape as shown in the figure below.

The chip-mounting section is punched through if the chip is defective.

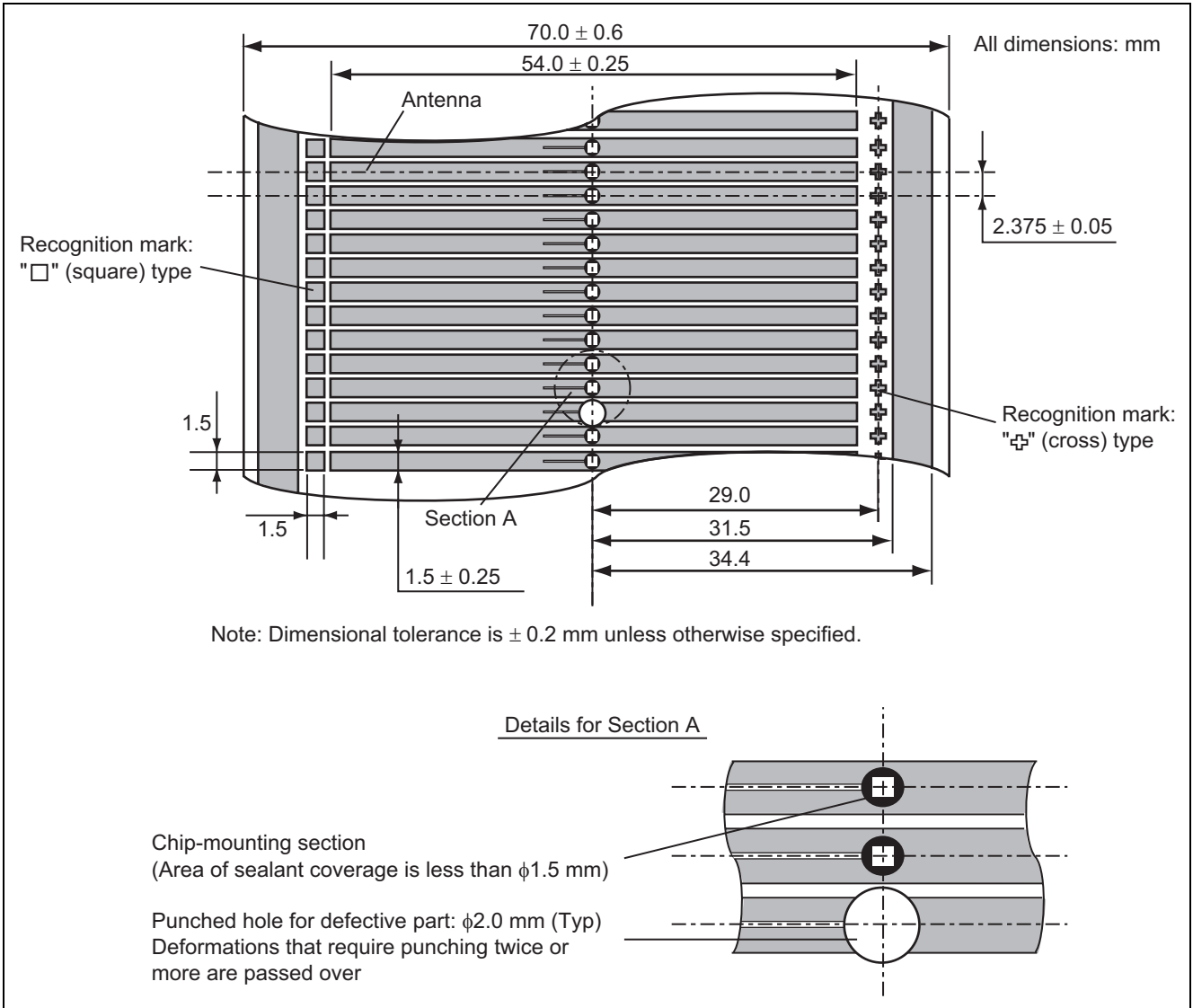

Leader and Trailer Sections

This product includes leader and trailer sections that precede and follow the product section, i.e. the section that carries the chips, as shown in the figure below.

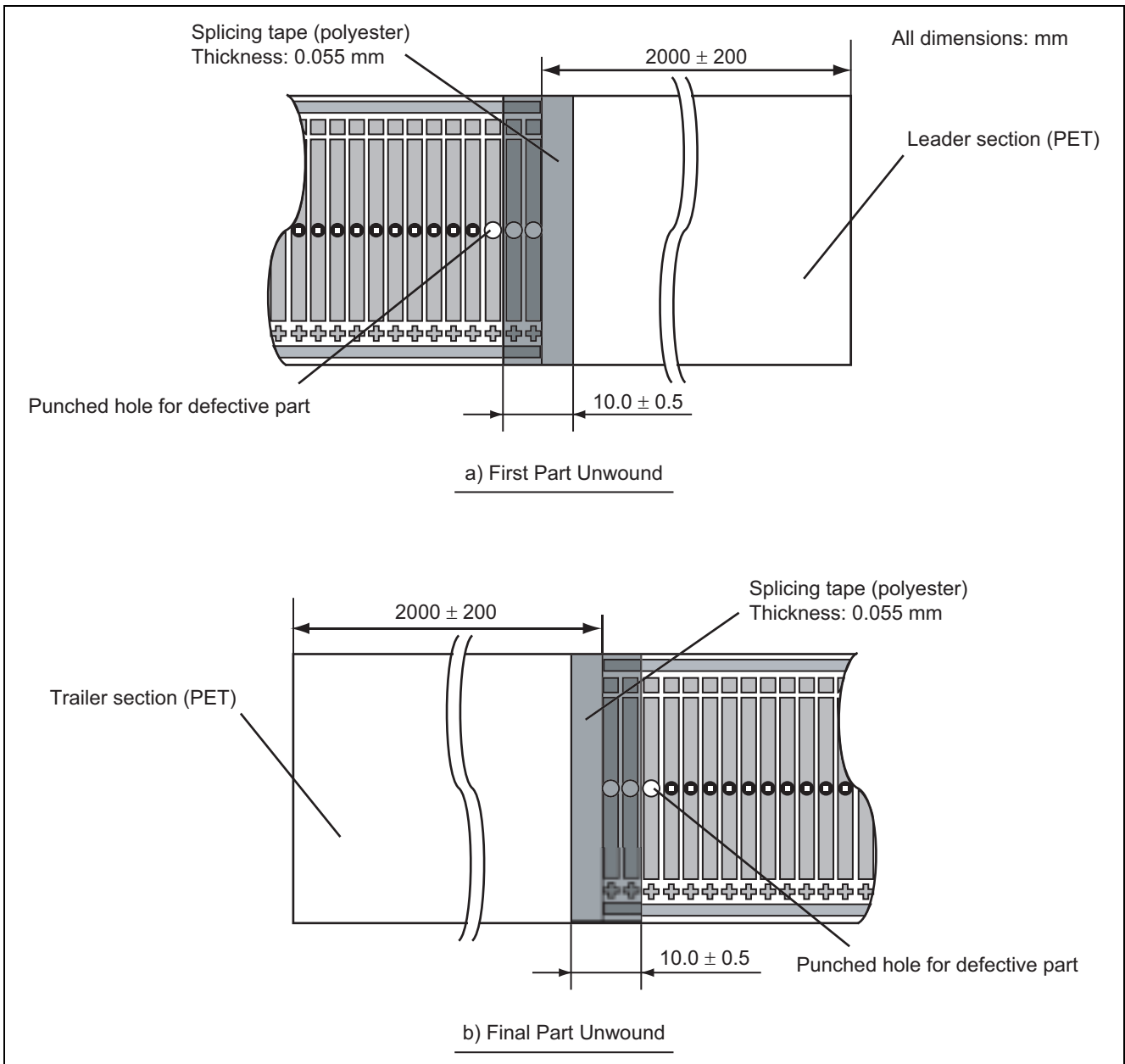

Punched Holes for Defective Part

Chips of defective parts will be punched through with the hole size of $\phi 2.0$ mm.

Jointed Segments of Tape

This product may include splices, where two tapes are pasted together, as shown below.

The number of splices is no more than 5 per reel (excluding the attachment of leader/trailer tapes ^{Note}).

Products covered by the splicing tape will be punched through as defective parts.

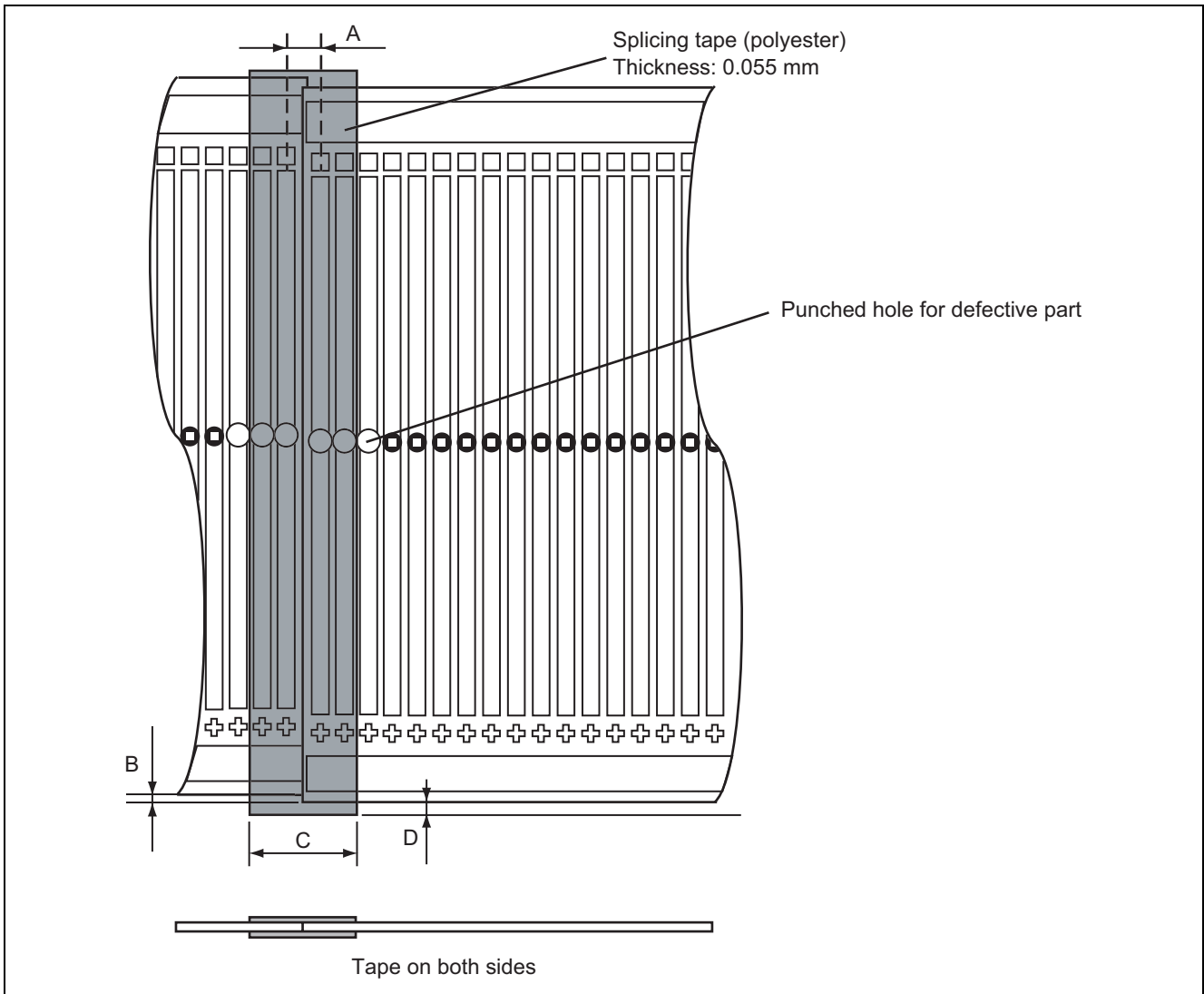

Dimension	Description	Specification
A	The antenna pitch at spliced part	2.375 ± 0.2 mm
B	Misalignment at spliced point	± 0.2 mm
C	Splicing tape width	10.0 ± 0.5 mm
D	Overflow of splicing tape	< 0.5 mm

Note: If leader/trailer parts are broken or spoiled by creases, the tape will be cut and jointed again.
 The attachment of leader/trailer will not be punched through as defective parts.

Packing Specifications

Packing Specifications and Quantity

- (1) As shipped, this product is packed in reel.
- (2) Quantity is 8,000 good pieces/reel Min. ^{Note}
- (3) Quantity of punched hole for defective part is 20% or less of total quantity of antenna.

Note: Tapes can be joined to increase the quantity.

Example of Labeling

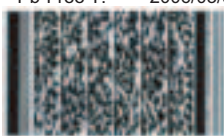

<p>(1) →</p> <p>(2) →</p> <p>(3) →</p> <p>(4) →</p> <p>(5) →</p> <p>(6) →</p>	<p>PID 06100P10CV-001</p> <p>D/N RKZ6.8TKJR1</p> <p>QTY 8000</p> <p>SPN RKZ6.8TKJR1 ZZZZ</p> <p>WP MADE IN JAPAN T/C 6C2 FL90030E0</p> <p>AS MADE IN JAPAN S.LOT FL90030E0</p>	<p>(9)</p> <p>Pb-Free T. 2006/03/06 ← (10)</p>  <p>(7)</p> <p>← (8)</p>
---	--	---

- (1) Pack-ID
- (2) Device Name
Note: Indicate "Q" the end of a device name only in the case of direct sale in Malaysia
- (3) Quantity
- (4) SAP Name
- (5) Country of Wafer Process
- (6) Country of Assembly
Japan → MADE IN JAPAN
Malaysia → MADE IN MALAYSIA
- (7) Trace code
- (8) Lot code
- (9) Pb-Free indication (Only for Pb-free product)
- (10) Date of Label issuance

Form of Delivery

(1) Paper tape for spacers

Paper tape is inserted as a spacer for the product tape.

When wound onto the reel, the product tape is oriented so that the antenna face is on the inner side.

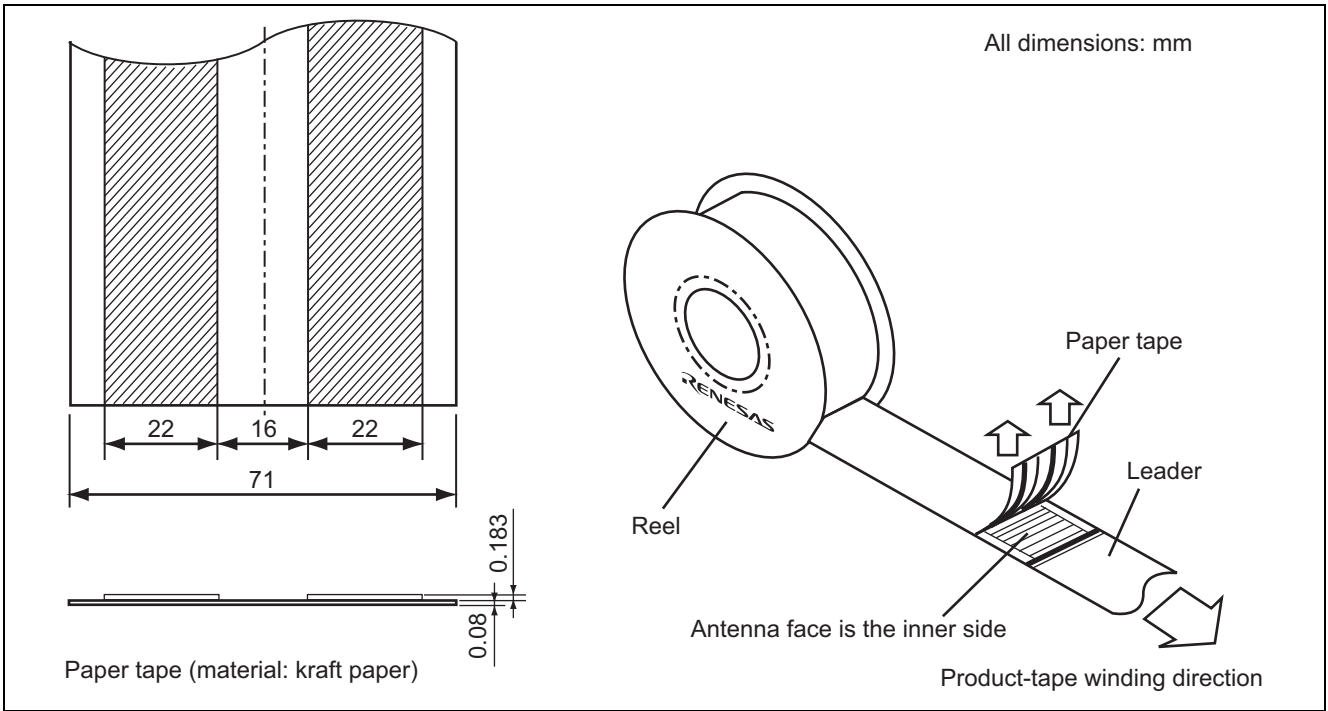

(2) Packing and reel dimensions

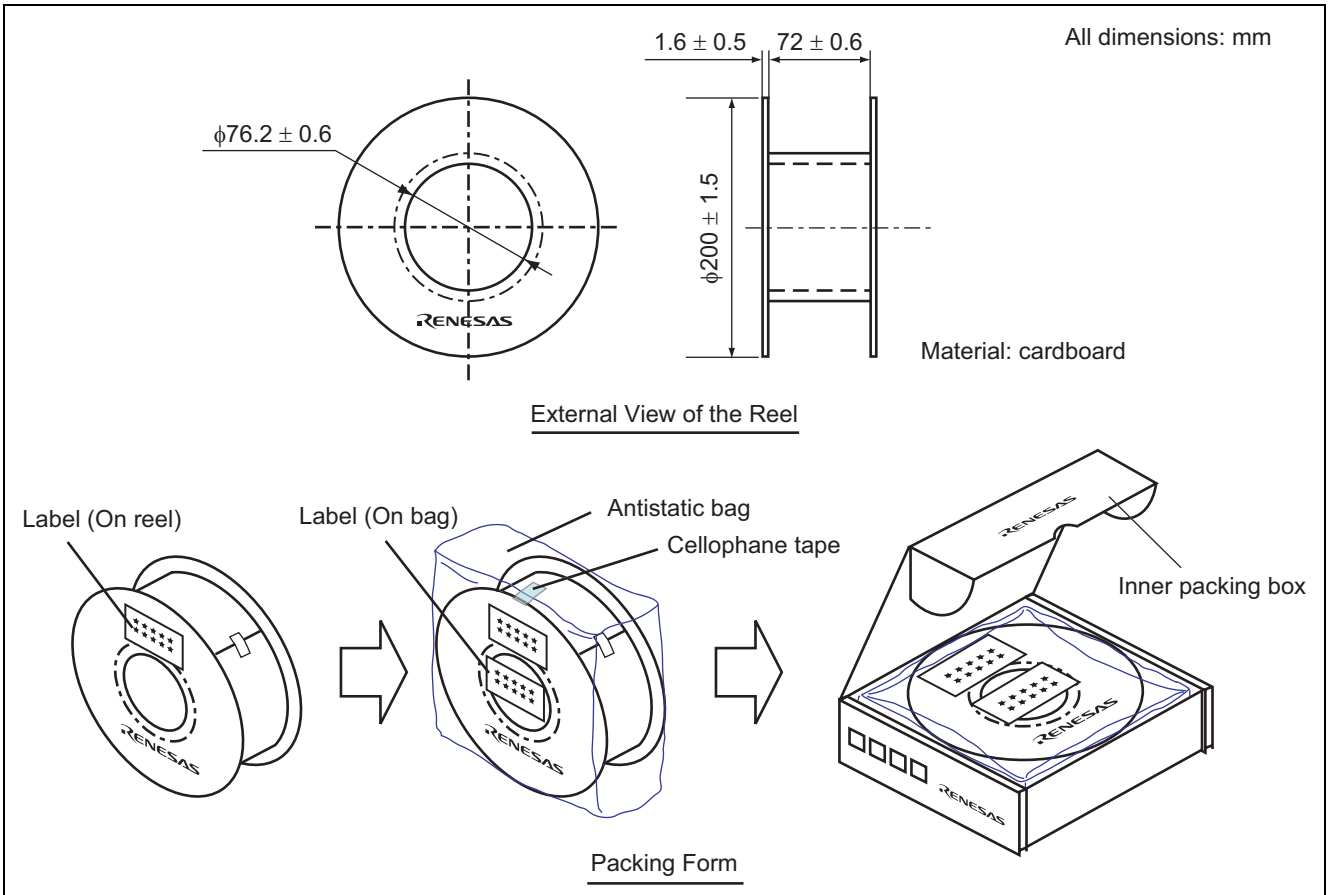

Appearance

There should not be any scratch or/and dirt that affect characteristics.

Quality Level

(Compliant with the JIS Z 9015)

Electrical characteristics: AQL = 4.0%

Appearance: AQL = 4.0%

Precautions on Usage

1. Renesas Technology does not guarantee the product characteristics after it has been through assembly on the customer side.
2. Please refer to the mounting manual. (Document No.: REJ11P0007-0100)
3. As for the structure of this product, resist on the surface of a metallic antenna is lost compared with past COA goods. It wishes the examination of reliability when using it.
4. There is a sign in the aluminum part for the edge on both sides of the antenna tape of this product. It is likely to be going to change without a previous notice in the future because this is the one for our shop floor control. There is no problem in the product performance at all even if for instance, there is a display "RKT101■■■■".

System Outline

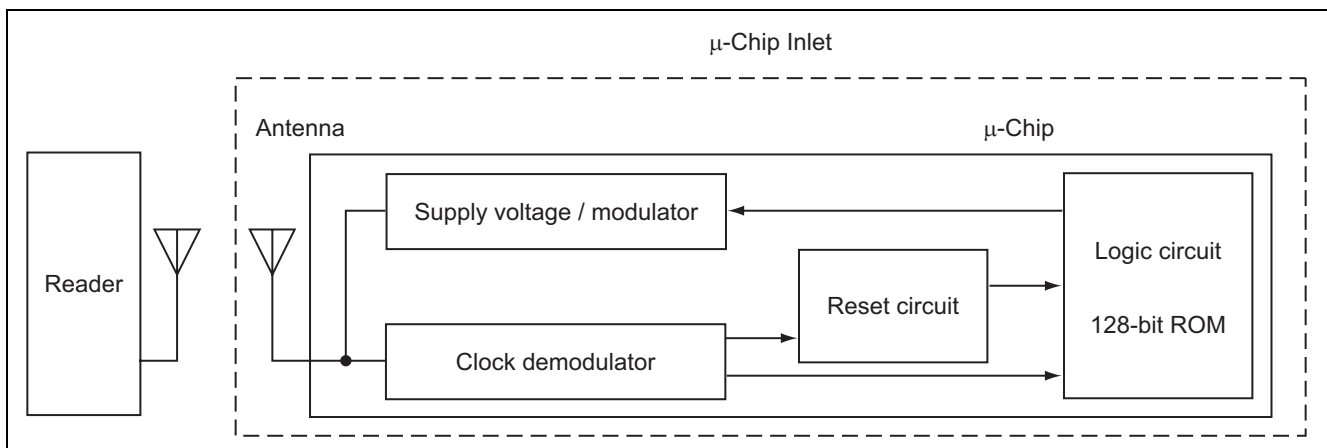

Function Blocks

Block Name	Description of Functions
Supply voltage/modulator	Generates power-supply voltage from carrier signals, varies the output impedance of the modulator circuit to match the input impedance of the antenna, and handles communications. The IC incorporates a power limiter for the protection of internal devices.
Reset circuit	Determines whether or not a clock signal is being supplied and cancels the reset mode in synchronization with the first clock cycle.
Clock demodulator	Demodulates the clock signal from the envelope signal of the received signal.
Logic circuit	The IC includes a congestion control circuit and an on-chip 128-bit ROM from which data signals are sent out in synchronization with the clock signal.

Notes:

1. This document is provided for reference purposes only so that Renesas customers may select the appropriate Renesas products for their use. Renesas neither makes warranties or representations with respect to the accuracy or completeness of the information contained in this document nor grants any license to any intellectual property rights or any other rights of Renesas or any third party with respect to the information in this document.
2. Renesas shall have no liability for damages or infringement of any intellectual property or other rights arising out of the use of any information in this document, including, but not limited to, product data, diagrams, charts, programs, algorithms, and application circuit examples.
3. You should not use the products or the technology described in this document for the purpose of military applications such as the development of weapons of mass destruction or for the purpose of any other military use. When exporting the products or technology described herein, you should follow the applicable export control laws and regulations, and procedures required by such laws and regulations.
4. All information included in this document such as product data, diagrams, charts, programs, algorithms, and application circuit examples, is current as of the date this document is issued. Such information, however, is subject to change without any prior notice. Before purchasing or using any Renesas products listed in this document, please confirm the latest product information with a Renesas sales office. Also, please pay regular and careful attention to additional and different information to be disclosed by Renesas such as that disclosed through our website. (<http://www.renesas.com>)
5. Renesas has used reasonable care in compiling the information included in this document, but Renesas assumes no liability whatsoever for any damages incurred as a result of errors or omissions in the information included in this document.
6. When using or otherwise relying on the information in this document, you should evaluate the information in light of the total system before deciding about the applicability of such information to the intended application. Renesas makes no representations, warranties or guaranties regarding the suitability of its products for any particular application and specifically disclaims any liability arising out of the application and use of the information in this document or Renesas products.
7. With the exception of products specified by Renesas as suitable for automobile applications, Renesas products are not designed, manufactured or tested for applications or otherwise in systems the failure or malfunction of which may cause a direct threat to human life or create a risk of human injury or which require especially high quality and reliability such as safety systems, or equipment or systems for transportation and traffic, healthcare, combustion control, aerospace and aeronautics, nuclear power, or undersea communication transmission. If you are considering the use of our products for such purposes, please contact a Renesas sales office beforehand. Renesas shall have no liability for damages arising out of the uses set forth above.
8. Notwithstanding the preceding paragraph, you should not use Renesas products for the purposes listed below:
 - (1) artificial life support devices or systems
 - (2) surgical implantations
 - (3) healthcare intervention (e.g., excision, administration of medication, etc.)
 - (4) any other purposes that pose a direct threat to human lifeRenesas shall have no liability for damages arising out of the uses set forth in the above and purchasers who elect to use Renesas products in any of the foregoing applications shall indemnify and hold harmless Renesas Technology Corp., its affiliated companies and their officers, directors, and employees against any and all damages arising out of such applications.
9. You should use the products described herein within the range specified by Renesas, especially with respect to the maximum rating, operating supply voltage range, movement power voltage range, heat radiation characteristics, installation and other product characteristics. Renesas shall have no liability for malfunctions or damages arising out of the use of Renesas products beyond such specified ranges.
10. Although Renesas endeavors to improve the quality and reliability of its products, IC products have specific characteristics such as the occurrence of failure at a certain rate and malfunctions under certain use conditions. Please be sure to implement safety measures to guard against the possibility of physical injury, and injury or damage caused by fire in the event of the failure of a Renesas product, such as safety design for hardware and software including but not limited to redundancy, fire control and malfunction prevention, appropriate treatment for aging degradation or any other applicable measures. Among others, since the evaluation of microcomputer software alone is very difficult, please evaluate the safety of the final products or system manufactured by you.
11. In case Renesas products listed in this document are detached from the products to which the Renesas products are attached or affixed, the risk of accident such as swallowing by infants and small children is very high. You should implement safety measures so that Renesas products may not be easily detached from your products. Renesas shall have no liability for damages arising out of such detachment.
12. This document may not be reproduced or duplicated, in any form, in whole or in part, without prior written approval from Renesas.
13. Please contact a Renesas sales office if you have any questions regarding the information contained in this document, Renesas semiconductor products, or if you have any other inquiries.



RENESAS SALES OFFICES

<http://www.renesas.com>

Refer to "<http://www.renesas.com/en/network>" for the latest and detailed information.

Renesas Technology America, Inc.

450 Holger Way, San Jose, CA 95134-1368, U.S.A
Tel: <1> (408) 382-7500, Fax: <1> (408) 382-7501

Renesas Technology Europe Limited

Dukes Meadow, Millboard Road, Bourne End, Buckinghamshire, SL8 5FH, U.K.
Tel: <44> (1628) 585-100, Fax: <44> (1628) 585-900

Renesas Technology (Shanghai) Co., Ltd.

Unit 204, 205, AZIACenter, No.1233 Lujiazui Ring Rd, Pudong District, Shanghai, China 200120
Tel: <86> (21) 5877-1818, Fax: <86> (21) 6887-7898

Renesas Technology Hong Kong Ltd.

7th Floor, North Tower, World Finance Centre, Harbour City, 1 Canton Road, Tsimshatsui, Kowloon, Hong Kong
Tel: <852> 2265-6688, Fax: <852> 2730-6071

Renesas Technology Taiwan Co., Ltd.

10th Floor, No.99, Fushing North Road, Taipei, Taiwan
Tel: <886> (2) 2715-2888, Fax: <886> (2) 2713-2999

Renesas Technology Singapore Pte. Ltd.

1 Harbour Front Avenue, #06-10, Keppel Bay Tower, Singapore 098632
Tel: <65> 6213-0200, Fax: <65> 6278-8001

Renesas Technology Korea Co., Ltd.

Kukje Center Bldg. 18th Fl., 191, 2-ka, Hangang-ro, Yongsan-ku, Seoul 140-702, Korea
Tel: <82> (2) 796-3115, Fax: <82> (2) 796-2145

Renesas Technology Malaysia Sdn. Bhd

Unit 906, Block B, Menara Amcorp, Amcorp Trade Centre, No.18, Jalan Persiaran Barat, 46050 Petaling Jaya, Selangor Darul Ehsan, Malaysia
Tel: <603> 7955-9390, Fax: <603> 7955-9510