

OTHER

∅ 1.8m/m p.c Board
Pin Terminal

YPT-018S/YPT-018M/YPT-012

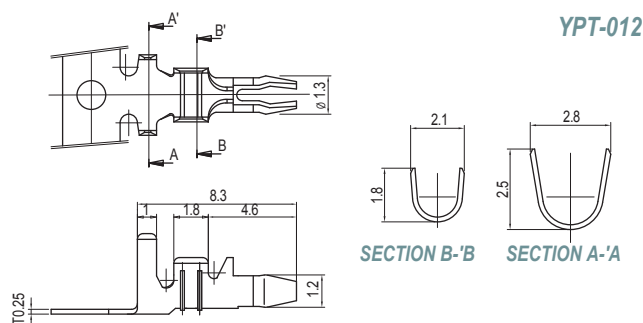
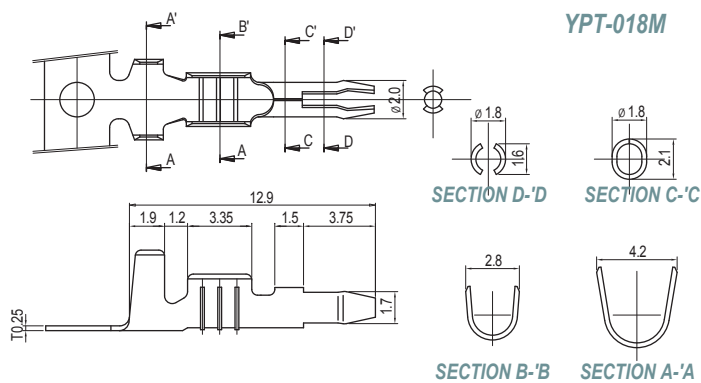
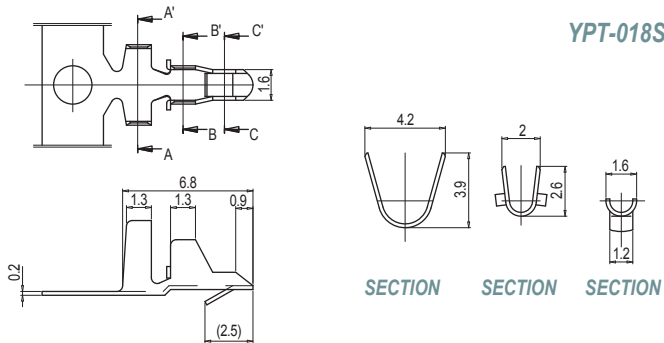
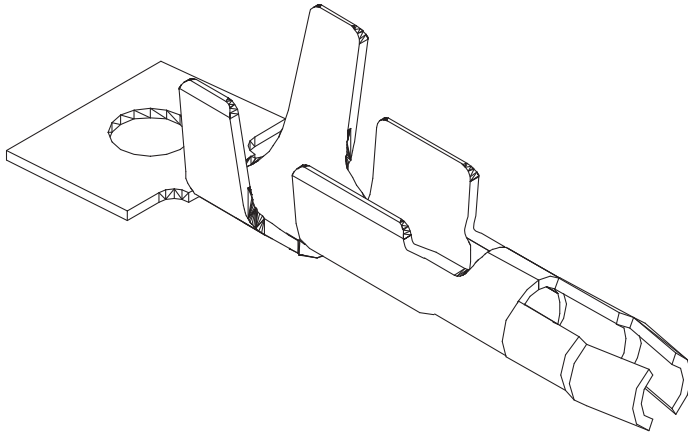

Material

I/NO	DESCRIPTION	TITLE	AWG	MATERIAL	FINISH
1	TERMINAL	YPT018S	#22~#22	Brass	Tin-Plated
2	TERMINAL	YPT018M	#22~#24	Brass	Tin-Plated
3	TERMINAL	YPT012	#26~#30	Brass	Tin-Plated

Specification

ITEM	SPEC
Voltage Rating	AC/DC 250V
Current Rating	AC/DC 3A
Operating Temperature	-25℃~+85℃
Contact Resistance	30mΩ MAX
Withstanding Voltage	-
Insulation Resistance	-
Applicable Wire	AWG #22~#30
Applicable P.C.B	∅ 1.8
Applicable FPC/FFC	-
Solder Height	-
Crimp Tensile Strength	AWG #20 : 4.0kgfMIN AWG #22 : 3.5kgfMIN AWG #24 : 2.0kgfMIN AWG #26 : 1.5kgfMIN AWG #28 : 1.0kgfMIN AWG #30 : 0.8kgfMIN
UL FILE NO	E157752