

# 980nm Pump Laser Module - Grating Stabilized, 400mW LC95

These lasers are designed as pump sources for Erbium-Doped Fiber Amplifier (EDFA) applications. Processes and techniques of coupling the fiber to the laser allow high output powers that are very stable with both time and temperature. The grating is located in the pigtail to stabilize the wavelength.

Devices are available with kink free output powers to 400mW.

The LC95 series pump module utilises a double Fiber Bragg Grating design for enhanced wavelength and power stability performance. This product has been designed to ensure superior wavelength locking over drive current, temperature and optical feedback changes.

### Features:

- Double Fiber Bragg Grating wavelength stabilization
- High output power, up to 400mW kink free
- Single-mode fiber pigtail
- Internal thermoelectric heatpump and monitor photodiode
- Hermetically sealed 14-pin butterfly package
- Telcordia GR-468-CORE compliant
- Field proven high reliability
- RoHS compliant 

### Applications:

- Low noise EDFAs
- Dense wavelength division multiplexing (DWDM) EDFAs
- CATV Applications

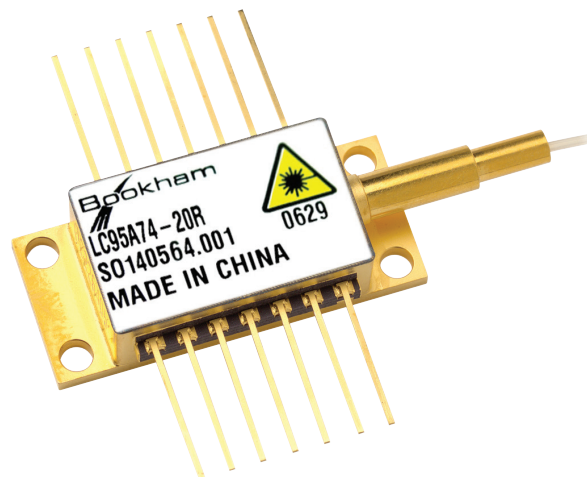

## Characteristics

Conditions unless otherwise stated: Case temperature -20 to +75°C  
 Submount temperature 25°C  
 Monitor diode bias -5V  
 CW operation

Kink-free fiber-coupled output power: (wavelength = 974nm)	LC95A74-20R	300mW	LC95G74-20R	360mW
	LC95B74-20R	310mW	LC95H74-20R	370mW
	LC95C74-20R	320mW	LC95J74-20R	380mW
	LC95D74-20R	330mW	LC95K74-20R	390mW
	LC95E74-20R	340mW	LC95L74-20R	400mW
	LC95F74-20R	350mW		

Parameter	Min	Typ	Max	Unit
Threshold current ( $I_{th}$ )		35	45	mA
Operating drive current ( $I_f$ )		A thru F G thru L	650 700	mA
Forward voltage		1.9	2.5	V
Centre wavelength ( $\lambda_c$ )		974		nm
Spectral width (RMS @ -13dB)		0.2	1	nm
Spectrum stability (t = 60s)			±0.2	nm
Temperature dependence of peak wavelength			0.02	nm/°C
Wavelength tolerance			±0.5	nm
Monitor detector responsivity	1.0	8	25	µA/mW
Monitor dark current			50	nA
Thermistor resistance (at 25°C)	9.5	10	10.5	kΩ
Intended laser submount operating temperature	20	25	30	°C
Power Stability Peak-to-peak, t = 60s, DC to 50kHz sampling, $T_c = 25^\circ\text{C}$				
>20mW			0.2	dB
10 – 20mW			0.5	dB
3.5 – 10mW			1	dB
Heatpump current ( $\Delta T = 50^\circ\text{C}$ , $I_f = 700\text{mA}$ )			1.5	A
Heatpump voltage ( $\Delta T = 50^\circ\text{C}$ , $I_f = 700\text{mA}$ )			2.8	V

Product with a tight fibre power Tracking Error specification is available on request.

### Absolute Maximum Ratings

Parameter	Min	Max	Unit
Operating temperature	-20	75	°C
Storage temperature	-40	85	°C
Laser forward current		1000	mA
Laser reverse voltage		2	V
Heatpump current		1.8	A
Lead soldering temperature (10s max)		260	°C
Fibre bend radius	30		mm

### Package Outline Drawing and Dimensions

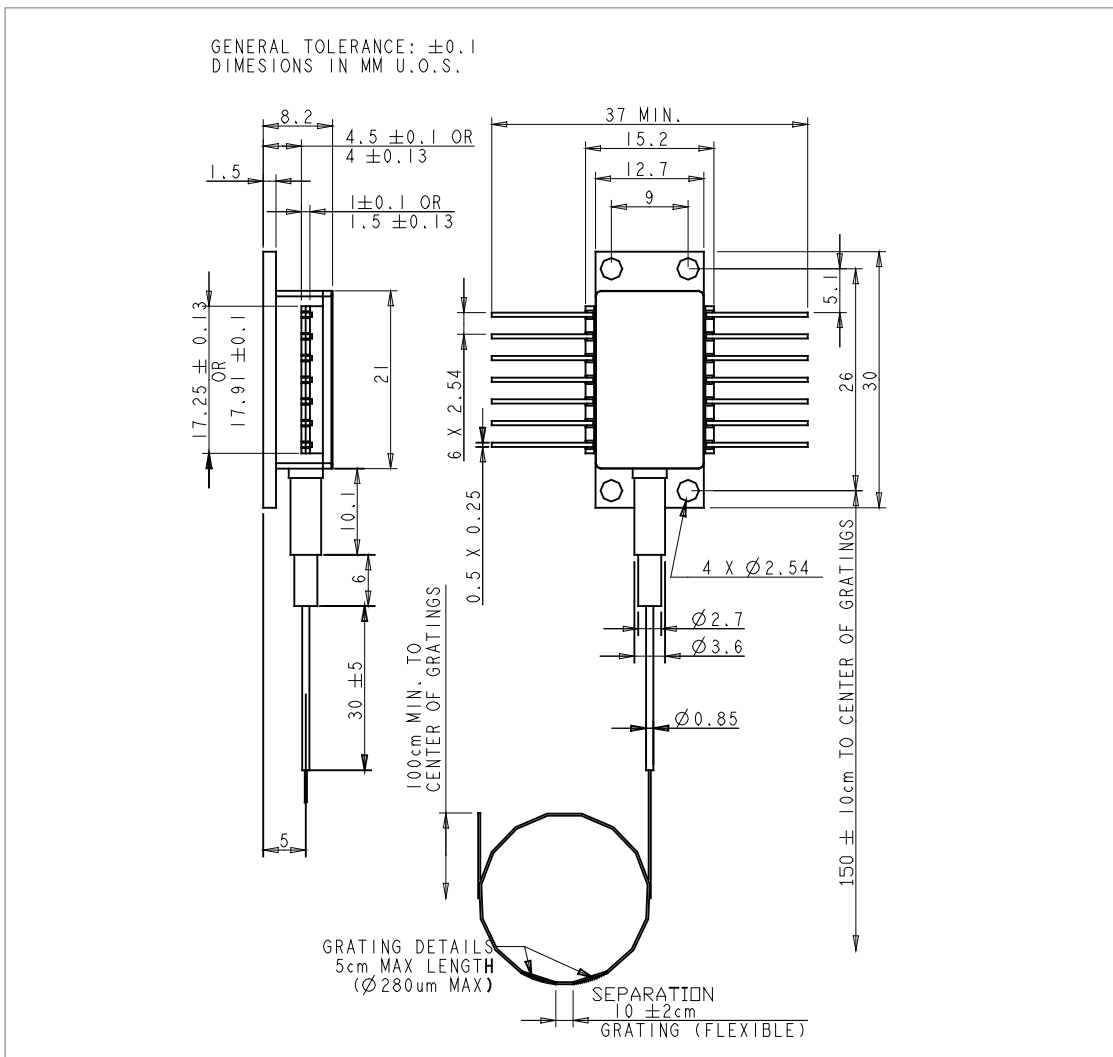

3

#### Fiber Specification

Puremode HI980 or equivalent 250 $\mu$ m primary coated.

## Connections

Pin #	Description	Pin #	Description
1	Peltier cooler (+)	8	Not connected
2	Thermistor	9	Not connected
3	Monitor anode (-)	10	Laser anode (+)
4	Monitor cathode (+)	11	Laser cathode (-)
5	Thermistor	12	Not connected
6	Not connected	13	Case ground
7	Not connected	14	Peltier cooler (-)

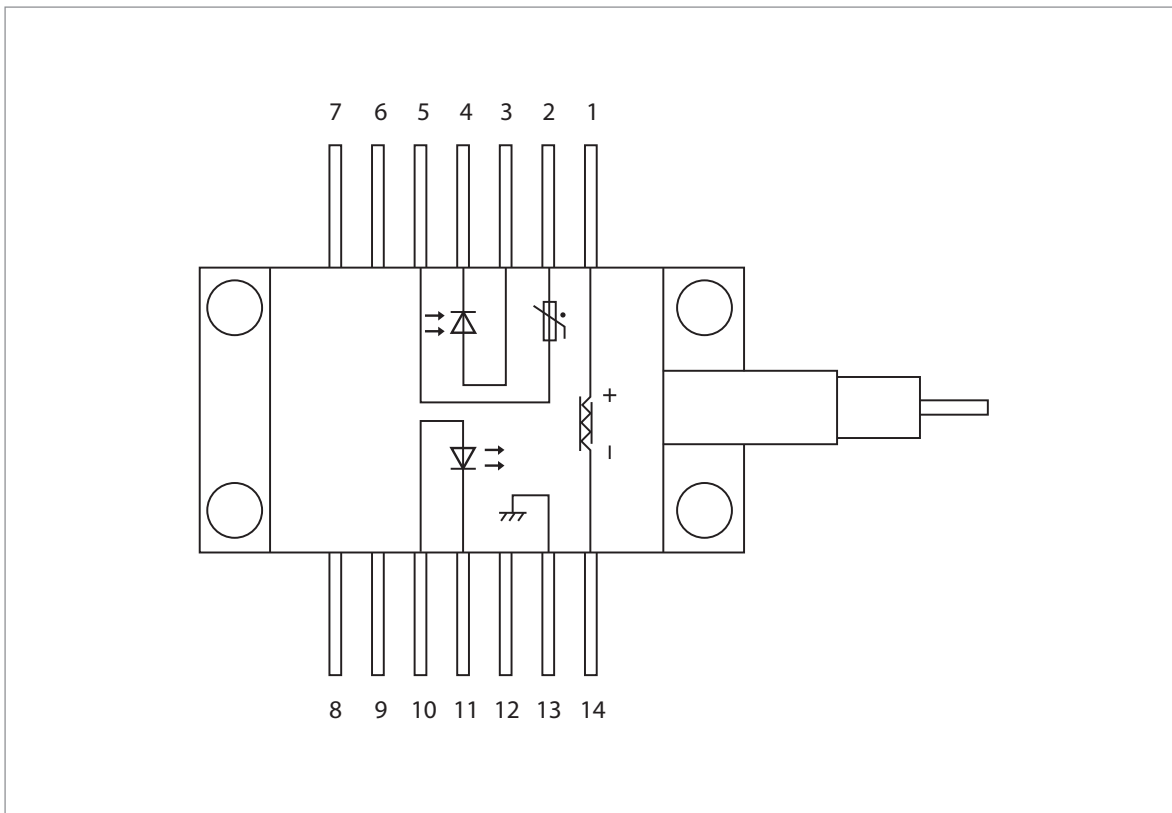

## RoHS Compliance



Bookham is fully committed to environment protection and sustainable development and has set in place a comprehensive program for removing polluting and hazardous substances from all of its products. The relevant evidence of RoHS compliance is held as part of our controlled documentation for each of our compliant products. RoHS compliance parts are available to order, please refer to the ordering information section for further details.

### Ordering Information:

LC95A74-20R	300mW	LC95G74-20R	360mW
LC95B74-20R	310mW	LC95H74-20R	370mW
LC95C74-20R	320mW	LC95J74-20R	380mW
LC95D74-20R	330mW	LC95K74-20R	390mW
LC95E74-20R	340mW	LC95L74-20R	400mW
LC95F74-20A	350mW		

## Contact Information

### North America Bookham Worldwide Headquarters

2584 Junction Ave.  
San Jose  
CA 95134  
USA

- Tel: +1 408 919 1500
- Fax: +1 408 919 6083

[www.bookham.com](http://www.bookham.com)  
[sales@bookham.com](mailto:sales@bookham.com)

### Europe Paignton Office

Brixham Road  
Paignton  
Devon  
TQ4 7BE  
United Kingdom

- Tel: +44 (0) 1803 66 2000
- Fax: +44 (0) 1803 66 2801

### Asia Shenzhen Office

2 Phoenix Road  
Futian Free Trade Zone  
Shenzhen 518038  
China

- Tel: +86 755 33305888
- Fax: +86 755 33305805  
+86 755 33305807

### Important Notice

Performance figures, data and any illustrative material provided in this data sheet are typical and must be specifically confirmed in writing by Bookham before they become applicable to any particular order or contract. In accordance with the Bookham policy of continuous improvement specifications may change without notice. The publication of information in this data sheet does not imply freedom from patent or other protective rights of Bookham or others. Further details are available from any Bookham sales representative.

