

High Performance, Low Noise Boost Converter

General Description

The RT9270 is a high performance, low noise, fixed frequency step up DC-DC Converter. The RT9270 converts input voltage ranging 2.3V to 5.5V into output voltage up to 14V. Current mode control with external compensation network makes it easy to stabilize the system and keep maximum flexibility. Programmable soft start function minimizes impact on the input power system. Internal power MOSFET with very low $R_{DS(ON)}$ provides high efficiency. The RT9270 automatically transits from PWM to PSM (Pulse Skipping Mode) during light load condition further increasing efficiency. 670kHz and 1.3MHz operation frequency options provide flexibility of minimum output filter size, maximum efficiency and low BOM cost.

The RT9270 also provides comprehensive protection functions such as UVLO, OCP, OTP, OVP and short circuit protection.

Ordering Information

- RT9270 □ □
- Package Type
F : MSOP-8
 - Operating Temperature Range
P : Pb Free with Commercial Standard
G : Green (Halogen Free with Commercial Standard)

Note :

RichTek Pb-free and Green products are :

- ▶RoHS compliant and compatible with the current requirements of IPC/JEDEC J-STD-020.
- ▶Suitable for use in SnPb or Pb-free soldering processes.
- ▶100%matte tin (Sn) plating.

Features

- **90% Efficiency**
- **V_{IN} Operating Range: 2.3V to 5.5V**
- **1.9A, 0.25 Ω , 16V Internal Power MOSFET**
- **670kHz and 1.3MHz Operation Frequency**
- **External Compensation Network**
- **Programmable Soft Start Function**
- **Small MSOP8 Package**
- **Short Circuit Protection , Thermal Shutdown, OVP are included**
- **RoHS Compliant and 100% Lead (Pb)-Free**

Applications

- TFT LCD panel
- OLED Display
- PCMCIA Cards
- Portable Device

Pin Configurations

(TOP VIEW)

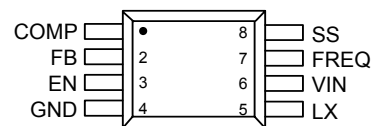

MSOP-8

Typical Application Circuit

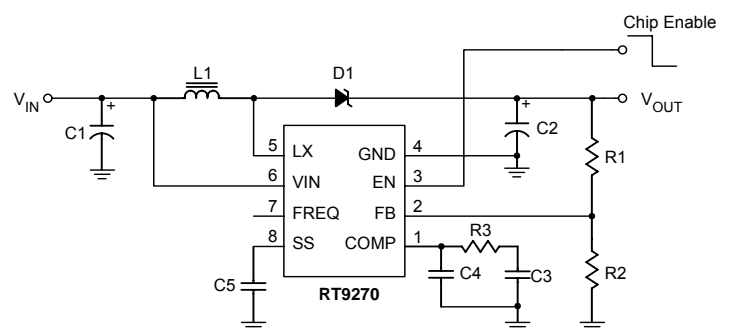

Figure 1

Pin Description

COMP (Pin 1)

Compensation Pin for Error Amplifier. Connect a compensation network to ground. See the Component Selection Table for the loop compensation.

FB (Pin 2)

Feedback Pin. Connect an external resistor-divider tap to FB. The reference voltage is 1.24V and set V_{OUT} according to: $V_{OUT} = 1.24V (1 + R1 / R2)$. See Figure 1.

EN (Pin 3)

Shutdown Control Input. Connect EN to GND to turn off the RT9270.

GND (Pin 4)

Ground.

LX (Pin 5)

Switch Pin. Connect the inductor and catch diode to LX pin. Widen and shorten the connected trace to minimize EMI.

VIN (Pin 6)

Supply Pin. Place at least a 1uF ceramic capacitor close to RT9270 for bypassing noise.

FREQ (Pin 7)

Frequency Select Pin. Oscillator frequency is 670kHz as FREQ connected to GND, and 1.3MHz as FREQ connected to VIN. A 5uA pull-down current is sinking on this pin.

SS (Pin 8)

Soft-Start Control Pin. Connect a soft-start capacitor (C_{SS}) to this pin. A 4uA constant current charges the soft-start capacitor. When EN connected to GND, the soft-start capacitor is discharged. When EN connected to VIN high, the soft-start capacitor is charged to VIN. Leave floating for not using soft-start.

Absolute Maximum Ratings (Note 1)

- Supply Voltage, V_{IN} ----- -0.3 to 6V
- LX to GND ----- -0.3V to 16V
- The other pins ----- -0.3V to 6V
- Power Dissipation, $P_D @ T_A = 70^\circ C$
 MSOP-8 ----- 300mW
- Junction Temperature ----- 150°C
- Lead Temperature (Soldering, 10 sec.) ----- 260°C
- Operation Temperature Range ----- -40°C to 85°C
- Storage Temperature Range ----- -65°C to 150°C
- ESD Susceptibility (Note 2)
 HBM (Human Body Mode) ----- 2kV
 MM (Machine Mode) ----- 200V

Recommended Operating Conditions (Note 3)

- Ambient Temperature Range ----- 0°C to 70°C
- Junction Temperature Range ----- 0°C to 125°C

Electrical Characteristics

($V_{IN} = 3V$, FREQ left floating, $T_A = 25^\circ C$, Unless Otherwise specification)

Parameter	Symbol	Test Condition	Min	Typ	Max	Units
System Supply Input						
Operation voltage Range	V_{IN}	FREQ = GND	2.3	--	5.5	V
		FREQ = V_{IN}	2.5	--	5.5	
Under Voltage Lock Out	UVLO		2	2.2	2.3	V
Power On Reset Hysteresis			--	200	--	mV
Quiescent Current	I_{IN}	$V_{FB}=1.3V$, No switching	--	270	600	uA
	I_{IN}	$V_{FB}=1.0V$, Switching, No load	--	1.76	5	mA
Shut Down Current	I_{IN}	EN = GND	--	--	1	uA
Soft start Current	I_{SS}		--	4	9	uA
Switching Regulator Oscillator						
Free Run Frequency	f_{OSC}	FREQ=GND	520	670	850	kHz
		FREQ= V_{IN}	960	1300	1500	
Maximum Duty Cycle (Note 4)		FREQ = GND	82	90	96	%
		FREQ = V_{IN}	74	77	80	
Reference Voltage						
Feedback Voltage	V_{FB}		1.216	1.24	1.264	V
Error Amplifier						
GM		(Note 4)	--	1.1	--	ms
Feedback Voltage Line Regulation		$2.3V < V_{IN} < 5.5V$	--	0.12	0.3	%/V

To be continued

Parameter	Symbol	Test Condition	Min	Typ	Max	Units
MOSFET						
On Resistance of MOSFET	R _{DS(ON)}		--	250	550	mΩ
Current Limitation			--	1.9	--	A

Note 1. Stresses listed as the above "Absolute Maximum Ratings" may cause permanent damage to the device. These are for stress ratings. Functional operation of the device at these or any other conditions beyond those indicated in the operational sections of the specifications is not implied. Exposure to absolute maximum rating conditions for extended periods may remain possibility to affect device reliability.

Note 2. Devices are ESD sensitive. Handling precaution recommended.

Note 3. The device is not guaranteed to function outside its operating conditions.

Note 4. Guaranteed by Design.

Typical Operating Characteristics

Efficiency vs. Output Current

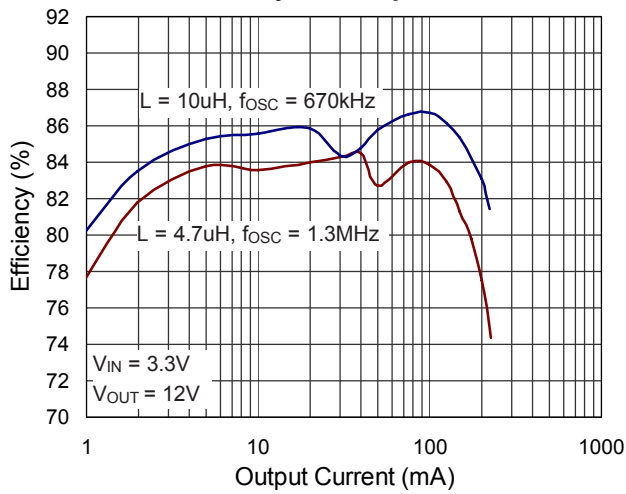

Efficiency vs. Output Current

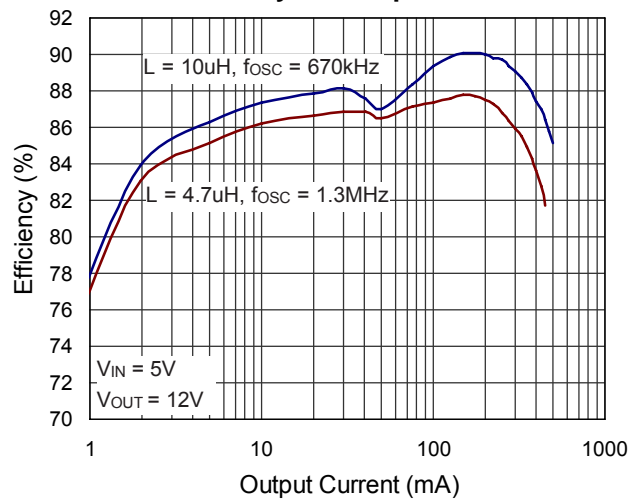

Frequency vs. VIN

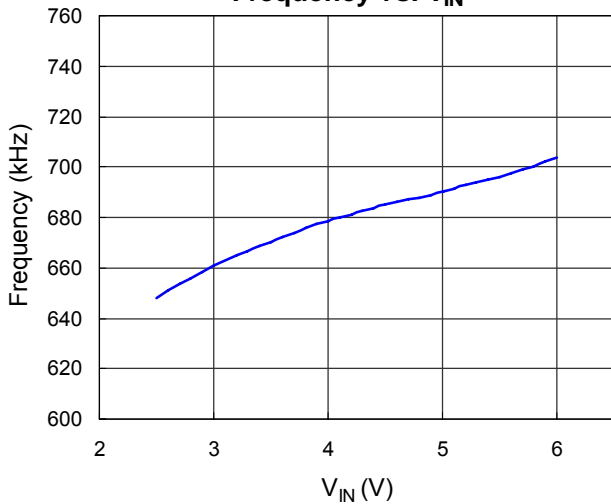

Frequency vs. VIN

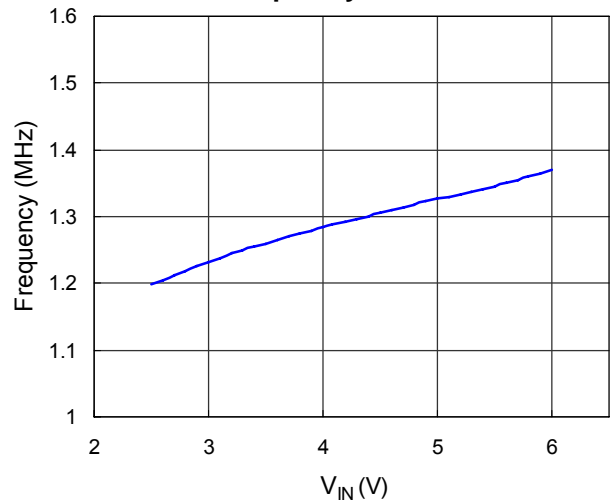

Frequency vs. Temperature

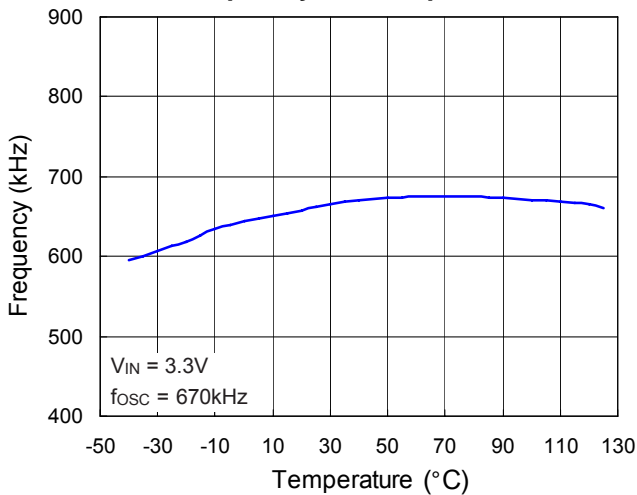

Frequency vs. Temperature

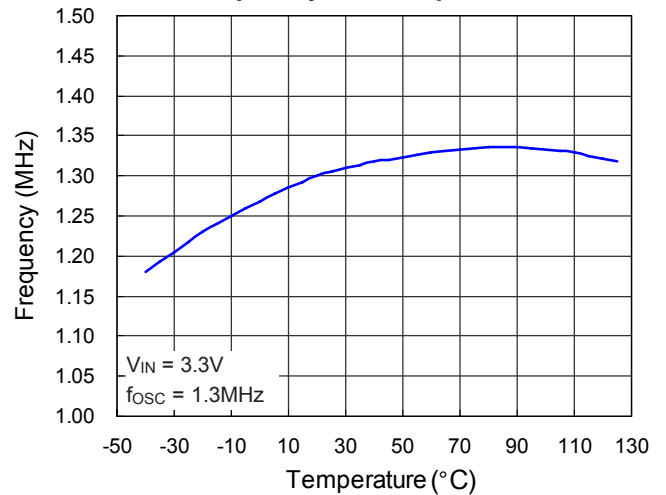

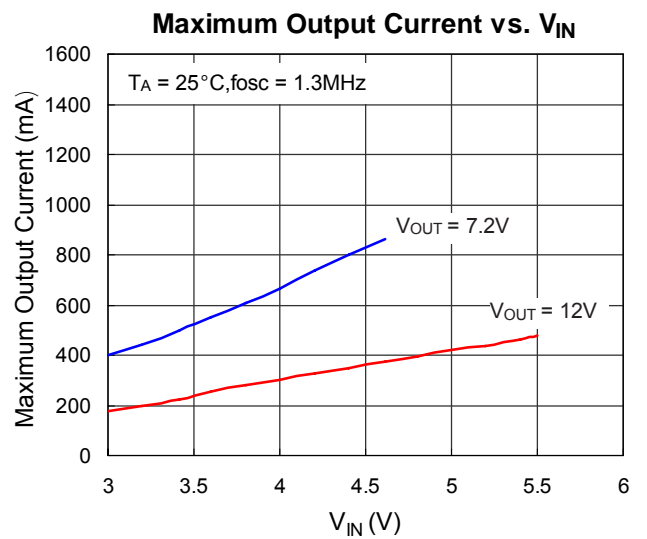
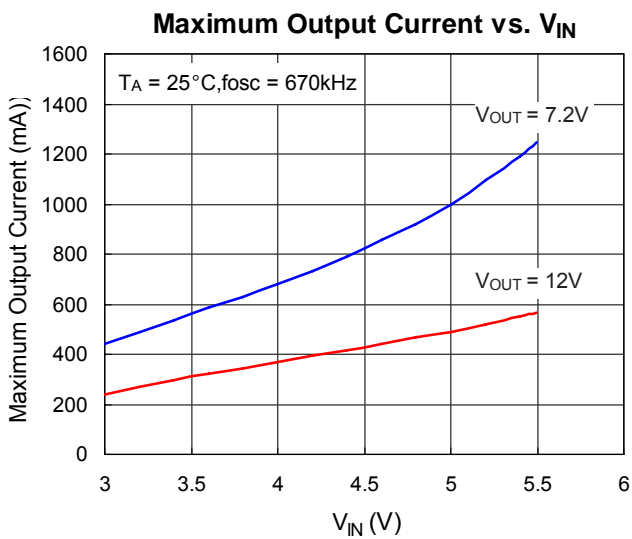
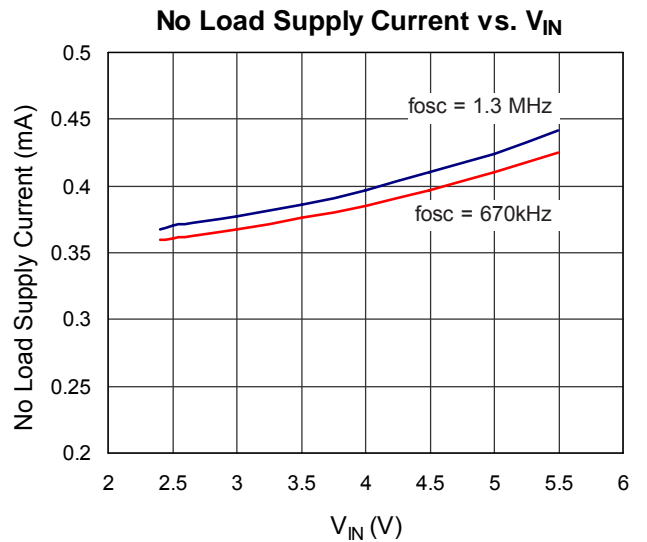
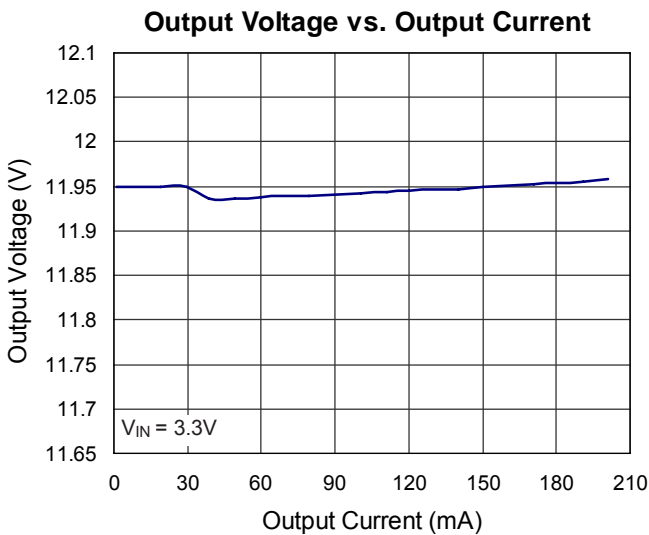
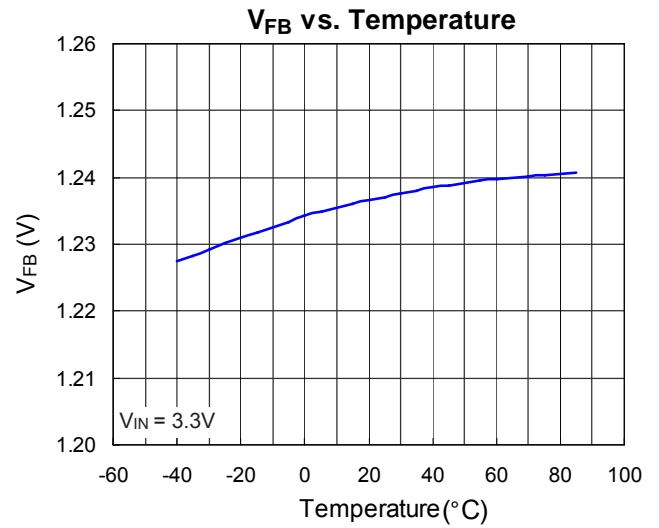
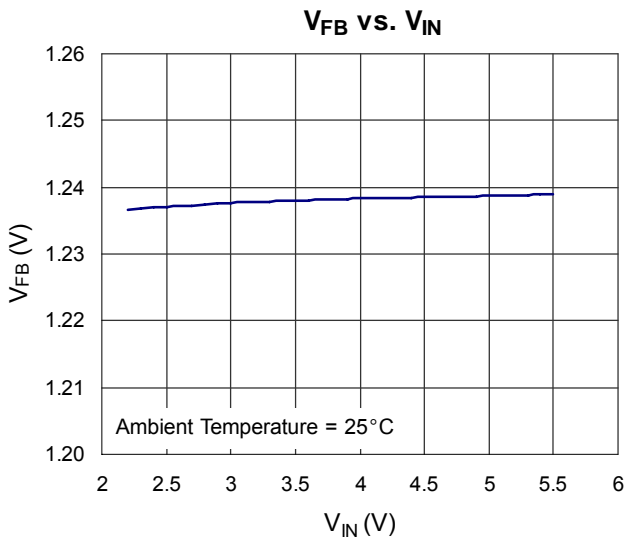

Load-Transient Response

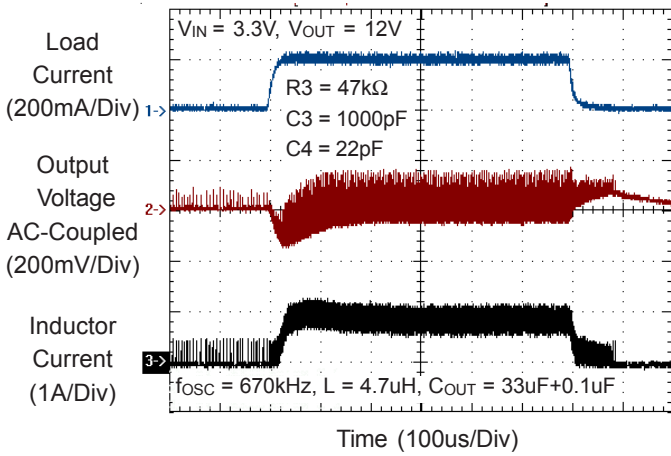

Load-Transient Response

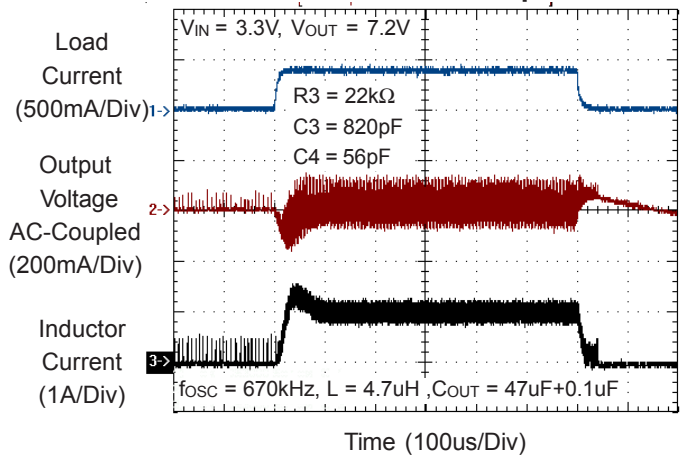

Startup Waveform Without Soft-Start

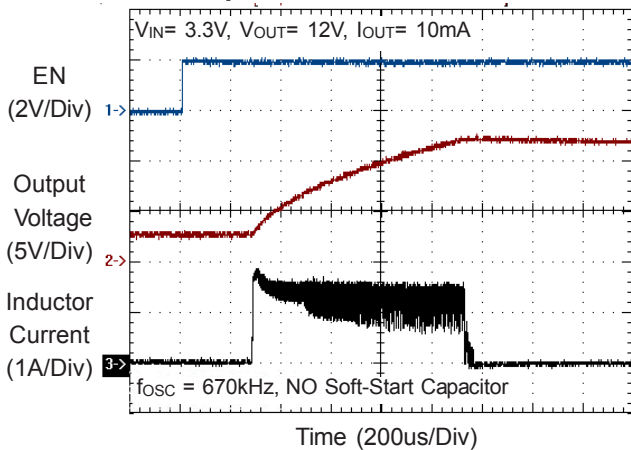

Startup Waveform With Soft-Start

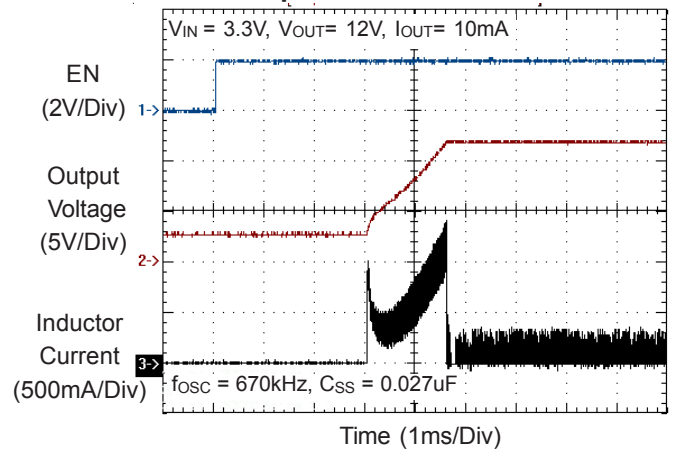

Startup Waveform With Soft-Start

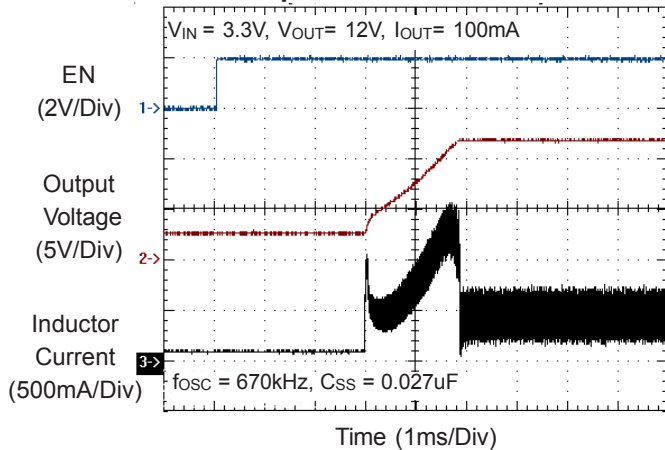

Switching Waveform

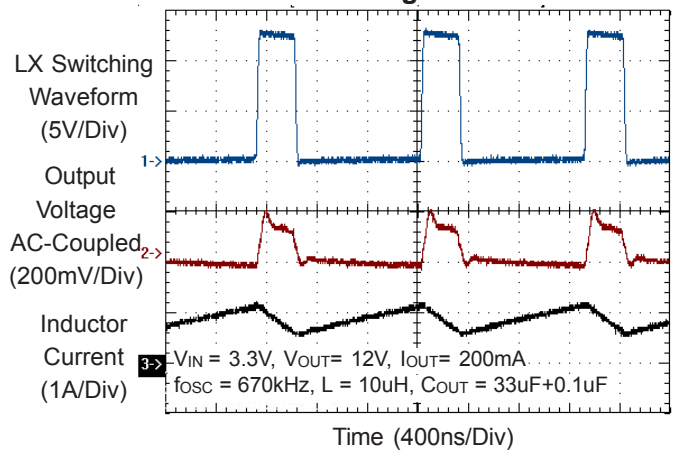

OCP Waveform

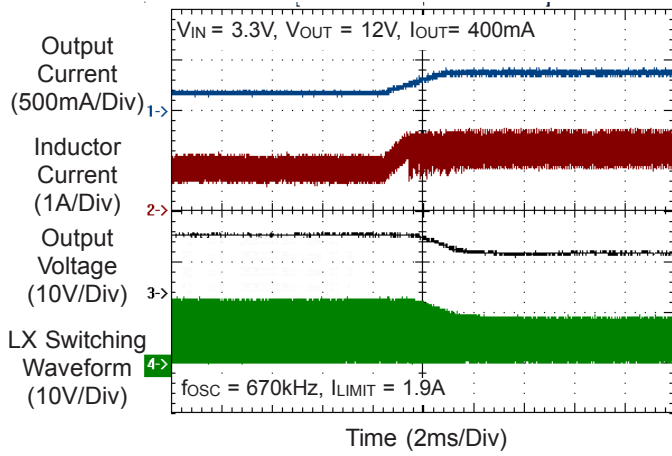

OTP Waveform

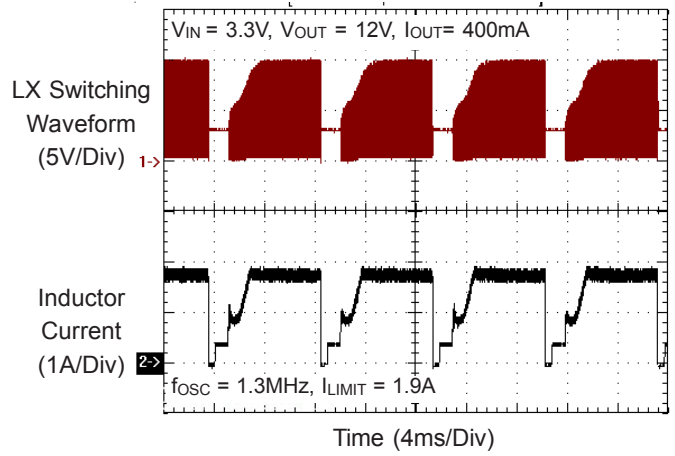

Maximum Output Current vs. Temperature

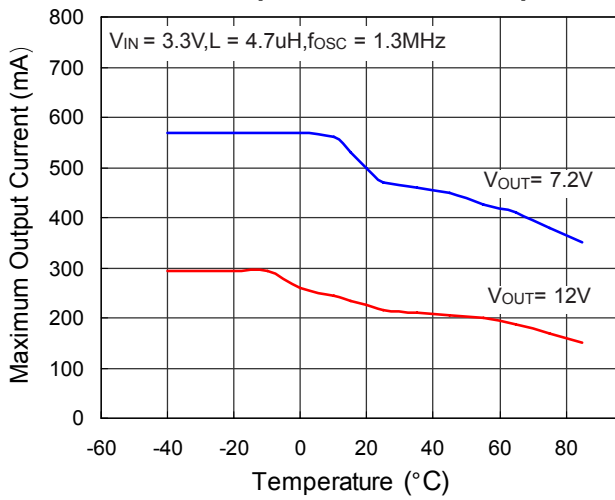

Component Selection Table

V _{IN} (V)	V _{OUT} (V)	f _{OSC} (Hz)	L1 (uH)	C2 (uF)	R3 (kΩ)	C3 (pF)	C4 (pF)	Typical I _{OUT(MAX)} (mA)
3.3	12	670k	10(TDK SLF6028)	33 tantalum	36	1200	33	250
3.3	12	670k	4.7(TDK SLF6028)	33 tantalum	47	1000	22	250
3.3	12	1.3M	10(TDK SLF6028)	33 tantalum	39	1000	33	210
3.3	12	1.3M	4.7(TDK SLF6028)	33 tantalum	51	820	22	210
3.3	7.2	670k	4.7(TDK SLF6028)	47 tantalum	22	820	56	490
3.3	7.2	1.3M	4.7(TDK SLF6028)	47 tantalum	32	1000	56	450

Application Information

The design procedure of Boost converter can start from the maximum input current, which is related about inductor, catch-diode, input/output capacitor selections and the maximum power which internal switch can stand. It can be derived from maximum output power, minimum input voltage and the efficiency of Boost converter. Once the maximum input current is calculated, the inductor value can be determined and the other components as well.

Inductor Selection

For a better efficiency in high switching frequency converter, the inductor selection has to use a proper core material such as ferrite core to reduce the core loss and choose low ESR wire to reduce copper loss. The most important point is to prevent the core saturated when handling the maximum peak current. Using a shielded inductor can minimize radiated noise in sensitive applications. The maximum peak inductor current is the maximum input current plus the half of inductor ripple current. The calculated peak current has to be smaller than the current limitation in the electrical characteristics. A typical setting of the inductor ripple current is 20% to 40% of the maximum input current. If the selection is 40%, the maximum peak inductor current is :

$$\begin{aligned}
 I_{PK} &= I_{IN(MAX)} + \frac{1}{2} I_{RIPPLE} = 1.2 \times I_{IN(MAX)} \\
 &= 1.2 \times \left[\frac{I_{OUT(MAX)} \times V_{OUT}}{\eta \times V_{IN(MIN)}} \right]
 \end{aligned}$$

The minimum inductance value is derived from the following equation :

$$L = \frac{\eta \times V_{IN(MIN)}^2 \times [V_{OUT} - V_{IN(MIN)}]}{0.4 \times I_{OUT(MAX)} \times V_{OUT}^2 \times f_{OSC}}$$

Depending on the application, the recommended inductor value is between 2.2uH and 10uH.

Diode Selection

To achieve high efficiency, Schottky diode is good choice for low forward drop voltage and fast switching time. The output diode rating should be able to handle the maximum output voltage, average power dissipation and the pulsating diode peak current.

Input Capacitor Selection

For better input bypassing, low-ESR ceramic capacitors are recommended for performance. A 10uF input capacitor is sufficient for most applications. For a lower output power requirement application, this value can be decreased.

Output Capacitor Selection

For lower output voltage ripple, low-ESR ceramic capacitors are recommended. The tantalum capacitors can be used as well, but the ESR is bigger than ceramic capacitor. The output voltage ripple consists of two components: one is the pulsating output ripple current flows through the ESR, and the other is the capacitive ripple caused by charging and discharging.

$$\begin{aligned} V_{\text{RIPPLE}} &= V_{\text{RIPPLE(ESR)}} + V_{\text{RIPPLE(C)}} \\ &\cong I_{\text{PEAK}} \times \text{ESR}_{\text{COUT}} + \frac{I_{\text{PEAK}}}{\text{COUT}} \left(\frac{V_{\text{OUT}} - V_{\text{IN}}}{V_{\text{OUT}} \times f_{\text{OSC}}} \right) \end{aligned}$$

Output Voltage

The regulated output voltage is calculated by :

$$V_{\text{OUT}} = 1.24\text{V} \times \left(1 + \frac{R1}{R2} \right)$$

For most applications, R2 is a suggested a value up to 100kΩ. Place the resistor-divider as close to the IC as possible to reduce the noise sensitivity.

Loop Compensation

The RT9270 voltage feedback loop can be compensated with an external compensation network consisted of R3, C3 and C4 (As shown in Figure 1). Choose R3 to set the high-frequency integrator gain for fast transient response without over or under compensation. Once R3 is determined, C3 is selected to set the integrator zero to maintain loop stability. The purpose of C4 is to cancel the zero caused by output capacitor and the capacitor ESR. If the ceramic capacitor is selected to be the output capacitor, C4 can be taken off because of the small ESR.

C2 is the output capacitor as shown in Figure 1. The following equations give approximate calculations of each component :

$$C3 = \frac{2}{C2 \times RL} \times 10^{-12} \text{ (F)}$$

$$R3 = \frac{V_O \times \sqrt{L1 \times C2}}{2 \times C3 \times V_{\text{IN}}} \text{ (}\Omega\text{)}$$

$$C4 = C2 \times \text{RESR} \times 1 \times 10^{-6} \text{ (F)}$$

The best criterion to optimize the loop compensation is by inspecting the transient response and adjusting the compensation network.

Soft-Start Capacitor

The soft-start function begins from $V_{\text{SS}}=0\text{V}$ to $V_{\text{SS}}=1.24\text{V}$ with a 4uA constant current charging to the soft-start capacitor, so the capacitor should be large enough to let the output voltage reach regulation inside the soft-start cycle. Typical value of soft-start capacitor range is from 10nF to 200nF. After the cycle finished, the load can start to draw maximum current as required.

Layout Guideline

For high frequency switching power supplies, the PCB layout is important step in system application design. In order to let IC achieve good regulation, high efficiency and stability, it is strongly recommended the power components should be placed as close as possible. These traces should be wide and short. The feedback pin and the networks of feedback and compensation should be kept away from the power loops, and be shielded with a ground trace or plane to prevent noise coupling.

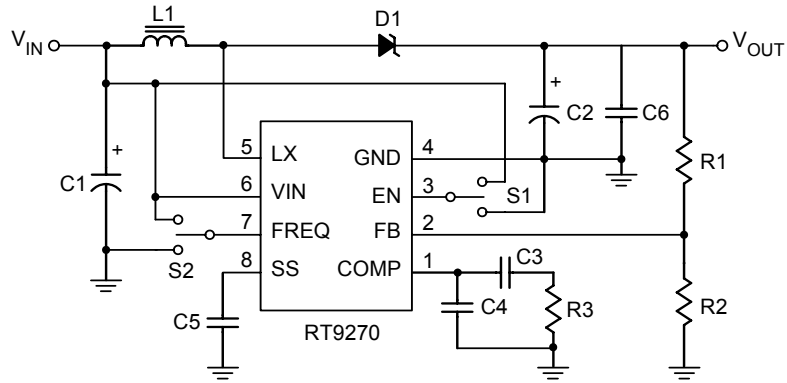

EVB Circuit

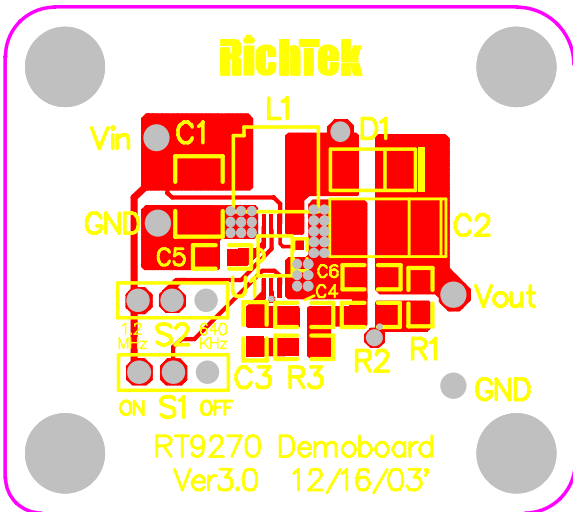

Top Side

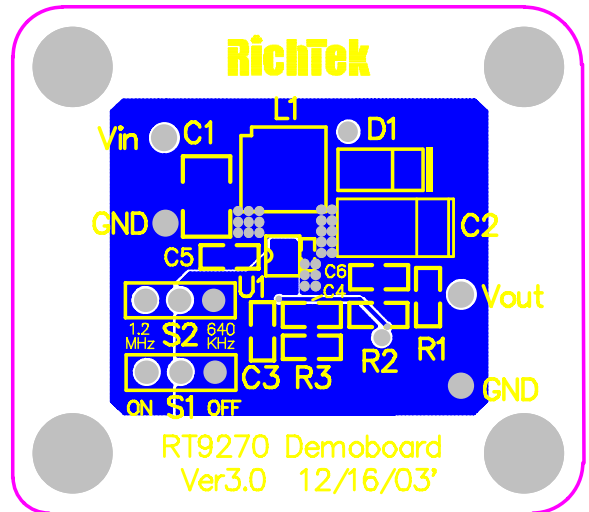

Bottom Side

Outline Dimension

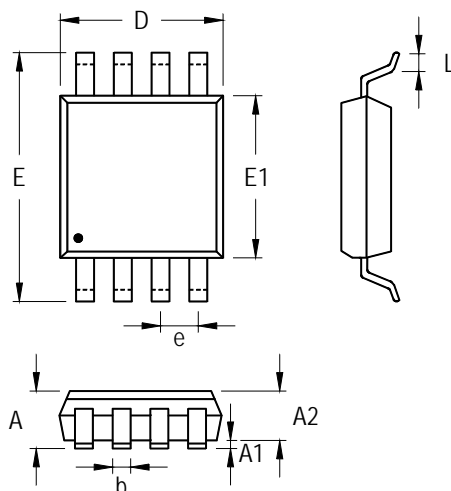

Symbol	Dimensions In Millimeters		Dimensions In Inches	
	Min	Max	Min	Max
A	0.810	1.100	0.032	0.043
A1	0.000	0.150	0.000	0.006
A2	0.750	0.950	0.030	0.037
b	0.220	0.380	0.009	0.015
D	2.900	3.100	0.114	0.122
e	0.650		0.026	
E	4.800	5.000	0.189	0.197
E1	2.900	3.100	0.114	0.122
L	0.400	0.800	0.016	0.031

8-Lead MSOP Plastic Package

Richtek Technology Corporation

Headquarter
 5F, No. 20, Taiyuen Street, Chupei City
 Hsinchu, Taiwan, R.O.C.
 Tel: (8863)5526789 Fax: (8863)5526611

Richtek Technology Corporation

Taipei Office (Marketing)
 8F, No. 137, Lane 235, Paochiao Road, Hsintien City
 Taipei County, Taiwan, R.O.C.
 Tel: (8862)89191466 Fax: (8862)89191465
 Email: marketing@richtek.com