

TPD1037BS

Low-Side Switch for Motor, Solenoid and Lamp Drive

TPD1037BS is a monolithic power IC for low-side switch.
 The IC has a vertical MOSFET output which can be directly driven from a CMOS or TTL logic circuit (e.g., an MPU).
 The IC offers intelligent self-protection functions.

Features

- A monolithic power IC with a new structure combining a control block and a vertical power MOSFET (π -MOS) on a single chip.
- Can directly drive a power load from a CMOS or TTL logic.
- Built-in protection circuits against overvoltage, overheat, and overcurrent.
- Low ON-resistance. $R_{DS(ON)} = 0.25 \Omega$ (max) (@ $V_{IN} = 5\text{ V}$, $T_j = 25^\circ\text{C}$)
- Package TO-92 (MOD) can be packed in tape.

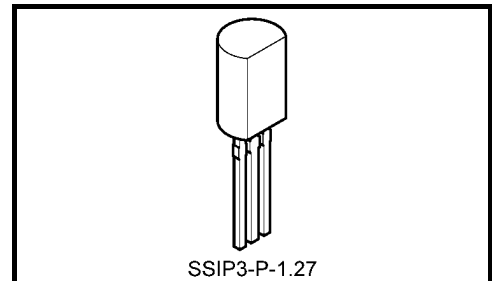

Weight: 0.36 g (typ.)

Pin Assignment

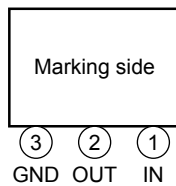

Note: That because of its MOS structure, this product is sensitive to static electricity.

Block Diagram

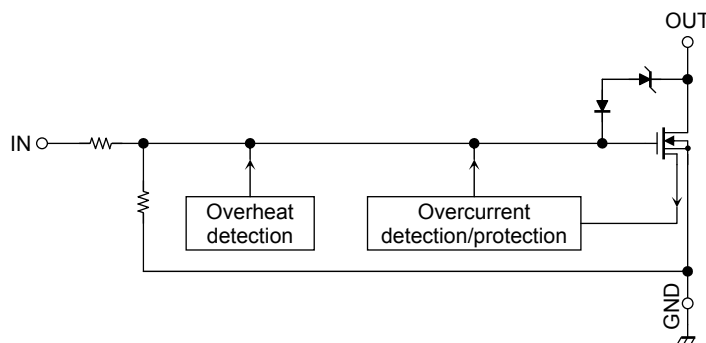

Pin Description

Pin No.	Symbol	Pin Description
1	IN	Input pin. This pin is connected to a pull-down resistor internally, so that even when input wiring is open-circuited, output can never be turned on inadvertently.
2	OUT	Output pin. If an inrush current flows (e.g., from a lamp), the current is clamped at 10 A (typ.) by an overcurrent protective circuit. Also, a 150 μs (typ.) mask circuit is included internally, so that if $V_{DS} \geq 12$ V (typ.) after this mask time, the current is clamped at 3 A (typ.)
3	GND	Ground pin.

Timing Chart

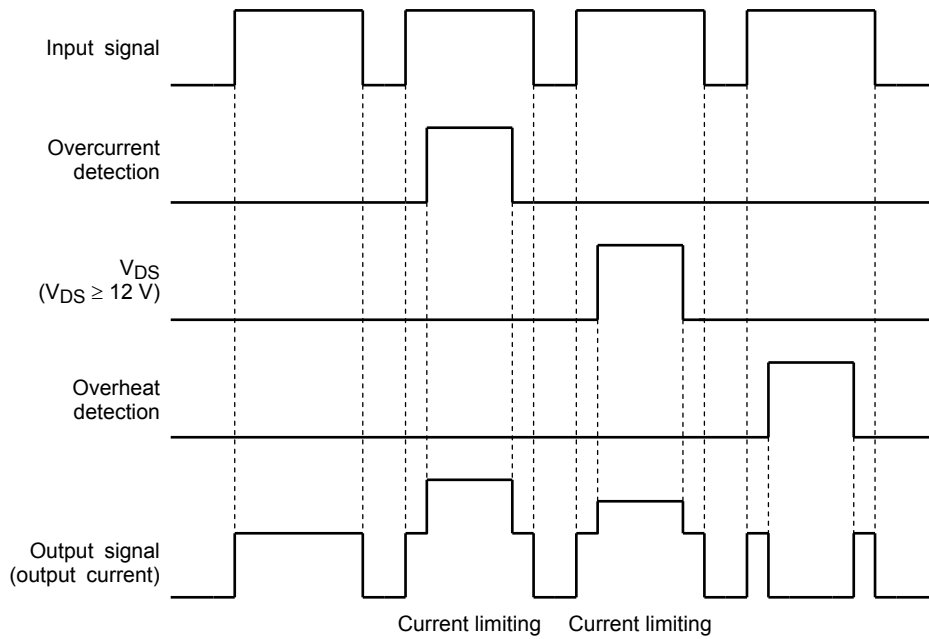

Truth Table

IN	V _{OUT}	Mode
L	H	Normal
H	L	
L	H	Overcurrent (during inrush)
H	L	
L	H	Overcurrent (shorted load)
H	L	
L	H	Overheat
H	H	

Absolute Maximum Ratings (Ta = 25°C)

Characteristics	Symbol	Rating	Unit
Drain-source voltage	V _{DS} (DC)	40	V
Output current	I _D	1.5	A
Input voltage	V _{IN}	-0.5 to 6	V
Power dissipation (Ta = 25°C)	P _D	0.9	W
Energy tolerance	ES/B	200	mJ
Operating temperature	T _{opr}	-40 to 85	°C
Junction temperature	T _j	150	°C

Note: Using continuously under heavy loads (e.g. the application of high temperature/current/voltage and the significant change in temperature, etc.) may cause this product to decrease in the reliability significantly even if the operating conditions (i.e. operating temperature/current/voltage, etc.) are within the absolute maximum ratings and the operating ranges.

Please design the appropriate reliability upon reviewing the Toshiba Semiconductor Reliability Handbook ("Handling Precautions"/Derating Concept and Methods) and individual reliability data (i.e. reliability test report and estimated failure rate, etc).

Electrical Characteristics (T_j = 25°C)

Characteristics	Symbol	Test Circuit	Test Condition	Min	Typ.	Max	Unit
Drain-source breakdown voltage	V _{(BR)DSS}	—	V _{IN} = 0 V, I _D = 10 mA	40	—	—	V
High level input voltage	V _{IH}	—	V _{DS} = 10 to 40 V, I _D = 1 A	3.5	5	6	V
Low level input voltage	V _{IL}	—	V _{DS} = 10 to 40 V, I _D = 10 μA	—	—	0.8	V
Current at output OFF	I _{DSS} (1)	—	V _{IN} = 0 V, V _{DS} = 40 V	—	—	100	μA
	I _{DSS} (2)		V _{IN} = 0 V, V _{DS} = 24 V	—	—	10	
Input current	I _{IN}	—	V _{IN} = 5 V, at normal operation	—	—	300	μA
ON-resistance	R _{DS(ON)}	—	V _{IN} = 5 V, I _D = 1 A	—	—	0.25	Ω
Overheat protection	T _S	—	V _{IN} = 5 V	—	160	—	°C
Overcurrent protection	I _S (1)	—	V _{DS} = 24 V, V _{IN} = 5 V, during inrush	—	10	—	A
	I _S (2)		V _{DS} = 24 V, V _{IN} = 5 V, when shorted load	—	3	—	
Shorted load detection voltage	V _{DS}	—	when shorted load	—	12	—	V
Switching time	t _{ON}	1	V _{DS} = 24 V, V _{IN} = 5 V, R _L = 24 Ω	—	70	—	μs
	t _{OFF}			—	120	—	
Diode forward voltage between drain and source	V _{D_{SF}}	—	I _F = 1.5 A	—	0.9	1.8	V

Test Circuit 1

Switching Time Measuring Circuit

Test Circuit

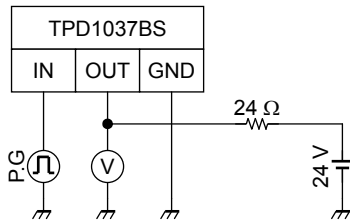

Measured Waveforms

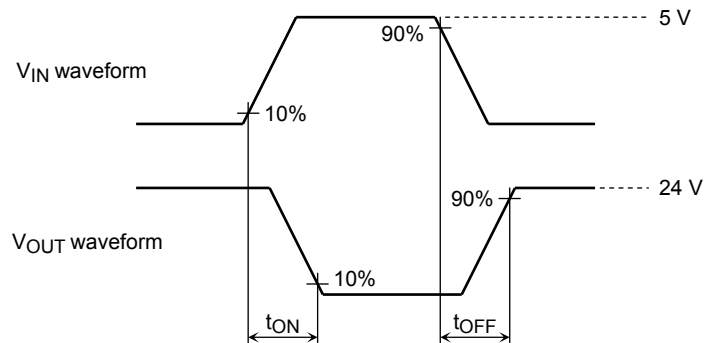

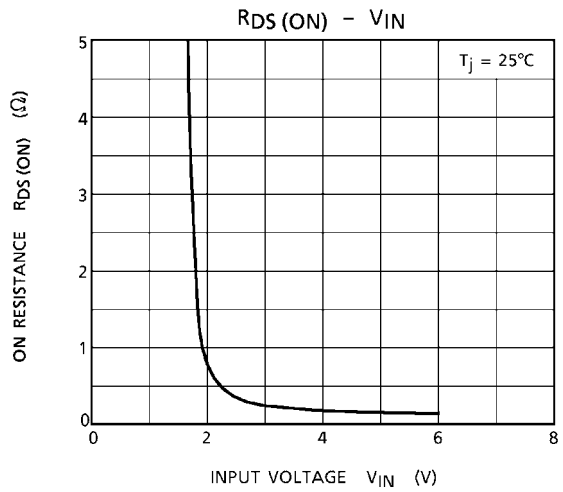
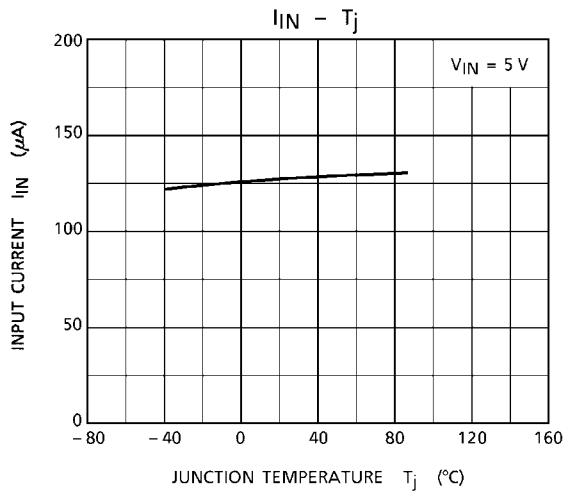
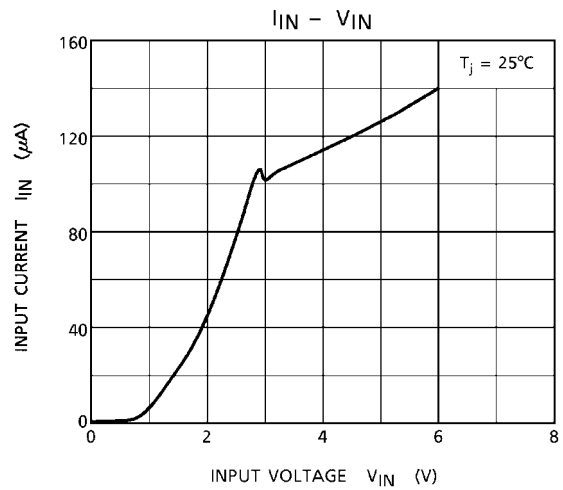
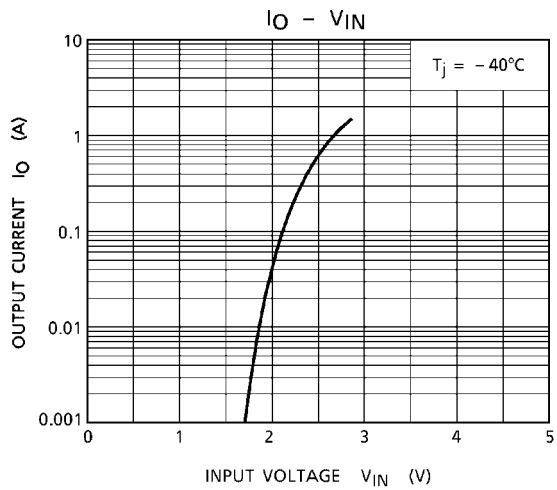
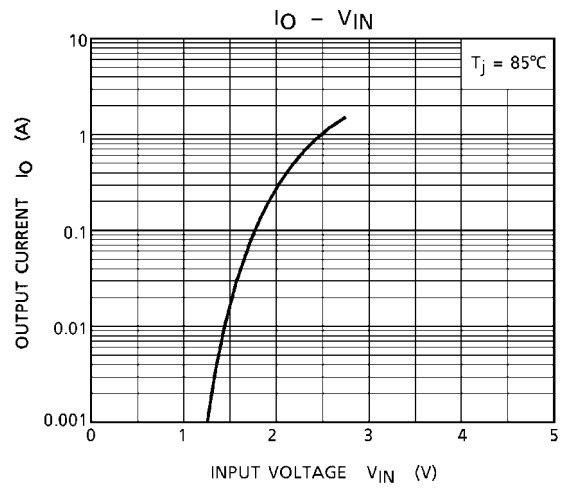
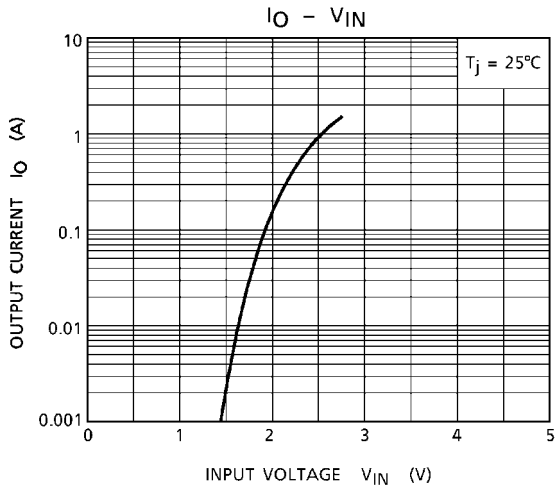

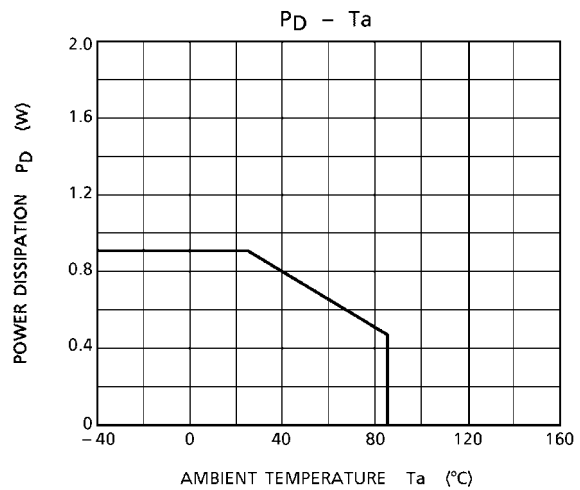
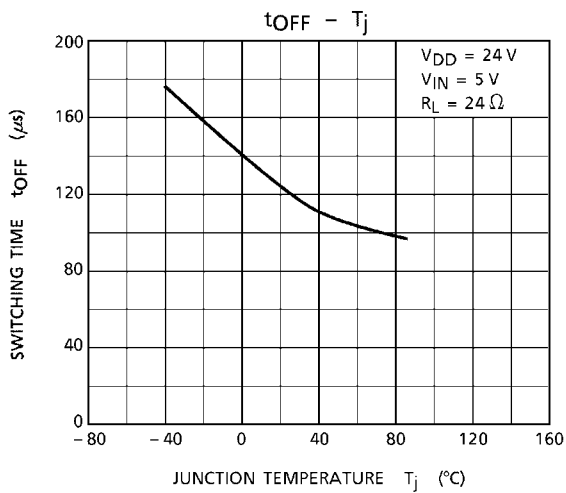
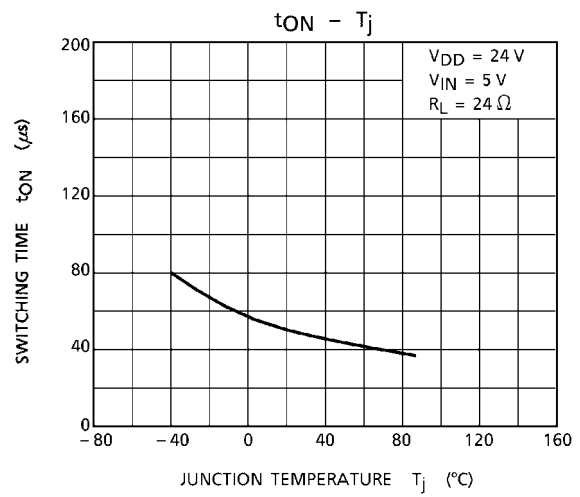
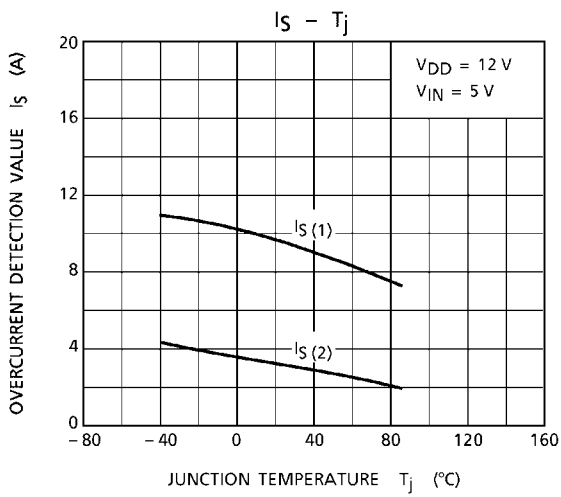
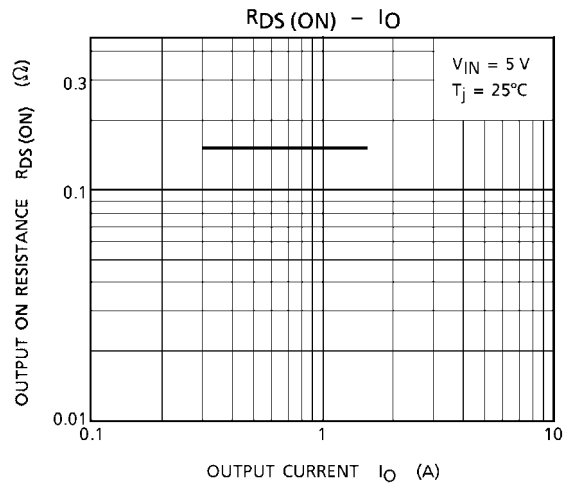
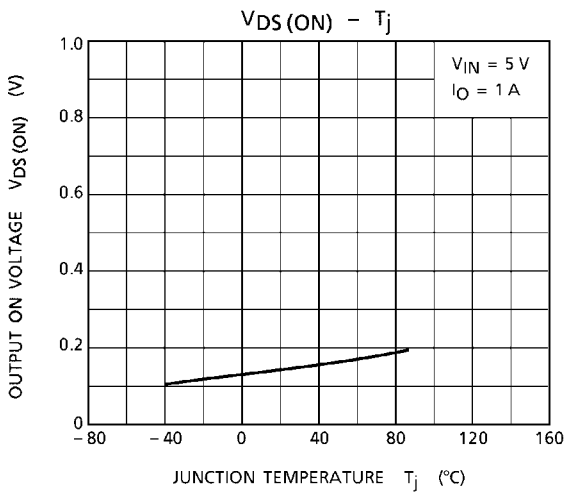

Package Dimensions

SSIP3-P-1.27

Unit : mm

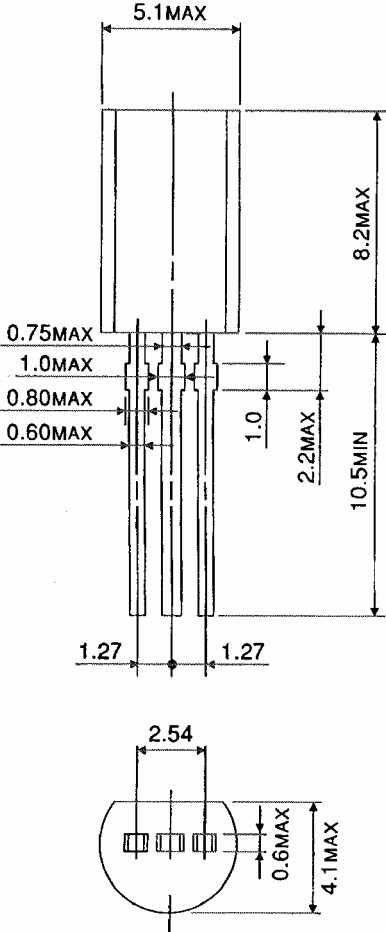

Weight: 0.36 g (typ.)

RESTRICTIONS ON PRODUCT USE

20070701-EN

- The information contained herein is subject to change without notice.
- TOSHIBA is continually working to improve the quality and reliability of its products. Nevertheless, semiconductor devices in general can malfunction or fail due to their inherent electrical sensitivity and vulnerability to physical stress. It is the responsibility of the buyer, when utilizing TOSHIBA products, to comply with the standards of safety in making a safe design for the entire system, and to avoid situations in which a malfunction or failure of such TOSHIBA products could cause loss of human life, bodily injury or damage to property.
In developing your designs, please ensure that TOSHIBA products are used within specified operating ranges as set forth in the most recent TOSHIBA products specifications. Also, please keep in mind the precautions and conditions set forth in the "Handling Guide for Semiconductor Devices," or "TOSHIBA Semiconductor Reliability Handbook" etc.
- The TOSHIBA products listed in this document are intended for usage in general electronics applications (computer, personal equipment, office equipment, measuring equipment, industrial robotics, domestic appliances, etc.). These TOSHIBA products are neither intended nor warranted for usage in equipment that requires extraordinarily high quality and/or reliability or a malfunction or failure of which may cause loss of human life or bodily injury ("Unintended Usage"). Unintended Usage include atomic energy control instruments, airplane or spaceship instruments, transportation instruments, traffic signal instruments, combustion control instruments, medical instruments, all types of safety devices, etc.. Unintended Usage of TOSHIBA products listed in this document shall be made at the customer's own risk.
- The products described in this document shall not be used or embedded to any downstream products of which manufacture, use and/or sale are prohibited under any applicable laws and regulations.
- Please contact your sales representative for product-by-product details in this document regarding RoHS compatibility. Please use these products in this document in compliance with all applicable laws and regulations that regulate the inclusion or use of controlled substances. Toshiba assumes no liability for damage or losses occurring as a result of noncompliance with applicable laws and regulations.