

10/100Base-TX Interface PCMCIA Module EPF8209S



- Designed to work with Broadcom BCM5201, BCM5221 Chipsets
- Complies with or exceeds IEEE 802.3, 10/100Base-TX Standards
- Robust design allows for toughest soldering processes
- 1500 Vrms Isolation

Electrical Parameters @ 25° C

OCL (μ H Min.) @ 8 mA DC Bias	Interwinding Capacitance (pF Max.)	Leakage Inductance (μ H Max.)	CMRR (dB Min.)					Return Loss (dB Min.)			Primary DCR (Ω Max.)	
			1 MHz	30 MHz	60 MHz	80 MHz	100 MHz	1-30 MHz	30-60 MHz	60-80 MHz	Xmit	Rcv
100 KHz, 0.1 Vrms	@ 100 KHz, 0.1 Vrms	@ 100 KHz, 0.1 Vrms	Xmit/Rcv	Xmit/Rcv	Xmit/Rcv	Xmit/Rcv	Xmit/Rcv	Xmit & Rcv			Xmit	Rcv
350 @ Pins 16-15 & 10-9	25	0.3	-27/-27	-17/-9	-16/-4	-14/-2	-12/-1	-10	-14	-10	1.5	1.0

• Insertion Loss : -1 dB Max., 1 MHz to 100 MHz •

Schematic

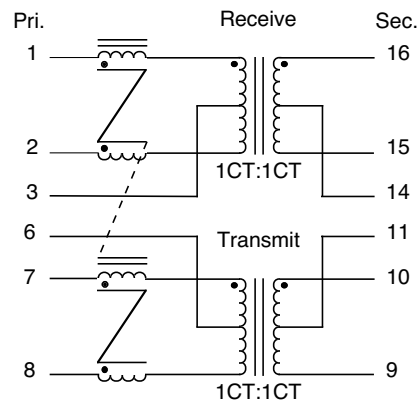

Package

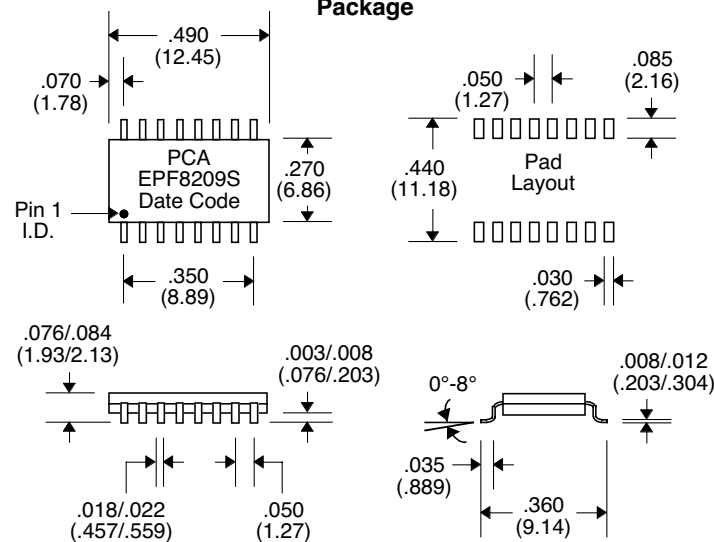

Unless Otherwise Specified Dimensions are in Inches /mm \pm .010 / .25