



DATA SHEET

ER200~ER206

SUPERFAST RECOVERY RECTIFIERS

VOLTAGE 50 to 600 Volts **CURRENT** 2.0 Ampere

DO-15 Unit: inch(mm)

FEATURES

- Superfast recovery times-epitaxial construction.
- Low forward voltage, high current capability.
- Exceeds environmental standards of MIL-S-19500/228.
- Hermetically sealed.
- Low leakage.
- High surge capability.
- Plastic package has Underwriters Laboratories Flammability Classification 94V-O utilizing Flame Retardant Epoxy Molding Compound.
- Pb free product are available : 99% Sn above can meet Rohs environment substance directive request

MECHANICAL DATA

Case: Molded plastic, DO-15
 Terminals: Axial leads, solderable to MIL-STD-202G, Method 208
 Polarity: Color Band denotes cathode end
 Mounting Position: Any
 Weight: 0.015 ounce, 0.4 gram

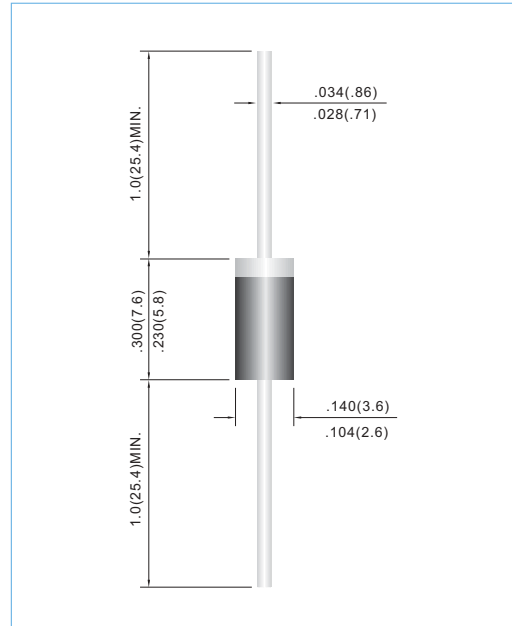

MAXIMUM RATINGS AND ELECTRICAL CHARACTERISTICS

Ratings at 25°C ambient temperature unless otherwise specified. Resistive or inductive load, 60Hz.

PARAMETER	SYMBOL	ER200	ER201	ER201A	ER202	ER203	ER204	ER206	UNITS
Maximum Recurrent Peak Reverse Voltage	V_{RRM}	50	100	150	200	300	400	600	V
Maximum RMS Voltage	V_{RMS}	35	70	105	140	210	280	420	V
Maximum DC Blocking Voltage	V_{DC}	50	100	150	200	300	400	600	V
Maximum Average Forward Current .375"(9.5mm) lead length at $T_A=55^\circ C$	I_{AV}	2.0							A
Peak Forward Surge Current : 8.3ms single half sine-wave superimposed on rated load(JEDEC method)	I_{FSM}	50							A
Maximum Forward Voltage at 2.0A	V_F	0.95				1.25		1.70	V
Maximum DC Reverse Current $T_A=25^\circ C$ at Rated DC Blocking Voltage $T_A=125^\circ C$	I_R					5.0		200	μA
Maximum Reverse Recovery Time(Note 1)	T_{RR}					35			ns
Typical Junction capacitance (Note 2)	C_J					22			pF
Typical Junction Resistance(Note 3)	$R_{\theta JA}$					40			$^\circ C / W$
Operating and Storage Temperature Range	T_J, T_{STG}	-55 TO +150							$^\circ C$

NOTES: 1. Reverse Recovery Test Conditions: $I_F=.5A$, $I_R=1A$, $I_{rr}=.25A$
 2. Measured at 1 MHz and applied reverse voltage of 4.0 VDC
 3. Thermal resistance from junction to ambient and from junction to lead length 0.375"(9.5mm) P.C.B. mounted



RATING AND CHARACTERISTIC CURVES

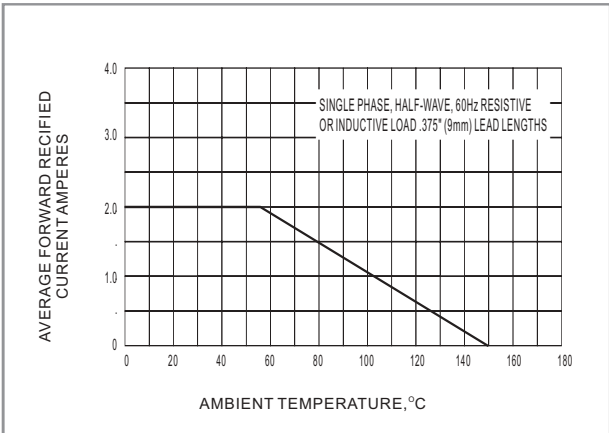

FIG.1 MAXIMUM AVERAGE FORWARD CURRENT RATING

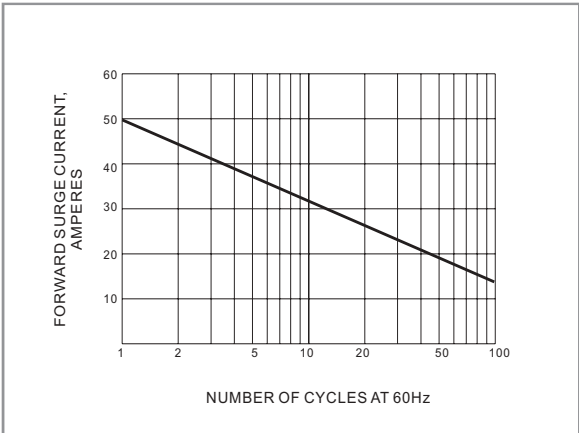

FIG.2 MAXIMUM NON-REPEITIVE SURGE CURRENT

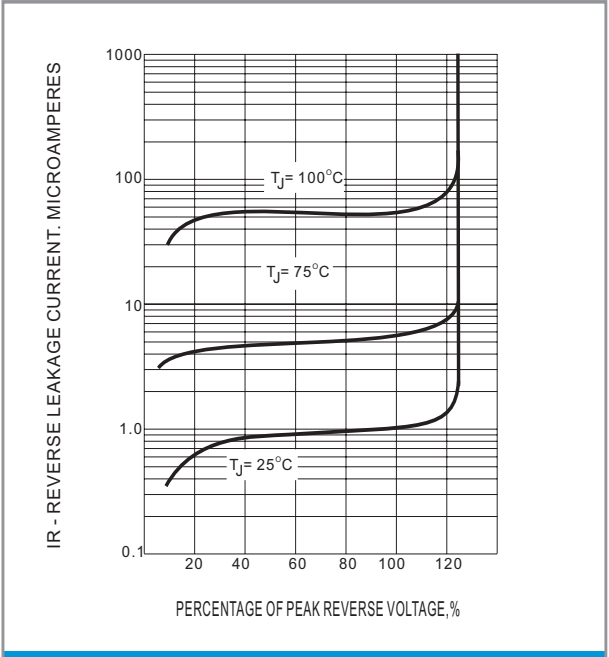

FIG.3 TYPICAL REVERSE CHARACTERISTICS

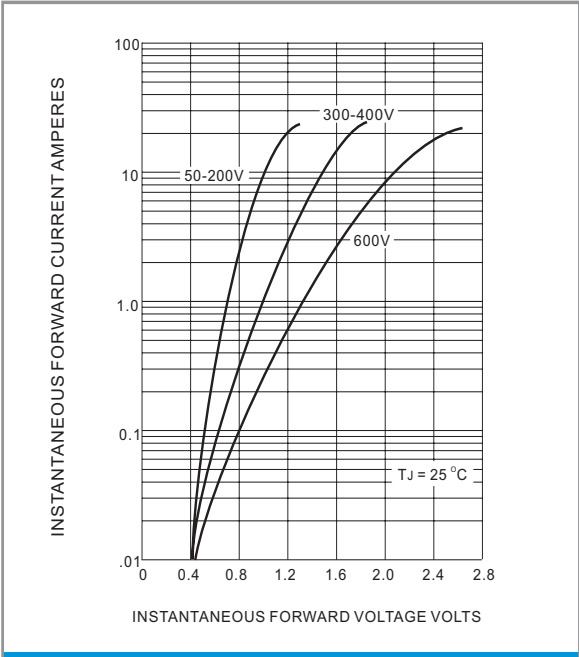

FIG.4 TYPICAL FORWARD CHARACTERISTICS

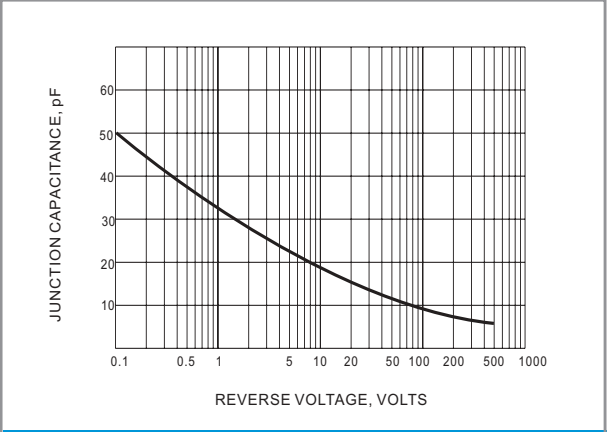

FIG.5 TYPICAL JUNCTION CAPACITANCE