

ARINC 429 Bus Interface Line Driver Circuit

The HS-3182 is a monolithic dielectrically isolated bipolar differential line driver designed to meet the specifications of ARINC 429. This Device is intended to be used with a companion chip, HS-3282 CMOS ARINC Bus Interface Circuit, which provides the data formatting and processor interface function.

All logic inputs are TTL and CMOS compatible. In addition to the DATA (A) and DATA (B) inputs, there are also inputs for CLOCK and SYNC signals which are AND'd with the DATA inputs. This feature enhances system performance and allows the HS-3182 to be used with devices other than the HS-3182.

Three power supplies are necessary to operate the HS-3182: +V = +15V ±10%, -V = -15V ±10%, and V1 = 5V ±5%. V_{REF} is used to program the differential output voltage swing such that V_{OUT} (DIFF) = ±2V_{REF}. Typically, V_{REF} = V1 = 5V ±5%, but a separate power supply may be used for VREF which should not exceed 6V.

The driver output impedance is 75Ω ±20% at +25°C. Driver output rise and fall times are independently programmed through the use of two external capacitors connected to the CA and CB inputs. Typical capacitor values are CA = CB = 75pF for high-speed operation (100kBPS), and CA = CB = 300pF for low-speed operation (12kBPS to 14.5kBPS). The outputs are protected against overvoltage and short circuit as shown in the Block Diagram. The HS-3182 is designed to operate over an ambient temperature range of -55°C to +125°C, or -40°C to +85°C.

TABLE 1. TRUTH TABLE

| SYNC | CLK | DATA (A) | DATA (B) | A _{OUT} | B _{OUT} | COMMENTS |
|------|-----|----------|----------|-------------------|-------------------|----------|
| X | L | X | X | 0V | 0V | Null |
| L | X | X | X | 0V | 0V | Null |
| H | H | L | L | 0V | 0V | Null |
| H | H | L | H | -V _{REF} | +V _{REF} | Low |
| H | H | H | L | +V _{REF} | -V _{REF} | High |
| H | H | H | H | 0V | 0V | Null |

Features

- RoHS/Pb-free Available for SBDIP Package (100% Gold Termination Finish)
- TTL and CMOS Compatible Inputs
- Adjustable Rise and Fall Times via Two External Capacitors
- Programmable Output Differential Voltage via VREF Input
- Operates at Data Rates Up to 100k Bits/s
- Output Short Circuit Proof and Contains Overvoltage Protection
- Outputs are Inhibited (0V) If DATA (A) and DATA (B) Inputs are Both in the "Logic One" State
- DATA (A) and DATA (B) Signals are "AND'd" with Clock and Sync Signals
- Full Military Temperature Range

Pinouts

**HS-3182
(16 LD SBDIP)
TOP VIEW**

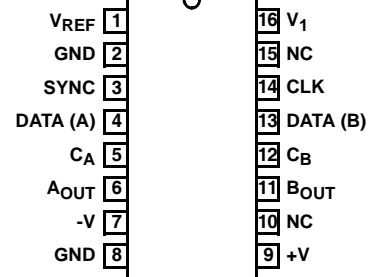

**HS-3182
(28 LD CLCC)
TOP VIEW**

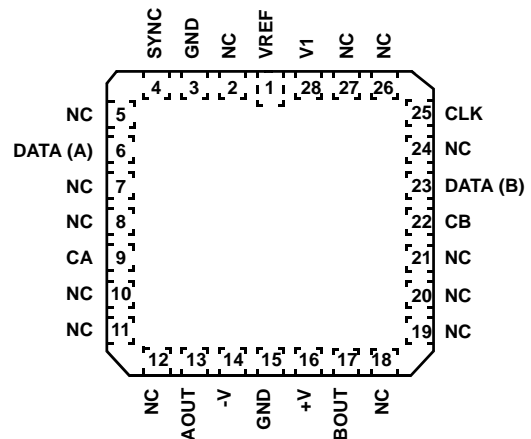

Ordering Information

| PART NUMBER | ORDERING NUMBER | PART MARKING | TEMP. RANGE (°C) | PACKAGE | PKG. DWG. # |
|-------------|-----------------|----------------|------------------|------------------------------------|-------------|
| HS1-3182-8 | 5962-8687901EA | HS1-3182-8 RD | -55 to +125 | 16 Ld SBDIP, Solder Seal (Pb-free) | D16.3 |
| HS1-3182-9+ | HS1-3182-9+ | HS1-3182-9+ RD | -40 to +85 | 16 Ld SBDIP, Solder Seal (Pb-free) | D16.3 |
| HS4-3182-8 | 5962-86879013A | HS4- 3182-8 RD | -55 to +125 | 28 Ld TER CLCC, Solder Seal | J28.A |

Block Diagram

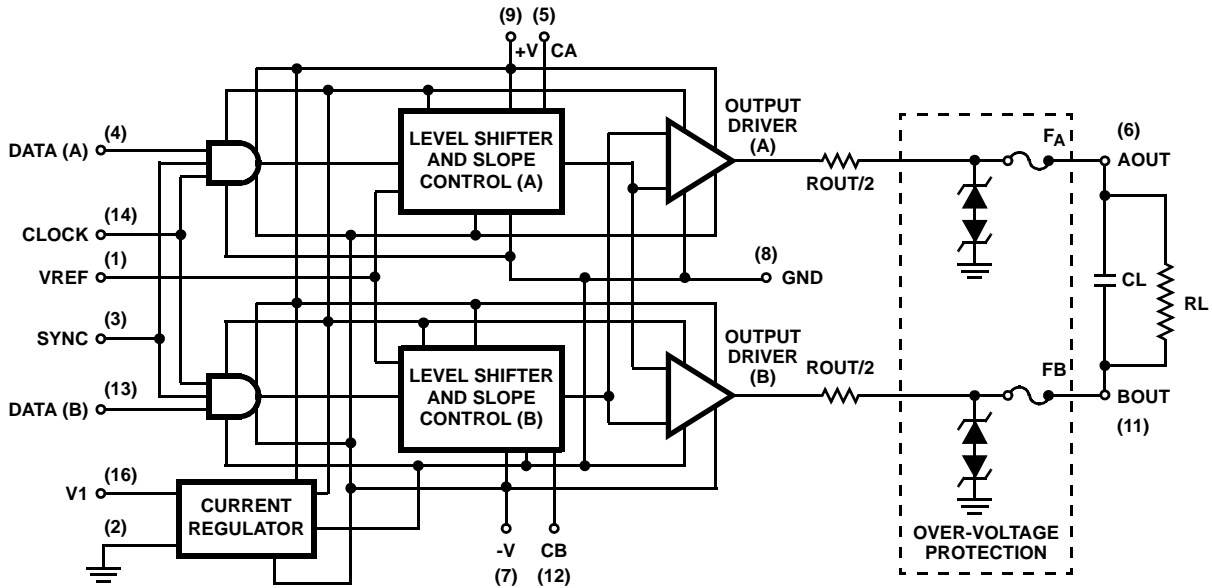

Typical Application

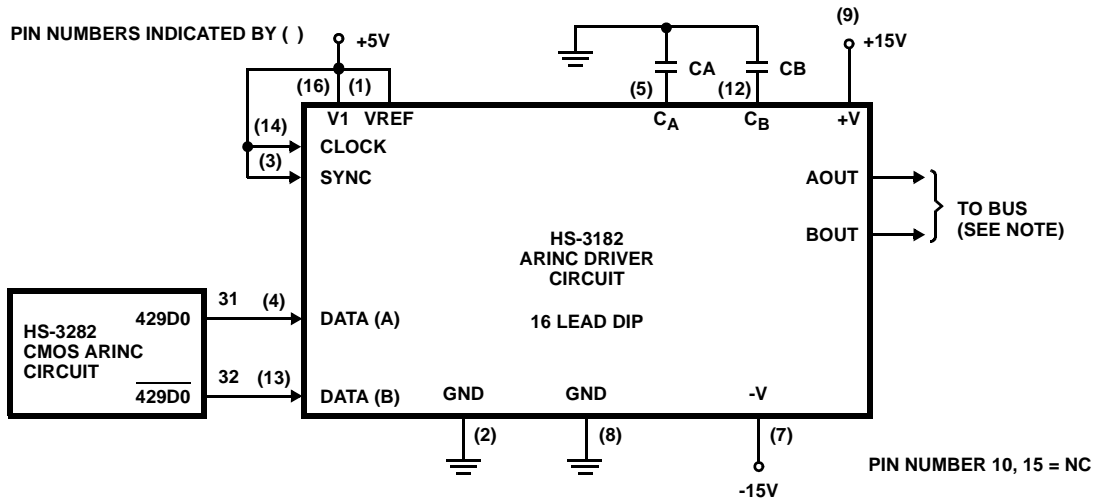

NOTE: The rise and fall time of the outputs are set to ARINC specified values by C_A and C_B . Typical $C_A = C_B = 75\text{pF}$ for high speed and 300pF for low speed operation. The output HI and low levels are set to ARINC specifications by V_{REF} .

Absolute Maximum Ratings

| | |
|-------------------------------------|-----------------------|
| Voltage Between +V and -V Terminals | .40V |
| V1 | .7V |
| VREF | .6V |
| Logic Input Voltage | GND -0.3V to V1 +0.3V |
| ESD Classification | Class 1 |
| Output Short Circuit Duration | (Note 1) |
| Output Over-Voltage Protection | (Note 2) |

Operating Conditions

| | |
|-----------------------------|-----------------|
| Operating Voltage | |
| +V | +15V ±10% |
| -V | -15V ±10% |
| V1 | 5V ±5% |
| VREF (For ARINC 429) | 5V ±5% |
| Operating Temperature Range | |
| HS-3182-9+ | -40°C to +85°C |
| HS-3182-8 | -55°C to +125°C |

Thermal Information

| | | |
|------------------------------|---|----------------------|
| Thermal Resistance (Typical) | θ_{JA} (°C/W) | θ_{JC} (°C/W) |
| SBDIP Package | 75 | 18 |
| CLCC Package | 60 | 14 |
| Storage Temperature Range | -65°C to +150°C | |
| Maximum Junction Temperature | +175°C | |
| Pb-free reflow profile | see link below | |
| | http://www.intersil.com/pbfree/Pb-FreeReflow.asp | |

Die Characteristics

| | |
|--------------------------------|-----|
| Number of Transistors or Gates | 133 |
|--------------------------------|-----|

CAUTION: Stresses above those listed in the "Absolute Maximum Ratings" may cause permanent damage to the device. Extended operation above recommended operating conditions could result in decreased reliability. The Absolute Maximum Ratings are stress only ratings and operation of the device at these or any other conditions above those indicated in the operational sections of this specification is not implied."

NOTE:

- Heat sink may be required for 100k bits/s at +125°C and output short circuit at +125°C.
- The fuses used for output overvoltage protection may be blown by a fault at each output of greater than ±6.5V relative to GND.

DC Electrical Specifications

| DC PARAMETER | SYMBOL | (NOTE 3) CONDITIONS | MIN | MAX | UNITS |
|---|---------------------------------------|-----------------------------|-------------------------------|-------------------------------|-------|
| Supply Current +V (Operating) | I _{CCOP} (+V) | No Load (0k to 100k bits/s) | - | 16 | mA |
| Supply Current -V (Operating) | I _{CCOP} (-V) | No Load (0k to 100k bits/s) | -16 | - | mA |
| Supply Current V ₁ (Operating) | I _{CCOP} (V ₁) | No Load (0k to 100k bits/s) | - | 975 | mA |
| Supply Current V _{REF} (Operating) | I _{CCOP} (V _{REF}) | No Load (0k to 100k bits/s) | -1.0 | - | mA |
| Logic "1" Input Voltage | V _{IH} | | 2.0 | - | V |
| Logic "0" Input Voltage | V _{IL} | | - | 0.5 | V |
| Output Voltage High (Output to GND) | V _{OH} | No Load (0k to 100k bits/s) | V _{REF} (-250mV) | V _{REF} (+250mV) | |
| Output Voltage Low (Output to GND) | V _{OL} | No Load (0k to 100k bits/s) | -V _{REF} (-250mV) | -V _{REF} (+250mV) | |
| Output Voltage Null | V _{NULL} | No Load (0k to 100k bits/s) | -250 | +250 | mV |
| Input Current (Input Low) | I _{IL} | | -20 | - | mA |
| Input Current (Input High) | I _{IH} | | - | 10 | mA |
| Output Short Circuit Current (Output High) | I _{OHSC} | Short to GND | - | -80 | mA |
| Output Short Circuit Current (Output Low) | I _{OLSC} | Short to GND | 80 | - | mA |
| Output Impedance | Z _O | T _A = +25°C | 60 | 90 | Ω |

NOTE:

- +V = +15V ±10%, -V = -15V ±10%, V₁ = V_{REF} = 5V ±5%, unless otherwise specified T_A = -40°C to +85°C for HS-3182-9+ and T_A = -55°C to +125°C for HS-3182-8.

AC Electrical Specifications

| AC PARAMETER | SYMBOL | (NOTE 4) CONDITIONS | MIN | MAX | UNITS |
|--|------------------|---|-----|-----|-------|
| Rise Time (A _{OUT} , B _{OUT}) | t _R | C _A = C _B = 75pF, Note 5 | 1 | 2 | μS |
| | | (at T _A = -55°C Only) | 0.9 | 2.4 | μS |
| | | C _A = C _B = 300pF, Note 5 | 3 | 9 | μS |
| Fall Time (A _{OUT} , B _{OUT}) | t _F | C _A = C _B = 75pF, Note 6 | 1 | 2 | μS |
| | | (at T _A = -55°C Only) | 0.9 | 2.4 | μS |
| | | C _A = C _B = 300pF, Note 6 | 3 | 9 | μS |
| Propagation Delay Input to Output | t _{PLH} | C _A = C _B = 75pF, No Load | - | 3.3 | μS |
| Propagation Delay Input to Output | t _{PHL} | C _A = C _B = 75pF, No Load | - | 3.3 | μS |

NOTES:

- +V = +15V, -V = -15V, V₁ = V_{REF} = 5V, unless otherwise specified T_A = -40°C to +85°C for HS-3182-9+ and T_A = -55°C to +125°C for HS-3182-8.
- t_R measured 50% to 90% x 2, no load.
- t_F measured 50% to 10% x 2, no load.

Electrical Specifications

| PARAMETER | SYMBOL | (NOTE 7) CONDITIONS | MIN | MAX | UNITS |
|-----------------------------------|----------------------|--------------------------------------|------|-----|-------|
| Input Capacitance | C _{IN} | T _A = +25°C | - | 15 | pF |
| Supply Current +V (Short Circuit) | I _{SC} (+V) | Short to GND, T _A = +25°C | - | 150 | mA |
| Supply Current -V (Short Circuit) | I _{SC} (-V) | Short to GND, T _A = +25°C | -150 | - | mA |

NOTE:

- The parameters listed in Table 3 are controlled via design or process parameters and are not directly tested. These parameters are characterized upon initial design and after major process and/or design changes affecting these parameters.

Power Specifications

Nominal Power at +25°C, +V = +15V, -V = -15V, V₁ = V_{REF} = 5V, Notes 8, 10

| DATA RATE (k BITS/s) | LOAD | +V | V- | V ₁ | CHIP POWER | POWER DISSIPATION IN LOAD |
|-------------------------|-------------------|------|-------|----------------|------------|------------------------------|
| 0 to 100 | No Load | 11mA | -10mA | 600μA | 325mW | 0 |
| 12.5 to 14 | Full Load, Note 9 | 24mW | -24mW | 600μA | 660mW | 60mW |
| 100 | Full Load, Note 9 | 46mW | -46mW | 600μA | 1 Watt | 325mW |

NOTES:

- Heat sink may be required for 100k bits/s at +125°C and output short circuit at +125°C.

Thermal characteristics: T_(CASE) = T_(Junction) - θ_(Junction - Case) P_(Dissipation)

Where: T_(Junction Max) = +175°C

θ_(Junction - Case) = 10.9°C/W (6.1°C/W for LCC)

θ_(Junction - Ambient) = 73.5°C/W (54.0°C/W for LCC)

- Full Load for ARINC 429: R_L = 400Ω and C_L = 30,000pF in parallel between A_{OUT} and B_{OUT} (See “Block Diagram” on page 2).

- Output Overvoltage Protection: The fuses used for output overvoltage protection may be blown by a fault at each output of greater than ±6.5V relative to GND.

Driver Waveforms

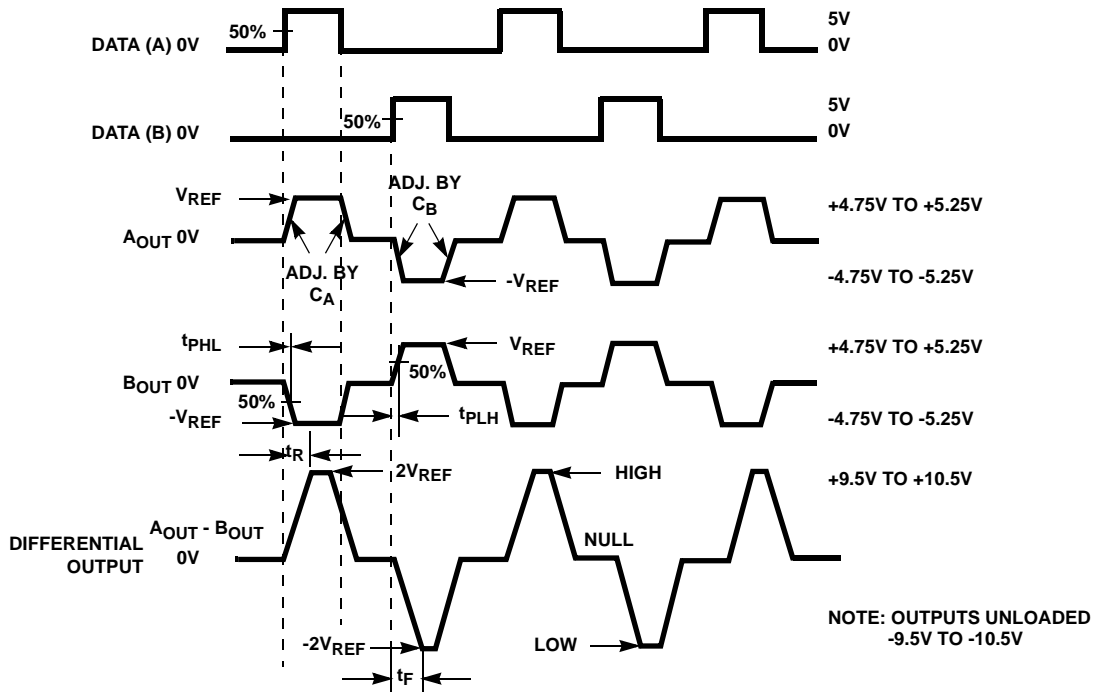

NOTES:

- t_R measured 50% to 90% times 2
- t_F measured 50% to 10% times 2
- V_{IH} = 5V V_{OL} = -4.75V to -5.25V
- V_{IL} = 0V V_{OH} = 4.75V to 5.25V

When the Data (A) input is in the Logic One state and the Data (B) input is in the Logic Zero state, A_{OUT} is equal to V_{REF} and B_{OUT} is equal to -V_{REF}. This constitutes the Output High state. Data (A) and Data (B) both in the Logic Zero state causes both A_{OUT} and B_{OUT} to be equal to 0V which designates the output Null state. Data (A) in the Logic Zero state and Data (B) in the Logic One state causes A_{OUT} to be equal to -V_{REF} and B_{OUT} to be equal to V_{REF} which is the Output Low state.

Burn-In Schematic

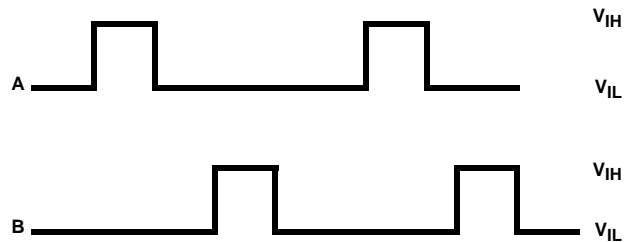
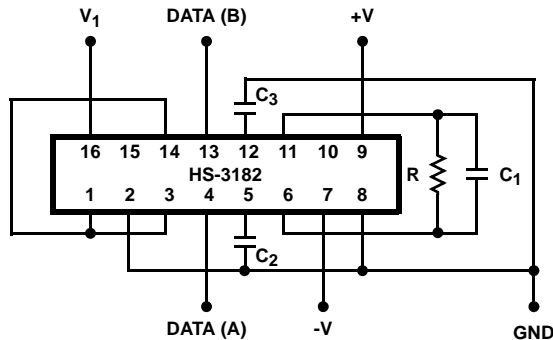

NOTES:

- R = 400Ω ± 5%
- C₁ = 0.03mF ± 20%
- C₂ = C₃ = 500pF, NPO
- +V = +15.5V ± 0.5V
- V = -15.5V ± 0.5V
- V₁ = +5.5V ± 0.5V
- A 0.0mF decoupling capacitor is required on each of the three supply lines (+V, -V and V₁) at every 3rd Burn-In socket.

- Ambient Temp. Max. = +125°C.
- Package = 16 Lead Side Brazed DIP.
- Pulse Conditions = A & B = 6.25kHz ±10%. B is delayed one-half cycle and in sync with A.
- V_{IH} = 2.0V Min.
- V_{IL} = 0.5V Max.

Ceramic Leadless Chip Carrier Packages (CLCC)

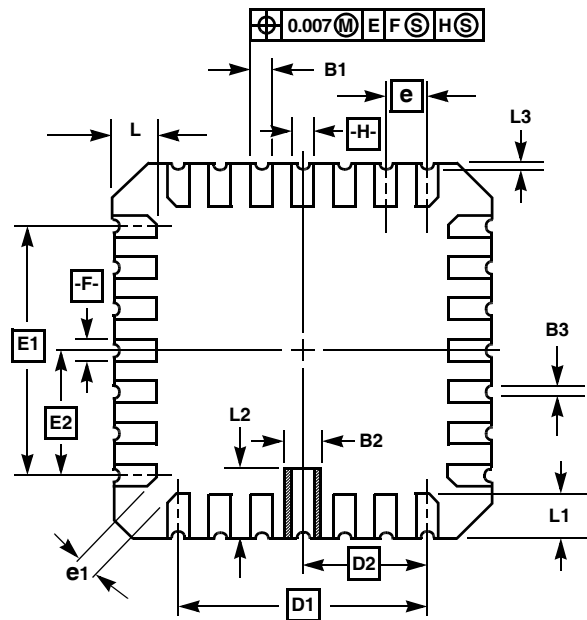
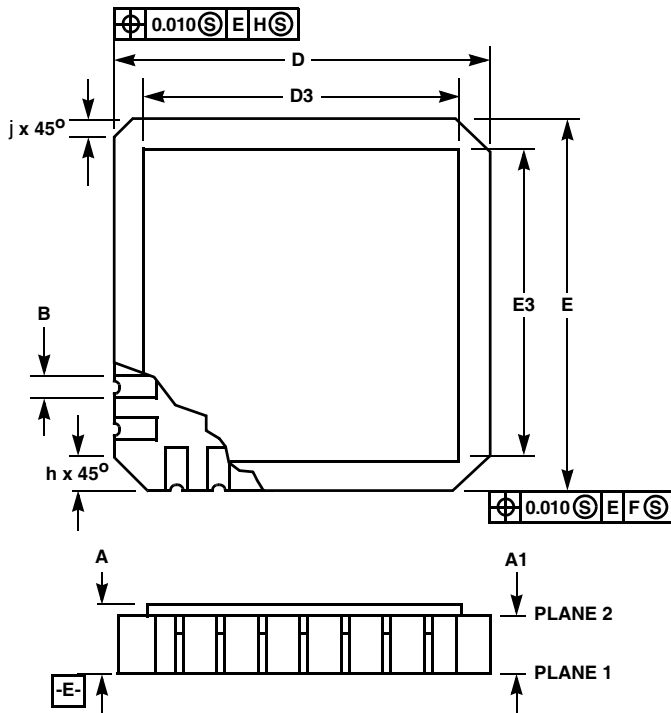

J28.A MIL-STD-1835 CQCC1-N28 (C-4)
28 PAD CERAMIC LEADLESS CHIP CARRIER PACKAGE

| SYMBOL | INCHES | | MILLIMETERS | | NOTES |
|--------|-----------|-------|-------------|-------|-------|
| | MIN | MAX | MIN | MAX | |
| A | 0.060 | 0.100 | 1.52 | 2.54 | 6, 7 |
| A1 | 0.050 | 0.088 | 1.27 | 2.23 | - |
| B | - | - | - | - | - |
| B1 | 0.022 | 0.028 | 0.56 | 0.71 | 2, 4 |
| B2 | 0.072 REF | | 1.83 REF | | - |
| B3 | 0.006 | 0.022 | 0.15 | 0.56 | - |
| D | 0.442 | 0.460 | 11.23 | 11.68 | - |
| D1 | 0.300 BSC | | 7.62 BSC | | - |
| D2 | 0.150 BSC | | 3.81 BSC | | - |
| D3 | - | 0.460 | - | 11.68 | 2 |
| E | 0.442 | 0.460 | 11.23 | 11.68 | - |
| E1 | 0.300 BSC | | 7.62 BSC | | - |
| E2 | 0.150 BSC | | 3.81 BSC | | - |
| E3 | - | 0.460 | - | 11.68 | 2 |
| e | 0.050 BSC | | 1.27 BSC | | - |
| e1 | 0.015 | - | 0.38 | - | 2 |
| h | 0.040 REF | | 1.02 REF | | 5 |
| j | 0.020 REF | | 0.51 REF | | 5 |
| L | 0.045 | 0.055 | 1.14 | 1.40 | - |
| L1 | 0.045 | 0.055 | 1.14 | 1.40 | - |
| L2 | 0.075 | 0.095 | 1.90 | 2.41 | - |
| L3 | 0.003 | 0.015 | 0.08 | 0.038 | - |
| ND | 7 | | 7 | | 3 |
| NE | 7 | | 7 | | 3 |
| N | 28 | | 28 | | 3 |

Rev. 0 5/18/94

NOTES:

1. Metallized castellations shall be connected to plane 1 terminals and extend toward plane 2 across at least two layers of ceramic or completely across all of the ceramic layers to make electrical connection with the optional plane 2 terminals.
2. Unless otherwise specified, a minimum clearance of 0.015 inch (0.38mm) shall be maintained between all metallized features (e.g., lid, castellations, terminals, thermal pads, etc.)
3. Symbol "N" is the maximum number of terminals. Symbols "ND" and "NE" are the number of terminals along the sides of length "D" and "E", respectively.
4. The required plane 1 terminals and optional plane 2 terminals (if used) shall be electrically connected.
5. The corner shape (square, notch, radius, etc.) may vary at the manufacturer's option, from that shown on the drawing.
6. Chip carriers shall be constructed of a minimum of two ceramic layers.
7. Dimension "A" controls the overall package thickness. The maximum "A" dimension is package height before being solder dipped.
8. Dimensioning and tolerancing per ANSI Y14.5M-1982.
9. Controlling dimension: INCH.

Ceramic Dual-In-Line Metal Seal Packages (SBDIP)

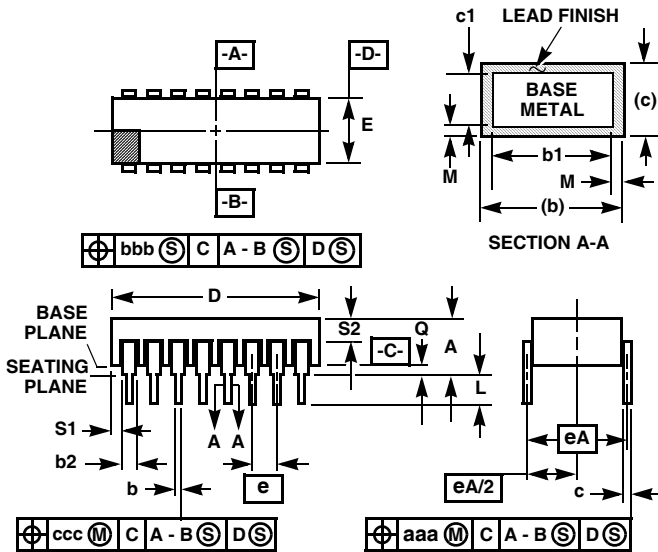

**D16.3 MIL-STD-1835 CDIP2-T16 (D-2, CONFIGURATION C)
16 LEAD CERAMIC DUAL-IN-LINE METAL SEAL PACKAGE**

| SYMBOL | INCHES | | MILLIMETERS | | NOTES |
|----------|-----------|--------|-------------|-------|-------|
| | MIN | MAX | MIN | MAX | |
| A | - | 0.200 | - | 5.08 | - |
| b | 0.014 | 0.026 | 0.36 | 0.66 | 2 |
| b1 | 0.014 | 0.023 | 0.36 | 0.58 | 3 |
| b2 | 0.045 | 0.065 | 1.14 | 1.65 | - |
| b3 | 0.023 | 0.045 | 0.58 | 1.14 | 4 |
| c | 0.008 | 0.018 | 0.20 | 0.46 | 2 |
| c1 | 0.008 | 0.015 | 0.20 | 0.38 | 3 |
| D | - | 0.840 | - | 21.34 | - |
| E | 0.220 | 0.310 | 5.59 | 7.87 | - |
| e | 0.100 BSC | | 2.54 BSC | | - |
| eA | 0.300 BSC | | 7.62 BSC | | - |
| eA/2 | 0.150 BSC | | 3.81 BSC | | - |
| L | 0.125 | 0.200 | 3.18 | 5.08 | - |
| Q | 0.015 | 0.060 | 0.38 | 1.52 | 5 |
| S1 | 0.005 | - | 0.13 | - | 6 |
| S2 | 0.005 | - | 0.13 | - | 7 |
| α | 90° | 105° | 90° | 105° | - |
| aaa | - | 0.015 | - | 0.38 | - |
| bbb | - | 0.030 | - | 0.76 | - |
| ccc | - | 0.010 | - | 0.25 | - |
| M | - | 0.0015 | - | 0.038 | 2 |
| N | 16 | | 16 | | 8 |

NOTES:

1. Index area: A notch or a pin one identification mark shall be located adjacent to pin one and shall be located within the shaded area shown. The manufacturer's identification shall not be used as a pin one identification mark.
2. The maximum limits of lead dimensions b and c or M shall be measured at the centroid of the finished lead surfaces, when solder dip or tin plate lead finish is applied.
3. Dimensions b1 and c1 apply to lead base metal only. Dimension M applies to lead plating and finish thickness.
4. Corner leads (1, N, N/2, and N/2+1) may be configured with a partial lead paddle. For this configuration dimension b3 replaces dimension b2.
5. Dimension Q shall be measured from the seating plane to the base plane.
6. Measure dimension S1 at all four corners.
7. Measure dimension S2 from the top of the ceramic body to the nearest metallization or lead.
8. N is the maximum number of terminal positions.
9. Braze fillets shall be concave.
10. Dimensioning and tolerancing per ANSI Y14.5M - 1982.
11. Controlling dimension: INCH.

Rev. 0 4/94

All Intersil U.S. products are manufactured, assembled and tested utilizing ISO9000 quality systems. Intersil Corporation's quality certifications can be viewed at www.intersil.com/design/quality

Intersil products are sold by description only. Intersil Corporation reserves the right to make changes in circuit design, software and/or specifications at any time without notice. Accordingly, the reader is cautioned to verify that data sheets are current before placing orders. Information furnished by Intersil is believed to be accurate and reliable. However, no responsibility is assumed by Intersil or its subsidiaries for its use; nor for any infringements of patents or other rights of third parties which may result from its use. No license is granted by implication or otherwise under any patent or patent rights of Intersil or its subsidiaries.

For information regarding Intersil Corporation and its products, see www.intersil.com