

Low Profile 500mA LDO with Enable and Power Good/Reset

General Description

The RT9186 is a low-dropout linear regulator providing up to 500mA load current with 160mV dropout. It is especially designed for the application of portable and smart handheld device.

The RT9186 operates from 2.5V to 5.5V supply. The internal P-MOSFET pass transistor allows the regulator to work with 190µA low quiescent current. Its preset output voltage version covers the most frequently used values, including 1.8V/2.5V/3.3V. Output voltage can also be adjusted via the ADJ pin for those other than the preset values.

With only 0.1µA required in the shut down mode, one enable pin is able to control output on/off. RT9186A contains PGOOD function. On the other hand, RT9186B contains \overline{RST} function with 6ms (typ.) time delay.

Ordering Information

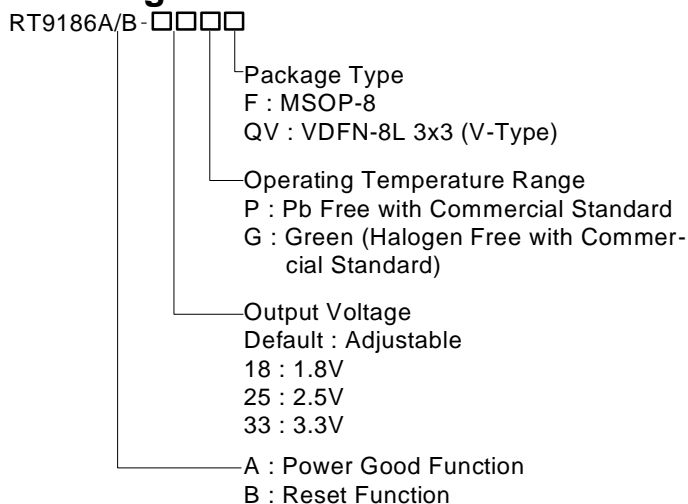

Note :

Richtek Pb-free and Green products are :

- }RoHS compliant and compatible with the current requirements of IPC/JEDEC J-STD-020.
- }Suitable for use in SnPb or Pb-free soldering processes.
- }100%matte tin (Sn) plating.

Features

- | 2.5V to 5.5V Wide Input Range
- | Guaranteed 500mA Output Current
- | Low 160mV Dropout at 500mA
- | 1.8V/2.5V/3.3V Preset Output Voltage Version with Adjustable Range from 0.8V to 4.5V.
- | Reset Output with 6ms (typ.) Delay Time
- | Power Good Output
- | Low 190mA Ground Pin Current
- | 0.1mA Shutdown Current
- | Thermal and Over Current Protection
- | RoHS Compliant and 100% Lead (Pb)-Free

Applications

- | Notebook Computer
- | PDAs/SHDs
- | PCMCIA/Cardbus Card Product
- | Mobile Phone

Marking Information

For marking information, contact our sales representative directly or through a Richtek distributor located in your area, otherwise visit our website for detail.

Pin Configurations

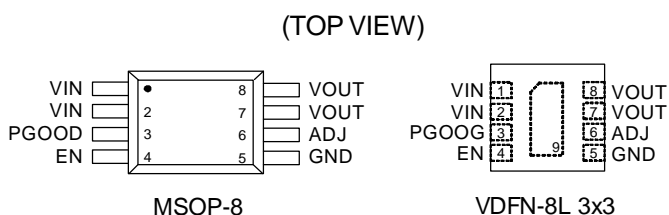

RT9186A

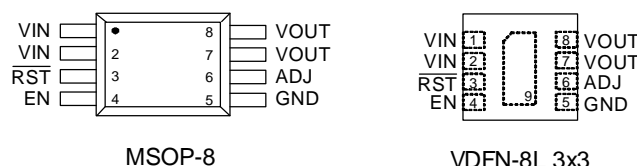

RT9186B

Pin Description

Pin Name	Pin Function
VIN	Power Input Voltage.
VOUT	Output Voltage.
GND	Ground.
EN	Chip Enable (Active-High). There should be a pull low resistor 100kΩ connected to GND when the control signal is floating.
PGOOD	Power Good Indicator. (RT9186A).
$\overline{\text{RST}}$	Open-Drain Active-Low Reset Output. Connect a 100kΩ to VOUT to obtain output voltage. In shutdown the $\overline{\text{RST}}$ output is low. (RT9186B).
ADJ	Output Voltage Setting. Connect to GND for Fixed output voltage model.

Typical Application Circuit

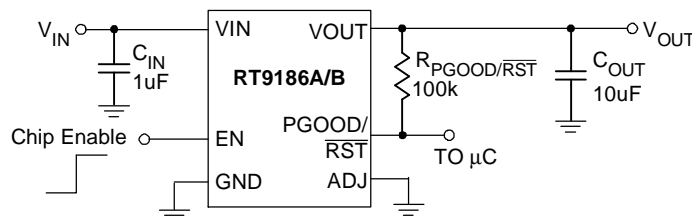

Figure 1. Fixed Voltage Regulator

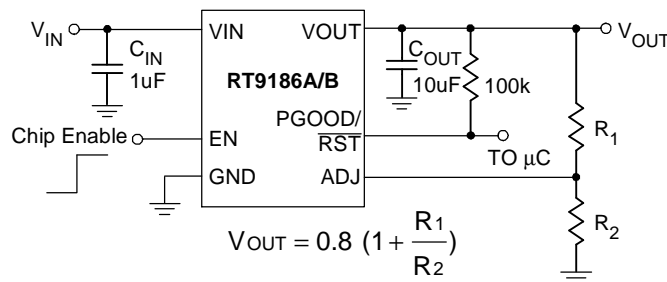
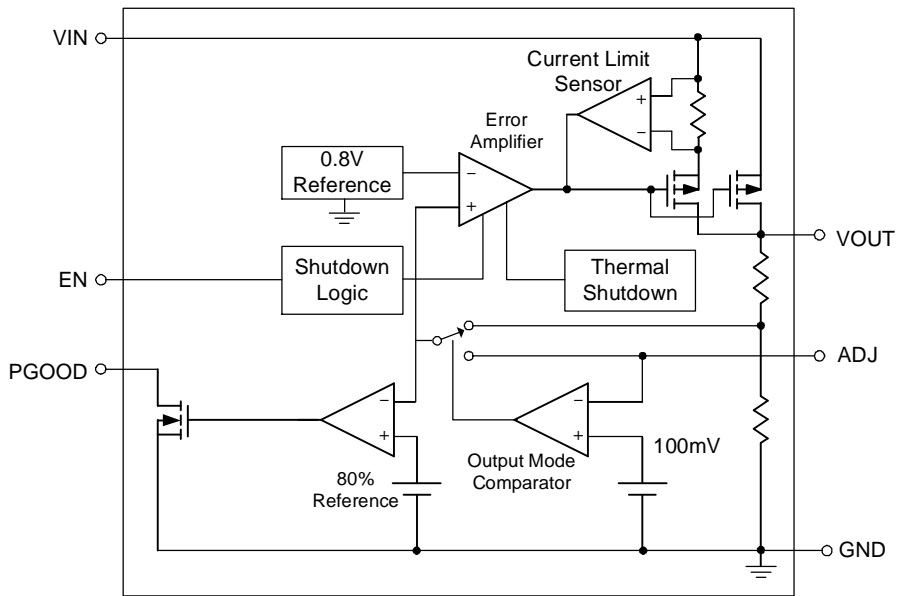

Figure 2. Adjustable Voltage Regulator

Note1 : R2 should be less than 80k to ensure regulation.

Note2 : X5R or X7R input capacitor $\geq 1\text{mF}$ is recommended for output stability.

Function Block Diagram



-RT9186A-

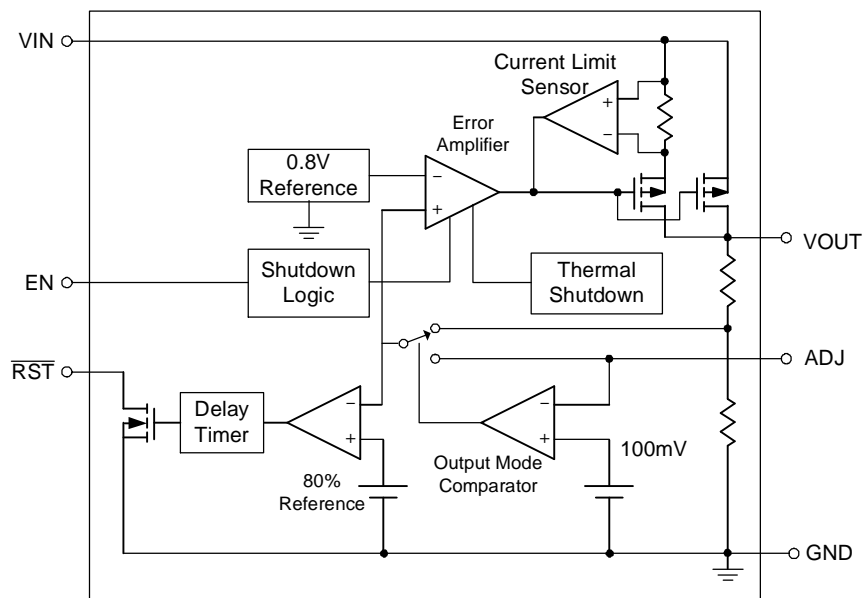

-RT9186B-

Timing Diagram

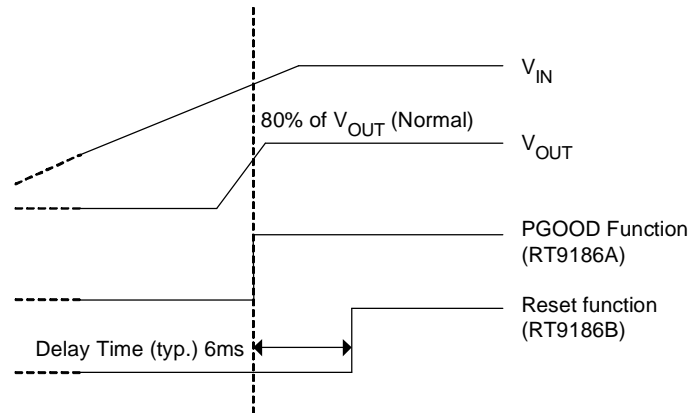

Absolute Maximum Ratings (Note 1)

Input Voltage	-----	7V
Storage Temperature Range	-----	-65°C to 150°C
Lead Temperature (Soldering, 10 sec.)	-----	260°C
Power Dissipation, PD @ $T_A = 25^\circ\text{C}$		
MSOP-8	-----	0.625W
VDFN-8L 3x3	-----	0.952W
Package Thermal Resistance (Note 4)		
MSOP-8, θ_{JA}	-----	160°C/W
VDFN-8L 3x3, θ_{JA}	-----	105°C/W
Junction Temperature	-----	150°C
ESD Susceptibility (Note 2)		
HBM (Human Body Mode)	-----	2kV
MM (Machine Mode)	-----	200V

Recommended Operating Conditions (Note 3)

Input Voltage	-----	2.5V to 5.5V
Junction Temperature Range	-----	-40°C to 125°C
Ambient Temperature Range	-----	-40°C to 85°C

Electrical Characteristics

($V_{IN} = V_{OUT(NOM)} + 500mV$ or $V_{IN} = +2.5V$ (whichever is greater), $T_A = 25^{\circ}C$, unless otherwise specified)

Parameter	Symbol	Test Conditions	Min	Typ	Max	Units	
General Specification							
Input Under Voltage Lock-Out	V_{UVLO}		2.0	2.3	2.4	V	
Output Voltage Accuracy (Preset Mode)	ΔV_{OUT}	$I_{OUT} = 1mA$ to $500mA$	-3	0	+3	%	
Adjustable Output Voltage Range	V_{OUT_ADJ}		0.8	--	4.5	V	
ADJ Pin Voltage	V_{ADJ}		0.784	0.8	0.816	V	
ADJ Input Bias Current	I_{ADJ}	$V_{ADJ} = +0.8V$	--	10	100	nA	
Short Circuit Current Limit	I_{LIM}	$V_{OUT} = 0V$	0.9	1.4	2.0	A	
Quiescent Current (Note 6)	I_Q	$I_{OUT} = 0mA$	--	190	250	μA	
Dropout Voltage (Note 5)	V_{DROP}	$I_{OUT} = 500mA$	$V_{OUT} = 2.5V$	--	200	330	mV
			$V_{OUT} = 3.3V$	--	160	220	
Line Regulation	ΔV_{LINE}	$V_{OUT} + 0.1V < V_{IN} < 5.5V$ $I_{OUT} = 5mA$	--	0.02	0.125	%/V	
Load Regulation (Note 7)	ΔV_{LOAD}	$I_{OUT} = 1mA$ to $500mA$	--	21	40	mV	
Chip Enable							
Standby Current	I_{STBY}	$V_{IN} = 5.5V$	--	0.1	2	μA	
EN Threshold	Logic-Low Voltage	V_{ENL}	$V_{IN} = 2.5V$	--	--	0.7	V
	Logic-High Voltage	V_{ENH}	$V_{IN} = 5.5V$	1.6	--	--	
EN Input Bias Current	I_{EN}	$V_{CE} = 5.5V$	--	20	100	nA	
Reset							
Reset Output Low Voltage	V_{OL}	Reset Output Sinking 2mA	--	50	100	mV	
Output High Leakage Current		$V_{RST} = 5V$	--	--	100	nA	
Threshold to Output Voltage		Rising edge, referred to V_{OUT}	77	80	83	%	
Reset Delay Time	T_{DELAY}	Rising edge of V_{OUT} to V_{RST}	0.7	6	8	ms	
Power Good							
PGOOD Output Low Voltage		PGOOD Output sinking 2mA	--	50	100	mV	
Output High Leakage Current		$V_{PGOOD} = 5V$	--	--	100	nA	
Threshold to Output Voltage		Rising edge, referred to V_{OUT}	77	80	83	%	
Thermal Protection							
Thermal Shutdown Temperature	T_{SD}		--	160	--	$^{\circ}C$	
Thermal Shutdown Hysteresis	ΔT_{SD}		--	30	--	$^{\circ}C$	

- Note 1.** Stresses listed as the above "Absolute Maximum Ratings" may cause permanent damage to the device. These are for stress ratings. Functional operation of the device at these or any other conditions beyond those indicated in the operational sections of the specifications is not implied. Exposure to absolute maximum rating conditions for extended periods may remain possibility to affect device reliability.
- Note 2.** Devices are ESD sensitive. Handling precaution is highly recommended.
- Note 3.** The operating conditions beyond the recommended range is not guaranteed.
- Note 4.** θ_{JA} is measured in the natural convection at $T_A = 25^\circ\text{C}$ on a low effective thermal conductivity test board (single-layer, 1S) of JEDEC 51-3 thermal measurement standard.
- Note 5.** The dropout voltage is defined as $V_{IN} - V_{OUT}$, which is measured when V_{OUT} is $V_{OUT(NORMAL)} - 100\text{mV}$.
- Note 6.** Quiescent, or ground current, is the difference between input and output currents. It is defined by $I_Q = I_{IN} - I_{OUT}$ under no load condition ($I_{OUT} = 0\text{mA}$). The total current drawn from the supply is the sum of the load current plus the ground pin current.
- Note 7.** Regulation is measured at constant junction temperature by using a 20ms current pulse. Devices are tested for load regulation in the load range from 1mA to 300mA and 500mA respectively.

Typical Operating Characteristics

$C_{IN} = 1\mu F$ (X7R Ceramic), $C_{OUT} = 10\mu F$ (Y5V Ceramic), $T_A = 25^\circ C$, unless otherwise specified.

Output Voltage vs. Input Voltage

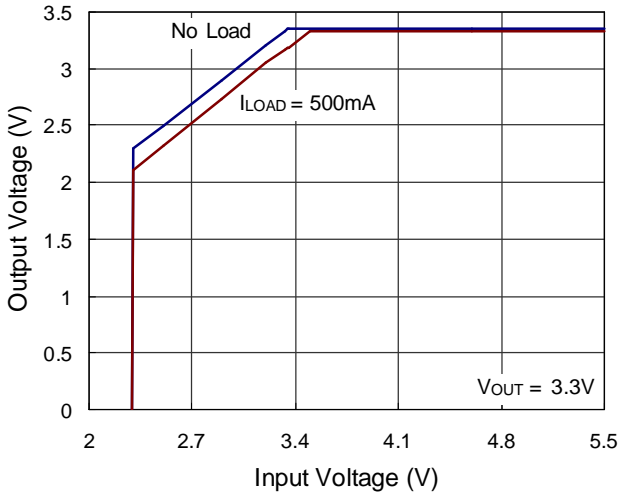

Output Voltage vs. Temperature

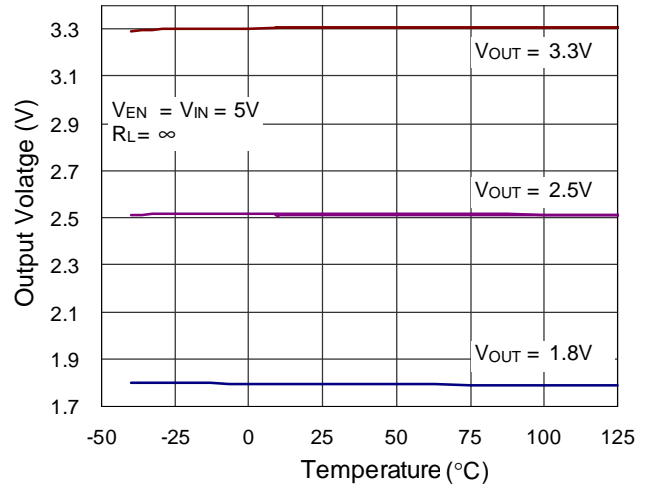

Quiescent Current vs. Temperature

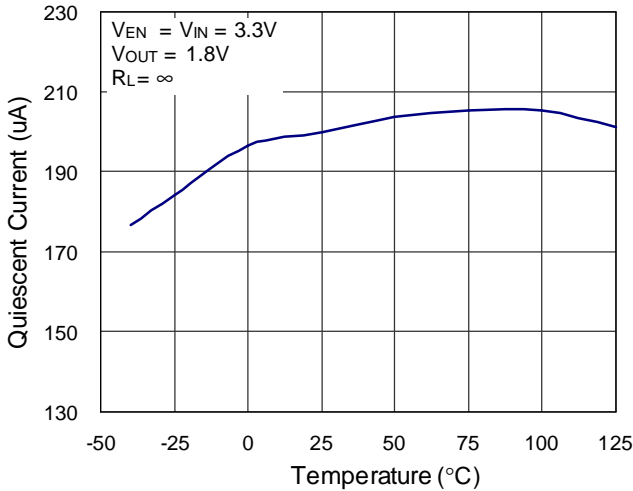

Dropout Voltage vs. Load Current

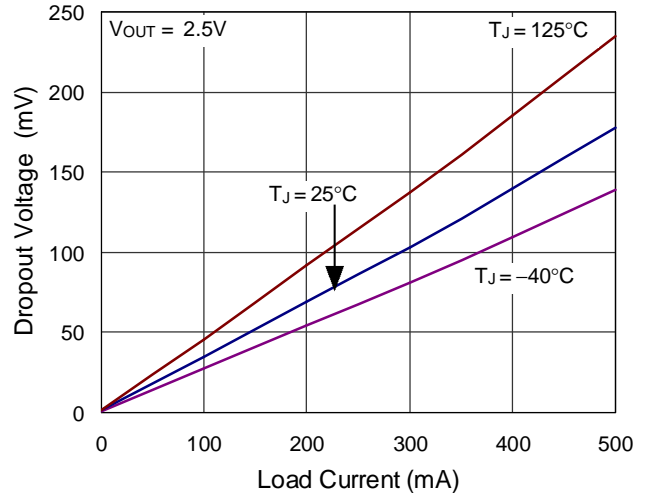

Short Circuit Current Limit

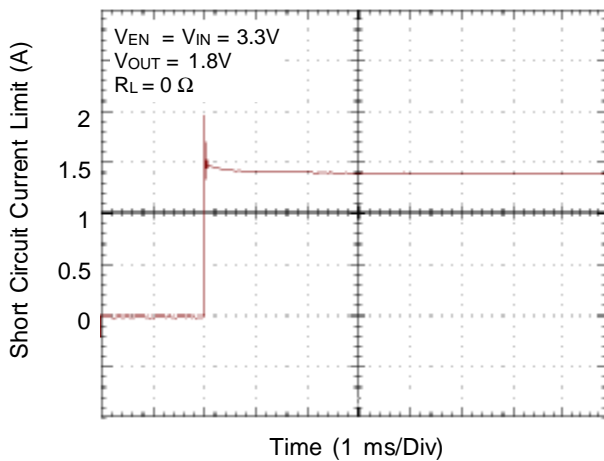

Short Circuit Current Limit vs. Temperature

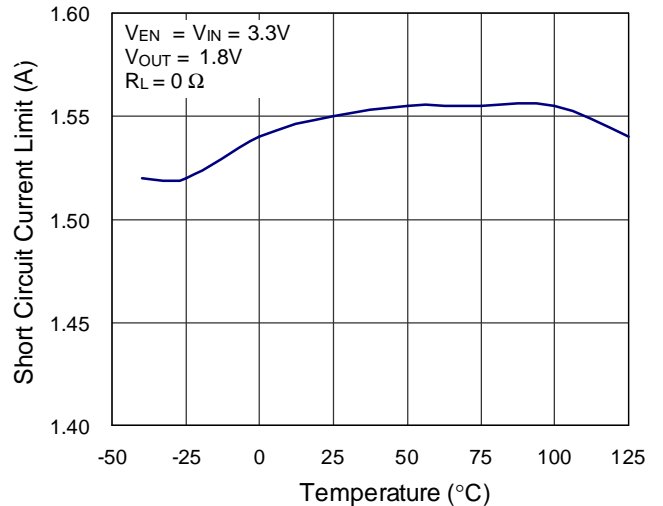

Line Transient Response

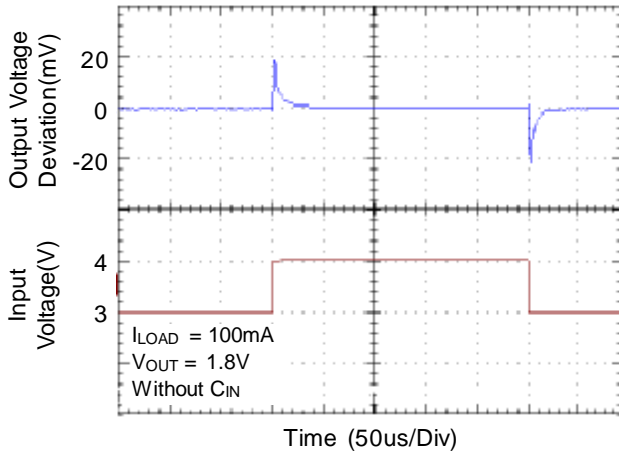

Load Transient Response

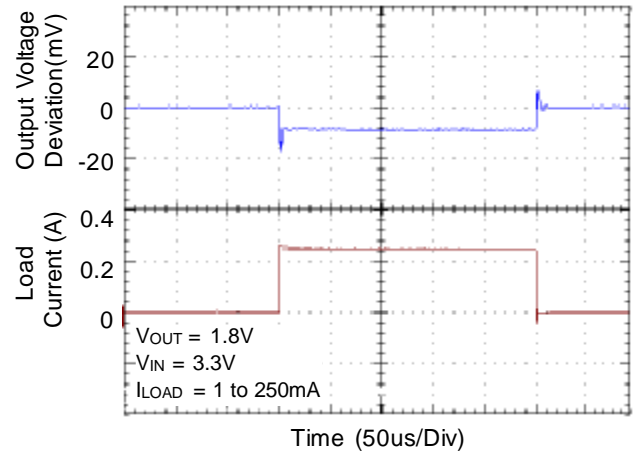

Reset Response

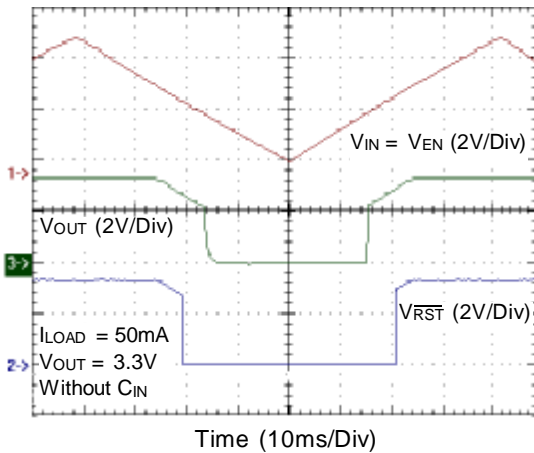

Reset Response

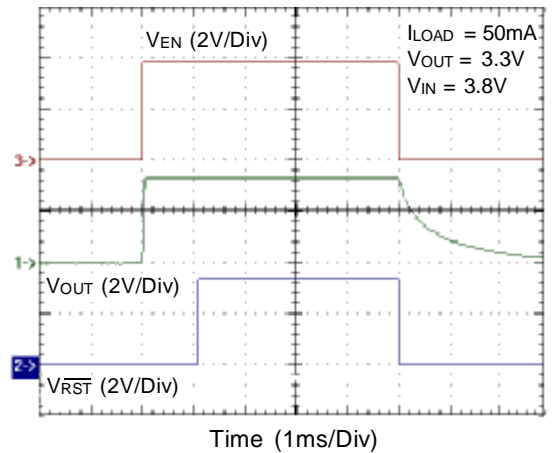

PGOOD Response

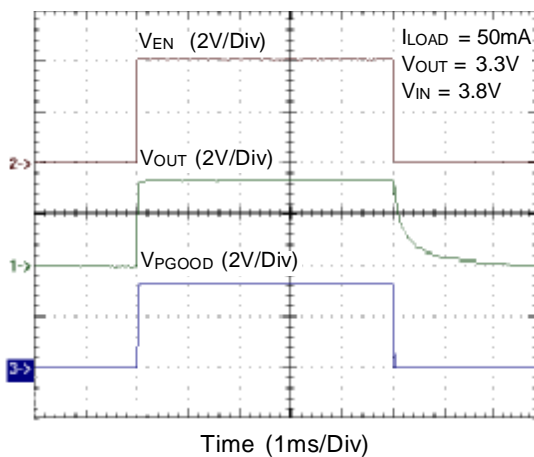

Shutdown Response

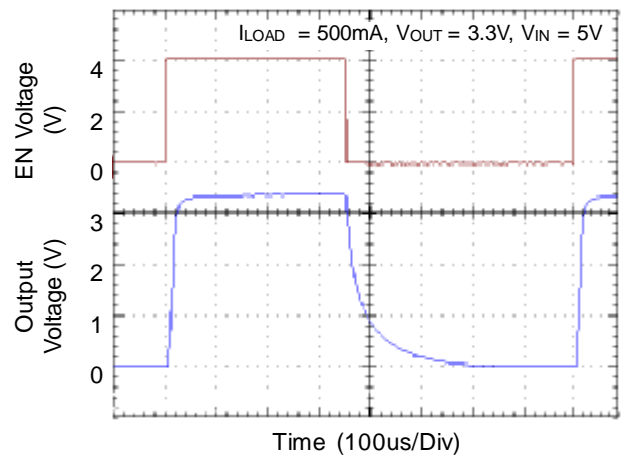

Application Information

Capacitor Selection and Regulator Stability

Careful selection of the external capacitors for RT9186 is highly recommended in order to remain high stability and performance.

Regarding the Input capacitor, connecting an X7R or X5R ceramic capacitor which is $\geq 1\mu\text{F}$ between input and ground is a must. Distance less than 1 cm between input pin and ground of RT9186 is recommended to avoid any instability. With larger value of capacitor adding on lower ESR could result in better performance for both PSRR and line transient response.

Regarding the output capacitor, connecting a $10\mu\text{F}$ capacitor between output and ground is a must. Any capacitor is acceptable only with a highlight of relation between ESR region and Load current, shown in below. Output capacitor with larger capacitance can reduce noise and improve load transient response, stability, and PSRR. The same as Input capacitor, distance less than 1 cm between output pin and ground of RT9186 is recommended to avoid any instability.

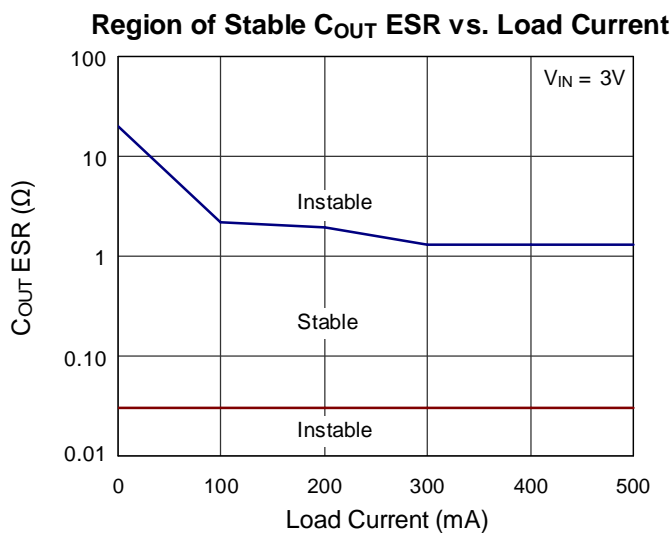

Input-Output (Dropout) Voltage

A regulator's minimum input-to-output voltage differential (dropout voltage) determines the lowest usable supply voltage. In battery-powered systems, this determines the useful end-of-life battery voltage. Because the device uses a P-MOSFET, its dropout voltage is a function of drain-to-source on-resistance, $R_{\text{DS(ON)}}$, multiplied by the load current:

$$V_{\text{DROPOUT}} = V_{\text{IN}} - V_{\text{OUT}} = R_{\text{DS(ON)}} I_{\text{OUT}}$$

Over-Current and Short-Circuit Protection

The RT9186 continuously monitors output current to provide maximum safety. In the event of output over current or short-circuit, over-current protection function will activate and override the voltage regulation function to limit output current at 1.4A typically. Large power dissipation at this condition may cause chip temperature to raise and trigger the over temperature protection if over-current or short-circuit is not removed in a short time

Power Good and Reset

The power good and the reset output is an open-drain output. Connect an $100\text{k}\Omega$ pull up resistor to V_{OUT} to obtain an output voltage. The power good will output high immediately after the output voltage arrives 80% of normal output voltage. In the same situation, the reset will output high with 6ms delay time. See Timing Diagram and Typical Operating Characteristics.

Adjustable Operation

The output voltage of RT9186 is adjustable from 0.8V to 4.5V by an external voltage divider as shown in Typical Application Circuit Figure 2. The value of R2 should be less than $80\text{k}\Omega$ to ensure regulation.

Chip Enable Operation

Pull the EN pin low to drive the device into shutdown mode. At the same time, pin 3 ($\overline{\text{PGOOD}}/\overline{\text{RST}}$) is pulled low. During shutdown mode, the standby current drops to $0.1\mu\text{A}$ (typ). The output voltage decay rate is determined by the external capacitor and load current. Drive the EN pin high to turn on the device again.

Reverse Current Path

The P-MOSFET pass element of RT9186 has an inherent diode connected between the regulator input and output as shown in Figure 3. The inherent diode will be forward biased and conduct an unlimited current if V_{OUT} is sufficiently higher than V_{IN} , a Schottky diode is recommended connecting parallel with the inherent diode in the application where output voltage may be higher than input voltage as shown in Figure 4. This Schottky will clamp the forward bias voltage to 0.3V and conduct the possible current to protect the RT9186 from damage by unlimited current.

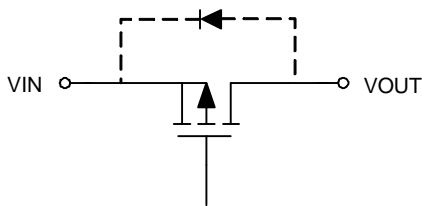

Figure 3. Inherent Diode of P-MOSFET Pass Transistor

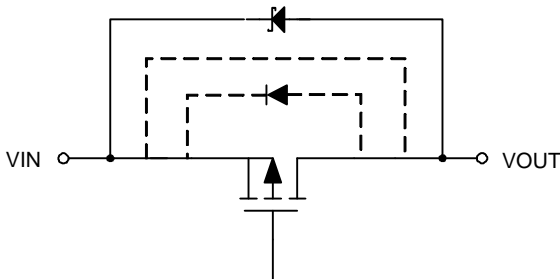

Figure 4. Schottky Diode Parallel with The Inherent Diode

Thermal Considerations

Thermal protection limits power dissipation in RT9186A/B. When the operation junction temperature exceeds 160°C, the OTP circuit starts the thermal shutdown function and turns the pass element off. The pass element turn on again after the junction temperature cools by 30°C.

For continuous operation, do not exceed absolute maximum operation junction temperature 125°C. The power dissipation definition in device is :

$$P_D = (V_{IN} - V_{OUT}) \times I_{OUT} + V_{IN} \times I_Q$$

The maximum power dissipation depends on the thermal resistance of IC package, PCB layout, the rate of

surroundings airflow and temperature difference between junction to ambient. The maximum power dissipation can be calculated by following formula :

$$P_{D(MAX)} = (T_{J(MAX)} - T_A) / \theta_{JA}$$

Where $T_{J(MAX)}$ is the maximum operation junction temperature 125°C, T_A is the ambient temperature and the θ_{JA} is the junction to ambient thermal resistance.

For recommended operating conditions specification of RT9186A/B, where $T_{J(MAX)}$ is the maximum junction temperature of the die (125°C) and T_A is the maximum ambient temperature. The junction to ambient thermal resistance θ_{JA} is layout dependent. For VDFN-8L 3x3 package, the thermal resistance θ_{JA} is 105°C/W on the standard JEDEC 51-3 single-layer 1S thermal test board and 70°C/W on the standard JEDEC 51-7 4-layers 2S2P thermal test board. The maximum power dissipation at $T_A = 25^\circ\text{C}$ can be calculated by following formula :

$$P_{D(MAX)} = (125^\circ\text{C} - 25^\circ\text{C}) / 105 = 0.952\text{W for single-layer 1S board}$$

$$P_{D(MAX)} = (125^\circ\text{C} - 25^\circ\text{C}) / 70 = 1.428\text{W for 4-layers 2S2P board}$$

The maximum power dissipation depends on operating ambient temperature for fixed $T_{J(MAX)}$ and thermal resistance θ_{JA} . For RT9186A/B packages, the Figure 5 of derating curves allows the designer to see the effect of rising ambient temperature on the maximum power allowed.

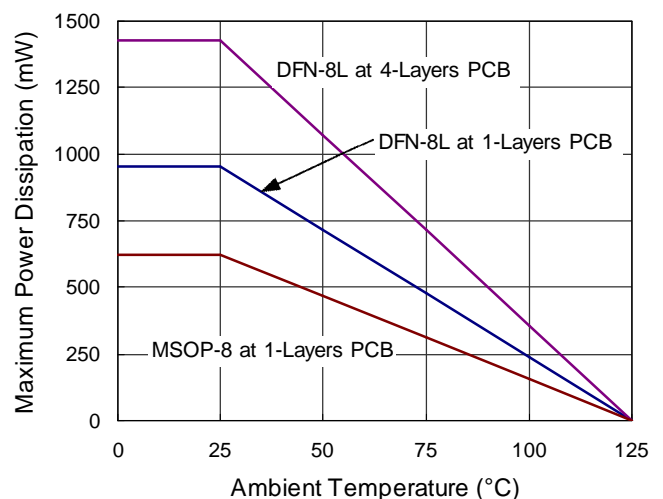

Figure 5

PCB Layout

Good board layout practices must be used or instability can be induced because of ground loops and voltage drops. The input and output capacitors **MUST** be directly connected to the input, output, and ground pins of the device using traces which have no other currents flowing through them.

The best way to do this is to layout C_{IN} and C_{OUT} near the device with short traces to the V_{IN} , V_{OUT} , and ground pins. The regulator ground pin should be connected to the external circuit ground so that the regulator and its capacitors have a "single point ground".

It should be noted that stability problems have been seen in applications where "vias" to an internal ground plane were used at the ground points of the device and the input and output capacitors. This was caused by varying ground potentials at these nodes resulting from current flowing through the ground plane. Using a single point ground technique for the regulator and its capacitors fixed the problem. Since high current flows through the traces going into V_{IN} and coming from V_{OUT} , Kelvin connect the capacitor leads to these pins so there is no voltage drop in series with the input and output capacitors.

Optimum performance can only be achieved when the device is mounted on a PC board according to the MSOP-8 Board Layout diagram.

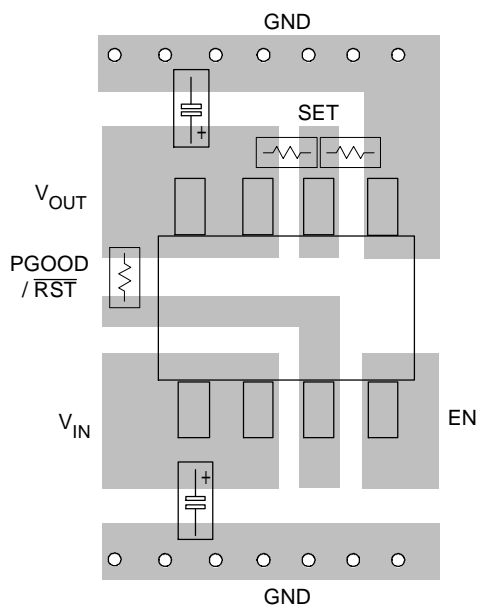

MSOP-8 Board Layout

Outline Dimension

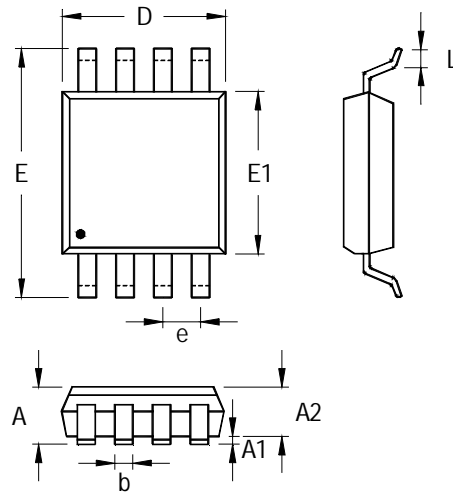

Symbol	Dimensions In Millimeters		Dimensions In Inches	
	Min	Max	Min	Max
A	0.810	1.100	0.032	0.043
A1	0.000	0.150	0.000	0.006
A2	0.750	0.950	0.030	0.037
b	0.220	0.380	0.009	0.015
D	2.900	3.100	0.114	0.122
e	0.650		0.026	
E	4.800	5.000	0.189	0.197
E1	2.900	3.100	0.114	0.122
L	0.400	0.800	0.016	0.031

8-Lead MSOP Plastic Package

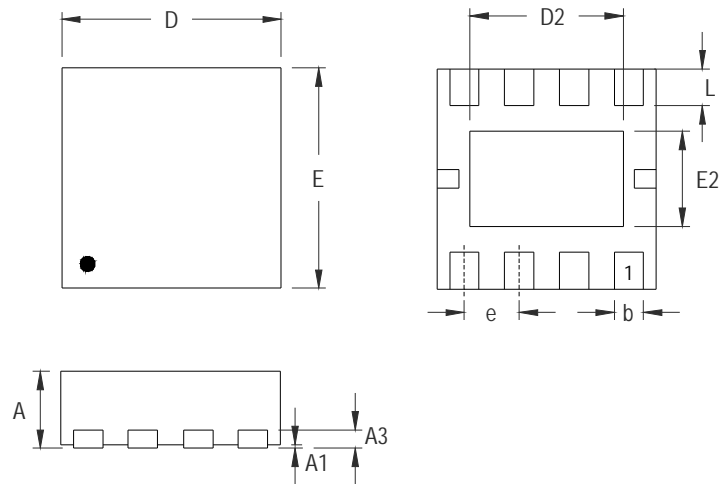

Symbol	Dimensions In Millimeters		Dimensions In Inches	
	Min	Max	Min	Max
A	0.800	1.000	0.031	0.039
A1	0.000	0.050	0.000	0.002
A3	0.175	0.228	0.007	0.009
b	0.200	0.300	0.008	0.012
D	2.950	3.050	0.116	0.120
D2	2.250	2.350	0.089	0.093
E	2.950	3.050	0.116	0.120
E2	1.450	1.550	0.057	0.061
e	0.650		0.026	
L	0.425	0.525	0.017	0.021

V-Type 8L DFN 3x3 Package

Richtek Technology Corporation

Headquarter
 5F, No. 20, Taiyuen Street, Chupei City
 Hsinchu, Taiwan, R.O.C.
 Tel: (8863)5526789 Fax: (8863)5526611

Richtek Technology Corporation

Taipei Office (Marketing)
 8F, No. 137, Lane 235, Paochiao Road, Hsintien City
 Taipei County, Taiwan, R.O.C.
 Tel: (8862)89191466 Fax: (8862)89191465
 Email: marketing@richtek.com