

SPS-9340WG / SPS-9340BWG (RoHS Compliant)

3.3V / 1550 nm / 2.5 Gbps Digital Diagnostic SFP LC SINGLE-MODE TRANSCEIVER

FEATURES

- | Hot-Pluggable SFP Footprint LC Optical Transceiver
- | Small Form-Factor Pluggable (SFP) MSA compatible
- | Compliant with SONET OC-48 (IR-2) / SDH STM-16 (S-16.2)
- | Compliant with Fibre Channel 1x/2x SM-LC-L FC-PI
- | Compliant with IEEE 802.3z 1000BASE
- | **SFF-8472 Digital Diagnostic Function**
- | 1550 nm DFB LD Transmitter
- | 18 dB Power Budget at Least
- | Distance up to 40km
- | AC/AC Coupling according to MSA
- | Single +3.3 V Power Supply
- | RoHS Compliant
- | 0 to 70°C Operation : SPS-9340WG
- | -10 to 85°C Operation : SPS-9340BWG
- | Class 1 Laser International Safety Standard IEC-60825 Compliant

DESCRIPTION

The SPS-9340WG series single mode transceivers is small form factor pluggable module for bi-directional serial optical data communications such as SONET OC-48 / SDH STM-16, Gigabit Ethernet 1000BASE and Fibre Channel 1x/2x SM-LC-L FC-PI. It is with the SFP 20-pin connector to allow hot plug capability. Digital diagnostic functions are available via an I²C. This module is designed for single mode fiber and operates at a nominal wavelength of 1550 nm. A guaranteed minimum optical link budget of 18 dB is offered which can correspond to a link distance of over 40 km (assuming worst case fiber loss of 0.3 dB/km). The transmitter section uses a multiple quantum well 1550 nm DFB laser and is a class 1 laser compliant according to International Safety Standard IEC-60825. The receiver section uses an integrated InGaAs detector preamplifier (IDP) mounted in an optical header and a limiting post-amplifier IC.

APPLICATIONS

- | ATM Switches and Routers
- | SONET / SDH Switch Infrastructure
- | XDSL Applications
- | Metro Edge Switching

LASER SAFETY

This single mode transceiver is a Class 1 laser product. It complies with IEC-60825 and FDA 21 CFR 1040.10 and 1040.11. The transceiver must be operated within the specified temperature and voltage limits. The optical ports of the module shall be terminated with an optical connector or with a dust plug.

ORDER INFORMATION

| P/No. | Bit Rate (Gb/s) | SONET /SDH | Distance (km) | Wavelength (nm) | Package | Temp. (°C) | TX Power (dBm) | RX Sens. (dBm) | RoHS Compliant |
|-------------|-----------------|-------------|---------------|-----------------|-----------------|------------|----------------|----------------|----------------|
| SPS-9340WG | 2.488 | IR-2/S-16.2 | 40 | 1550 DFB | LC SFP with DMI | 0 to 70 | 3 to -2 | -20 | Yes |
| SPS-9340BWG | 2.488 | IR-2/S-16.2 | 40 | 1550 DFB | LC SFP with DMI | -10 to 85 | 3 to -2 | -20 | Yes |

Absolute Maximum Ratings

| Parameter | Symbol | Min | Max | Units | Notes |
|----------------------------|--------|----------|----------|-------|---------------------------|
| Storage Temperature | Tstg | -40 | 85 | °C | |
| Operating Case Temperature | Topr | 0 -10 | 70 85 | °C | SPS-9340WG SPS-9340BWG |
| Power Supply Voltage | Vcc | -0.5 | 3.6 | V | |

Recommended Operating Conditions

| Parameter | Symbol | Min | Typ | Max | Units / Notes |
|----------------------------|------------------------|----------|------|----------|-------------------------------------|
| Power Supply Voltage | Vcc | 3.1 | 3.3 | 3.5 | V |
| Operating Case Temperature | Topr | 0 -10 | | 70 85 | °C / SPS-9340WG °C / SPS-9340BWG |
| Power Supply Current | I _{CC(TX+RX)} | | 200 | 300 | mA |
| Data Rate | | 622 | 2488 | 2670 | Mb/s / 1 |

1. OC-48, Gigabit Ethernet and 1x/2x Fibre Channel compliant.

| Transmitter Specifications (0°C < Topr < 70°C, 3.1V < Vcc < 3.5V) | | | | | | |
|---|--|------|------|---------|---------|--------------------|
| Parameter | Symbol | Min | Typ | Max | Units | Notes |
| Optical | | | | | | |
| Optical Transmit Power | Po | -2 | --- | 3 | dBm | 1 |
| Output Center Wavelength | λ | 1480 | 1550 | 1580 | nm | |
| Output Spectrum Width | $\Delta\lambda$ | --- | --- | 1 | nm | -20 dB Width |
| Side Mode Suppression Ratio | SMSR | 30 | | | dB | |
| Extinction Ratio | ER | 8.2 | --- | --- | dB | |
| Output Eye | Compliant with Telecordia GR-253-GORE and ITU-T Recommendation G.957 | | | | | |
| Optical Rise Time | tr | | | 150 | ps | 20 % to 80% Values |
| Optical Fall Time | tf | | | 150 | ps | 20 % to 80% Values |
| Relative Intensity Noise | RIN | | | -120 | dB/Hz | |
| Electrical | | | | | | |
| Data Input Current – Low | IL | -350 | | | μ A | |
| Data Input Current – High | I _H | | | 350 | μ A | |
| Differential Input Voltage | V _{IH} - V _{IL} | 0.5 | | 2.4 | V | Peak-to-Peak |
| TX Disable Input Voltage – Low | T _{DIS, L} | 0 | | 0.5 | V | 2 |
| TX Disable Input Voltage – High | T _{DIS, H} | 2.0 | | Vcc | V | 2 |
| TX Disable Assert Time | T _{ASSERT} | | | 10 | μ s | |
| TX Disable Deassert Time | T _{DEASSERT} | | | 1 | ms | |
| TX Fault Output Voltage -- Low | T _{FaultL} | 0 | | 0.5 | V | 3 |
| TX Fault Output Voltage -- High | T _{FaultH} | 2.0 | | Vcc+0.3 | V | 3 |

1. Output power is power coupled into a 9/125 μ m single mode fiber.
2. There is an internal 4.7K to 10K ohm pull-up resistor to VccTX.
3. Open collector compatible, 4.7K to 10K ohm pull-up to Vcc (Host Supply Voltage).

| Receiver Specifications (0°C < Topr < 70°C, 3.1V < Vcc < 3.5V) | | | | | | |
|--|-----------------------------------|------|-----|---------|-------|-------------------------|
| Parameter | Symbol | Min | Typ | Max | Units | Notes |
| Optical | | | | | | |
| Sensitivity | Sens | | | -20 | dBm | 4,5 |
| Maximum Input Power | Pin | 0 | | | dBm | 4,5 |
| Signal Detect -- Asserted | Pa | --- | | -20 | dBm | Transition: low to high |
| Signal Detect -- Deasserted | Pd | -30 | --- | --- | dBm | Transition: high to low |
| Signal detect -- Hysteresis | | 1.0 | --- | | dB | |
| Wavelength of Operation | | 1100 | --- | 1600 | nm | |
| Electrical | | | | | | |
| Differential Output Voltage | V _{OH} - V _{OL} | 0.6 | | 2.0 | V | |
| Output LOS Voltage -- Low | V _{OL} | 0 | | 0.5 | V | 6 |
| Output LOS Voltage -- High | V _{OH} | 2.0 | | Vcc+0.3 | V | 6 |

4. Measured at 2²³-1 PRBS at BER 1E-10.
5. Measured at 2⁷-1 PRBS at BER 1E-12 for 2.125 Gb/s, 1.25Gb/s, and 1.063 Gb/s.
6. Open collector compatible, 4.7K to 10K ohm pull-up to Vcc (Host Supply Voltage).

CONNECTION DIAGRAM

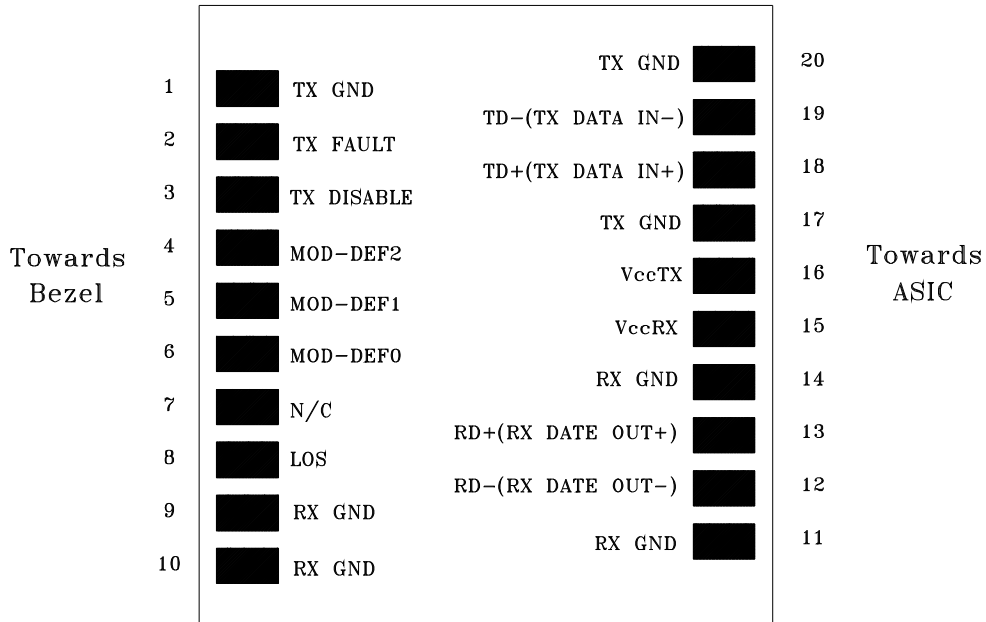

| PIN | Signal Name | Description | PIN | Signal Name | Description |
|-----|-------------|---|-----|--------------|-----------------------------|
| 1 | TX GND | Transmitter Ground | 11 | RX GND | Receiver Ground |
| 2 | TX Fault | Transmitter Fault Indication | 12 | RX DATA OUT- | Inverse Receiver Data Out |
| 3 | TX Disable | Transmitter Disable (Module disables on high or open) | 13 | RX DATA OUT+ | Receiver Data Out |
| 4 | MOD-DFE2 | Modulation Definition 2 – Two wires serial ID Interface | 14 | RX GND | Receiver Ground |
| 5 | MOD-DEF1 | Modulation Definition 1 – Two wires serial ID Interface | 15 | Vcc RX | Receiver Power – 3.3V±5% |
| 6 | MOD-DEF0 | Modulation Definition 0 – Ground in Module | 16 | Vcc TX | Transmitter Power – 3.3V±5% |
| 7 | N/C | Not Connected | 17 | TX GND | Transmitter Ground |
| 8 | LOS | Loss of Signal | 18 | TX DATA IN+ | Transmitter Data In |
| 9 | RX GND | Receiver Ground | 19 | TX DATA IN- | Inverse Transmitter Data In |
| 10 | RX GND | Receiver Ground | 20 | TX GND | Transmitter Ground |

Module Definition

| Module Definition | MOD-DEF2 PIN 4 | MOD-DEF1 PIN 5 | MOD-DEF0 PIN 6 | Interpretation by Host |
|-------------------|-------------------|-------------------|-------------------|-----------------------------------|
| 4 | SDA | SCL | LV-TTL Low | Serial module definition protocol |

Module Definition 4 specifies a serial definition protocol. For this definition, upon power up, MOD-DEF(1:2) appear as no connector (NC) and MOD-DEF(0) is TTL LOW. When the host system detects this condition, it activates the serial protocol. The protocol uses the 2-wire serial CMOS E²PROM protocol of the ATMEL AT24C01A/02/04 family of components.

RECOMMENDED CIRCUIT SCHEMATIC

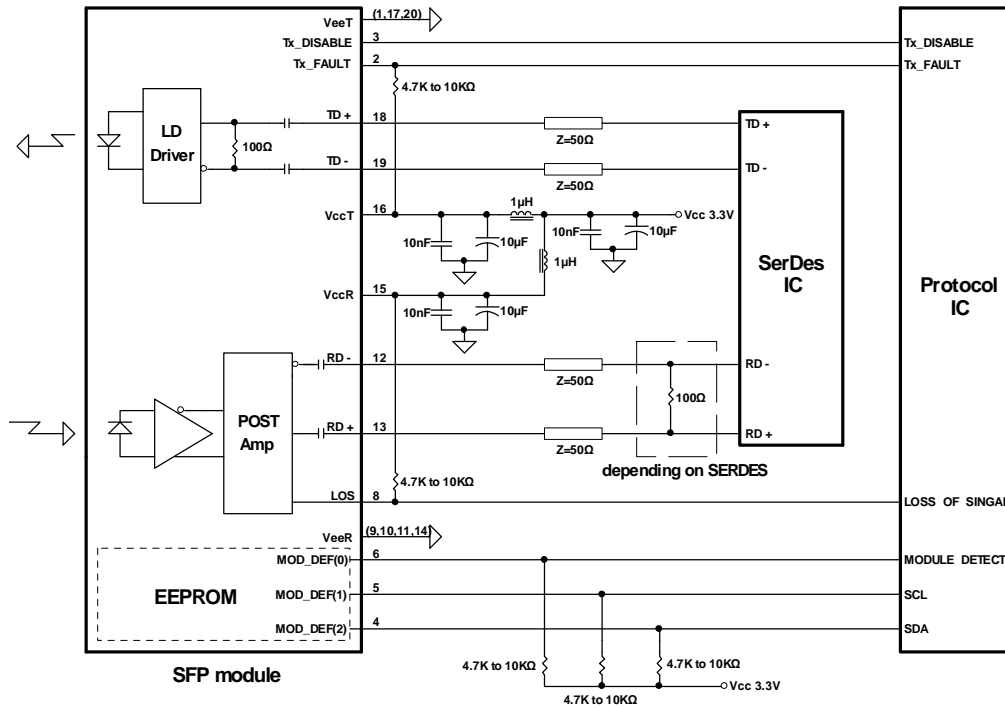

PACKAGE DIAGRAM

Units in mm

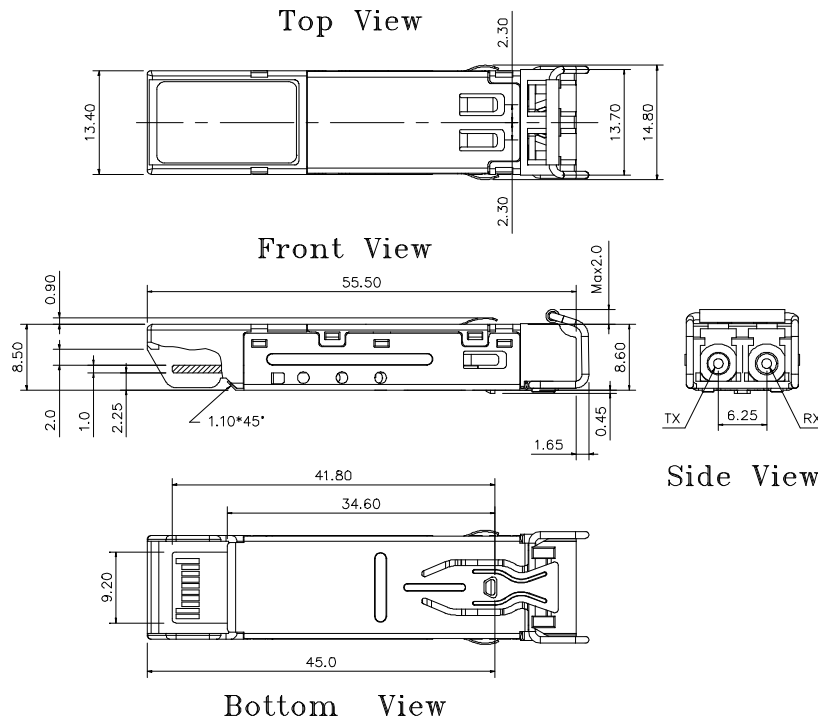

Note: Specifications subject to change without notice.