

NEW

IMAGE SENSOR

Flat panel sensor C9730DK-10

Large area soft X-ray imaging, high resolution

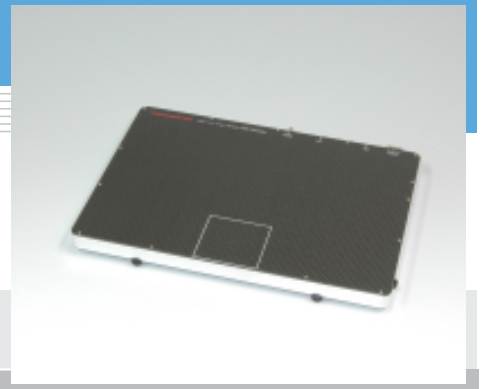

Flat panel sensor C9730DK-10 is two-dimensional CMOS image sensor module designed for X-ray imaging which requires high resolution, large area and wide dynamic range. A target material of X-ray source and X-ray energy adequate for the sensor is Mo and 17 keV. The device shape is thin cassette which incorporate on-chip high-resolution scintillator and a control board. An on-board USB2.0 interface can realize fast data transfer to C9730DK-10.

Features

- High resolution
- 1056 × 1056 pixels (50 μm pitch)
- 14-bit digital output
- High-speed imaging:
4 frame/s (single operation)
- CsI scintillator directly deposited on photosensitive surface
- No dead area (insensitive area) due to seamless structure

Applications

- X-ray imaging (optimized to 17 keV)

■ Block diagram

C9730DK-10 is a lightweight and compact flat panel sensor consisting of a sensor board and a control board. The sensor board also has 8 charge-sensitive amplifier arrays each having 132 channel amplifiers with a horizontal shift register. Analog video signals are amplified as the charge on each video line by 1056 ch charge amplifiers with CDS (Correlated Double Sampling) circuits added, and are output each of 8 amplifier arrays. The control board converts the analog video signal into a 14-bit digital signal and outputs it to an external frame grabber through the USB2.0 interface.

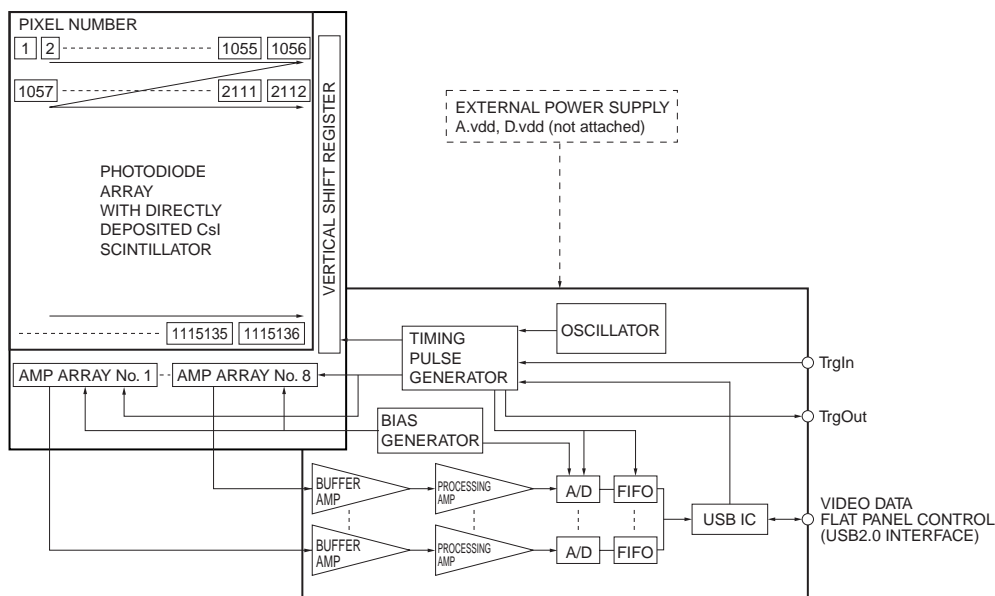

Note: Signals are read out in order of pixel number.

ACCC0268EB

■ General ratings

Parameter	Specification	Unit
Pixel size	50 × 50	μm
Photodiode area	52.8 × 52.8	mm
Number of pixels	1056 × 1056	pixels
Number of active pixels	1032 × 1032	pixels
Readout	Charge amplifier array	-
Video output	USB2.0	-
TrgIn, TrgOut	TTL	-
Scintillator	Direct deposition CsI	-

■ Absolute maximum ratings (Ta=25 °C)

Parameter	Symbol	Value	Unit
Supply voltage for digital circuitry (+5 V)	D.vdd	+6.0	V
Supply voltage for analog circuitry (+5 V)	A.vdd	+6.0	V
Operating temperature *1	Topr	0 to +35	°C
Storage temperature *1	Tstg	0 to +50	°C

*1: No condensation.

■ Specification (Ta=25 °C A.vdd= 5.0 V, D.vdd= 5.0 V)

Parameter	Symbol	Min.	Typ.	Max.	Unit
Frame rate (single operation)	Sf (int)	3.8	4	-	frames/s
Frame rate external (single operation)	Sf (ext)	-	Sf (int) to 0.5	-	frames/s
Noise (rms) *2	N (rms)	-	1250	-	electrons
Sensitivity *3	S	52	65	-	LSB/mR
Resolution *4	Reso	9	10	-	line pairs/mm
Saturation charge	Csat	-	6.4	-	M electrons
Dynamic range	-	-	5100	-	-
Defect line *5	-	-	-	10	lines
Output offset *6	-	-	260	800	LSB

*2: Internal trigger mode, single operation

*3: Mo target 30 kV, without filter

*4: Spatial frequency at CTF=5 %

*5: Without a couple of adjacent defect line.

A defect line is a horizontal or vertical line containing 4 or more pixels that produce less than 1/8 of the average output from surrounding pixels and are formed continuously from the opposite side of an amplifier array or a shift register.

*6: Average of all active pixels in single operation at Sf (int).

Note: X-ray energy range is less than 35 kVp (17 keV Mo source).

■ Resolution

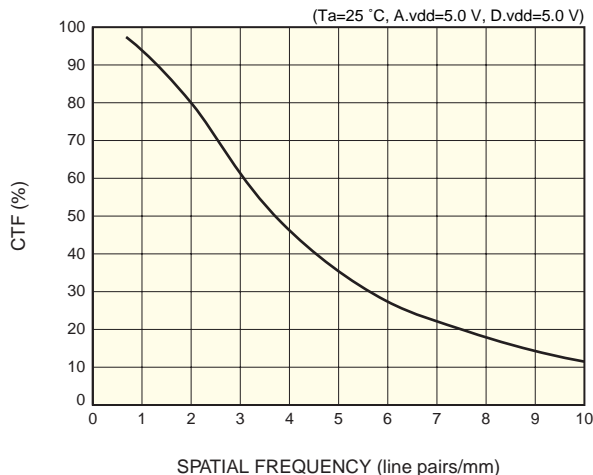

KACCB0154EA

■ System requirements

To operate C9730DK-10 at full performance, the following system and peripherals are required.

- PC: IBM compatible PC with USB2.0 running on Windows XP
- Power source: A. vdd = +5.0 ± 0.1 V (800 mA), D. vdd = +5.0 ± 0.1 V (300 mA)
Please use a series power supply is recommended. (Avoid using a switching power supply.) A power cable (terminated with a JSTJ-C9-2C plug at one end and open at the other end; 2 m; see Table 1.) and an external trigger cable (terminated with an FGG.0B.304.CLAD56 plug at one end and open at the other end; 5 m; see table 2.) comes supplied with C9730DK-10. C9730DK-10 does not include USB cable.

The voltages described above are specified at the flat panel sensor side. The impedance of the power cable attached with the flat panel sensor is low enough but it causes 0.1 V approx. drop. Therefore the voltage at the power source side should be set 0.1 V higher than the voltage specified above. Install a noise filter on the AC power input line to prevent surges on the AC line. DCAM-API (Digital Camera Application Programming Interface) produced by HAMAMATSU supports C9730DK-10. The driver software and DLL are included in DCAM-API. The latest version of the DCAM-API can be downloaded from <http://www.dcamapi.com/>. DCAM-SDK which includes function manual and sample software can be provided only for OEM customer. The USB receptacle is mini-B type. The mini-B USB cable is not attached. The earth terminal must be connected to a stable earth point to eliminate noise from surroundings.

Table 1: Pin assignment and cable color for 9-pin power receptacle

Pin No.	Color	Signal
1	Yellow	Digital GND
2	Blue	Digital GND
3	Gray	Analog GND
4	Black	Analog GND
5	Red	Analog GND
6	Green	Digital +5 V
7	Purple	Digital +5 V
8	White	Analog +5 V
9	Brown	Analog +5 V

9-pin receptacle: DE-9PF-N made by JAE (Japan Aviation Electronics Industry, Limited)

Mating plug: JST J-C9-2C made by JST Mfg. Co., Ltd.

Table 2: Pin assignment and color cable for 4-pin trigger cable

Pin No.	Color	Signal	
1	Blue	Twist pair	TrgIn
2	Orange		Digital GND
3	Green	Twist pair	TrgOut
4	Brown		Digital GND

4-pin receptacle: ECG. 0B. 304. CLL made by LEMO S. A.

Mating plug: FGG. 0B. 304. CLAD56 made by LEMO S. A.

■ Dimensional outline (unit: mm, tolerance: ±1 mm unless otherwise noted)

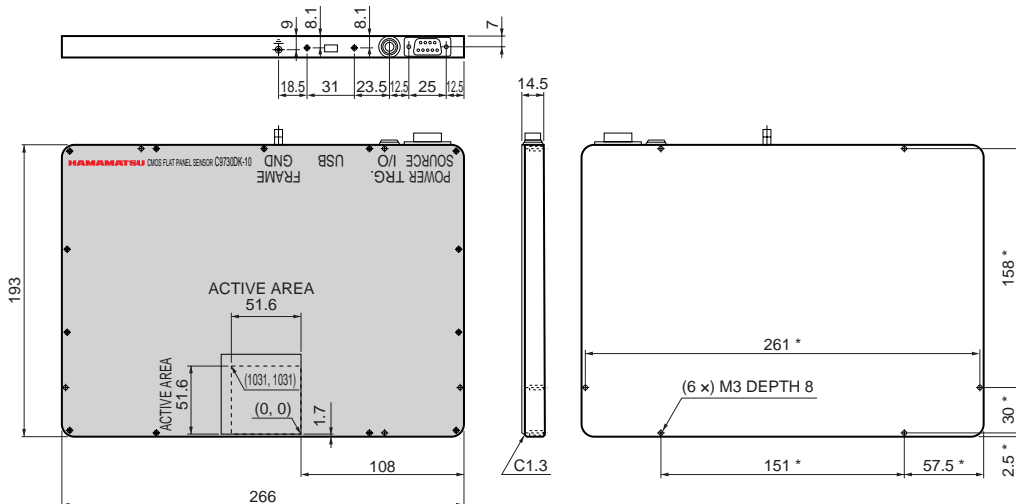

Top cover material including window is carbon fiber (1.0 mm thickness).
Weight: 1.3 kg

* ±0.5

KACCA0211EA

■ Notice

- Do not subject the Flat Panel Sensors to strong vibration or shock. (Strong shock such as drop impacts may cause permanent damage to these sensors.)
- Users must take responsibility for implementing X-ray shielding safety measures to avoid the risk of X-ray exposure.
- Data listed in this datasheet is defined at the time of shipment. Characteristics may vary somewhat due to exposure to X-rays so take proper countermeasures such as making periodic image correction.
- This product is warranted for a period of 12 months after the date of the shipment.

The warranty is limited to replacement or repair of any defective product due to defects in workmanship or materials used in manufacture. The warranty does not cover loss or damage caused by natural disaster, misuse (including modifications and any use not complying with the environment, application, usage and storage conditions described in this datasheet), or total X-ray radiation dose over 45000 Roentgen [less than 35 kVp (17 keV Mo source)] even within the warranty period.

HAMAMATSU

Information furnished by HAMAMATSU is believed to be reliable. However, no responsibility is assumed for possible inaccuracies or omissions. Specifications are subject to change without notice. No patent rights are granted to any of the circuits described herein. ©2007 Hamamatsu Photonics K.K.

HAMAMATSU PHOTONICS K.K., Solid State Division

1126-1 Ichino-cho, Higashi-ku, Hamamatsu City, 435-8558 Japan, Telephone: (81) 53-434-3311, Fax: (81) 53-434-5184, www.hamamatsu.com

U.S.A.: Hamamatsu Corporation: 360 Foothill Road, P.O.Box 6910, Bridgewater, N.J. 08807-0910, U.S.A., Telephone: (1) 908-231-0960, Fax: (1) 908-231-1218

Germany: Hamamatsu Photonics Deutschland GmbH: Arzbergerstr. 10, D-82211 Herrsching am Ammersee, Germany, Telephone: (49) 08152-3750, Fax: (49) 08152-2658

France: Hamamatsu Photonics France S.A.R.L.: 19, Rue du Saule Trapu, Parc du Moulin de Massy, 91882 Massy Cedex, France, Telephone: 33-(1) 69 53 71 00, Fax: 33-(1) 69 53 71 10

United Kingdom: Hamamatsu Photonics UK Limited: 2 Howard Court, 10 Tewin Road, Welwyn Garden City, Hertfordshire AL7 1BW, United Kingdom, Telephone: (44) 1707-294888, Fax: (44) 1707-325777

North Europe: Hamamatsu Photonics Norden AB: Smidesvägen 12, SE-171 41 Solna, Sweden, Telephone: (46) 8-509-031-00, Fax: (46) 8-509-031-01

Italy: Hamamatsu Photonics Italia S.R.L.: Strada della Moia, 1/E, 20020 Arese, (Milano), Italy, Telephone: (39) 02-935-81-733, Fax: (39) 02-935-81-741