

HD74LV2GT74A

Single D-type Flip Flops with Preset and Clear / CMOS Logic Level Shifter

REJ03D0146-0200Z
(Previous ADE-205-681A (Z))
Rev.2.00
Oct.17.2003

Description

The HD74LV2GT74A has independent data, preset, clear, and clock inputs Q and \bar{Q} outputs in an 8 pin package. The input data is transferred to the output at the rising edge of clock pulse CLK. The input protection circuitry on this device allows over voltage tolerance on the input, allowing the device to be used as a logic-level translator from 3.0 V CMOS Logic to 5.0 V CMOS Logic or from 1.8 V CMOS logic to 3.0 V CMOS Logic while operating at the high-voltage power supply. Low voltage and high-speed operation is suitable for the battery powered products (e.g., notebook computers), and the low power consumption extends the battery life.

Features

- The basic gate function is lined up as Renesas uni logic series.
- Supplied on emboss taping for high-speed automatic mounting.
- TTL compatible input level.
Supply voltage range : 3.0 to 5.5 V
Operating temperature range : -40 to +85°C
- Logic-level translate function
3.0 V CMOS logic → 5.0 V CMOS logic (@V_{CC} = 5.0 V)
1.8 V or 2.5 V CMOS logic → 3.3 V CMOS logic (@V_{CC} = 3.3 V)
- All inputs V_{IH} (Max.) = 5.5 V (@V_{CC} = 0 V to 5.5 V)
All outputs V_O (Max.) = 5.5 V (@V_{CC} = 0 V)
- Output current ±6 mA (@V_{CC} = 3.0 V to 3.6 V), ±12 mA (@V_{CC} = 4.5 V to 5.5 V)
- All the logical input has hysteresis voltage for the slow transition.
- Ordering Information

Part Name	Package Type	Package Code	Package Abbreviation	Taping Abbreviation (Quantity)
HD74LV2GT74AUSE	SSOP-8 pin	TTP-8DBV	US	E (3,000 pcs/reel)

HD74LV2GT74A

Outline and Article Indication

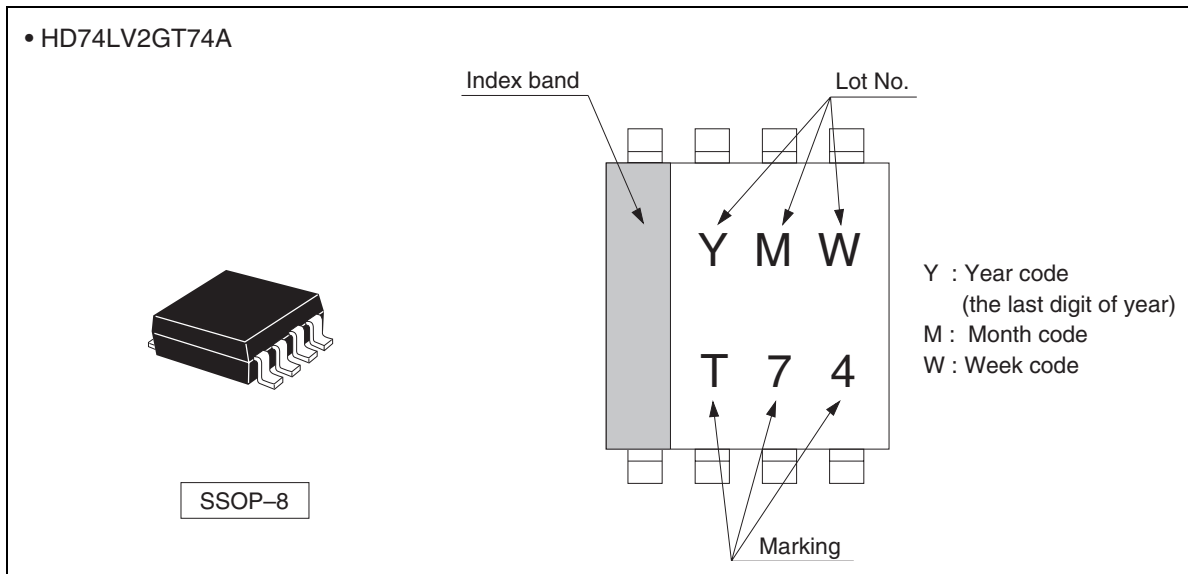

Function Table

Inputs				Outputs	
$\overline{\text{PRE}}$	$\overline{\text{CLR}}$	CLK	D	Q	$\overline{\text{Q}}$
L	H	X	X	H	L
H	L	X	X	L	H
L	L	X	X	H ^{*1}	H ^{*1}
H	H	↑	H	H	L
H	H	↑	L	L	H
H	H	↓	X	Q ₀	$\overline{\text{Q}}_0$

H : High level

L : Low level

X : Immaterial

↑ : Low to high transition

↓ : High to low transition

Q₀ : The level of Q immediately before the input conditions shown in the above table are determined.

Note : 1. Q and $\overline{\text{Q}}$ will remain high as long as preset and clear are low, but Q and $\overline{\text{Q}}$ are unpredictable, if preset and clear go high simultaneously.

Pin Arrangement

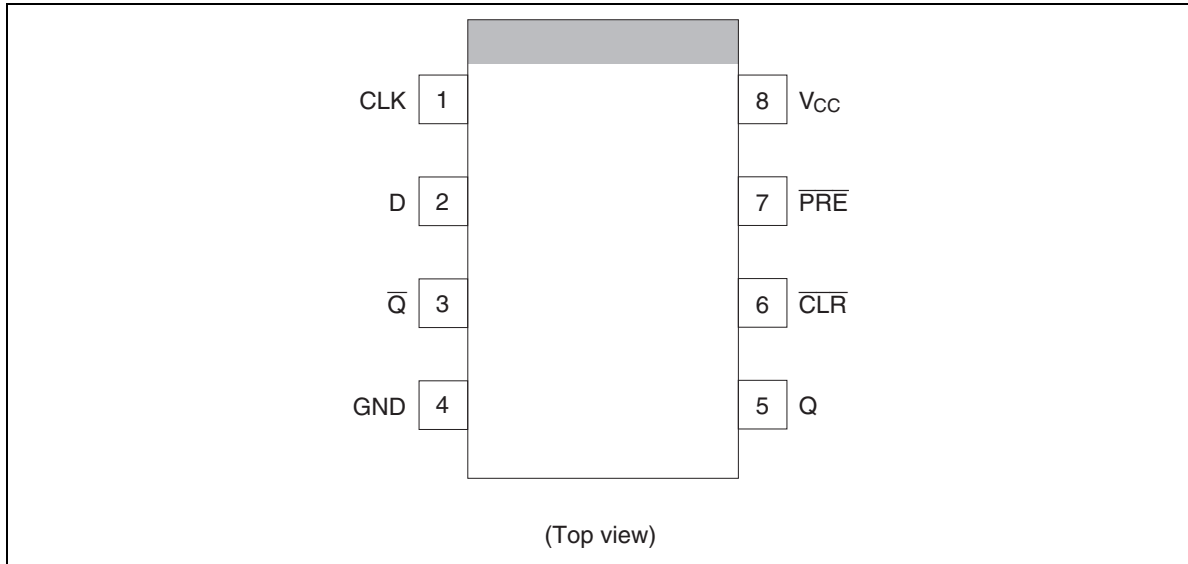

Absolute Maximum Ratings

Item	Symbol	Ratings	Unit	Test Conditions
Supply voltage range	V_{CC}	-0.5 to 7.0	V	
Input voltage range ^{*1}	V_I	-0.5 to 7.0	V	
Output voltage range ^{*1, 2}	V_O	-0.5 to $V_{CC} + 0.5$ -0.5 to 7.0	V	Output : H or L V_{CC} : OFF
Input clamp current	I_{IK}	-20	mA	$V_I < 0$
Output clamp current	I_{OK}	± 50	mA	$V_O < 0$ or $V_O > V_{CC}$
Continuous output current	I_O	± 25	mA	$V_O = 0$ to V_{CC}
Continuous current through V_{CC} or GND	I_{CC} or I_{GND}	± 50	mA	
Maximum power dissipation at $T_a = 25^\circ\text{C}$ (in still air) ^{*3}	P_T	200	mW	
Storage temperature	T_{stg}	-65 to 150	$^\circ\text{C}$	

- Notes: The absolute maximum ratings are values, which must not individually be exceeded, and furthermore no two of which may be realized at the same time.
1. The input and output voltage ratings may be exceeded if the input and output clamp-current ratings are observed.
 2. This value is limited to 5.5 V maximum.
 3. The maximum package power dissipation was calculated using a junction temperature of 150°C.

Recommended Operating Conditions

Item	Symbol	Ratings	Unit
Supply voltage	V_{CC}	3.0 to 5.5	V
Input voltage	V_{IN}	0 to 5.5	V
Output voltage	V_{OUT}	0 to V_{CC}	V
Operating temperature	T_{opr}	-40 to +85	°C
Input rise / fall time	t_r, t_f	0 to 100 ($V_{CC} = 3.0$ to 3.6 V) 0 to 20 ($V_{CC} = 4.5$ to 5.5 V)	ns

Note: Unused or floating inputs must be held high or low.

Logic Diagram

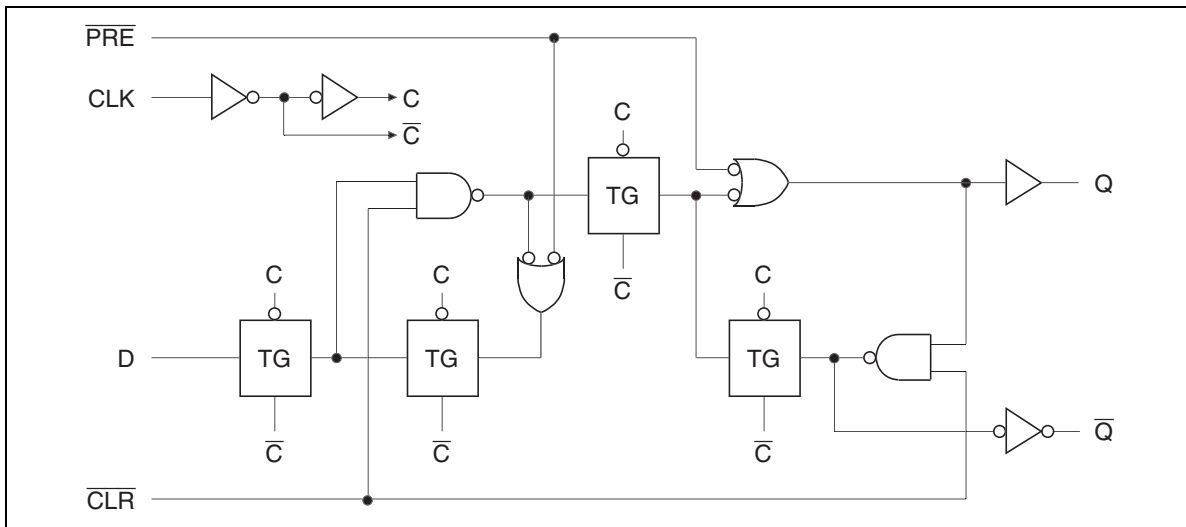

Electrical Characteristic

- $T_a = -40$ to 85°C

Item	Symbol	V_{CC} (V) *	Min	Typ	Max	Unit	Test condition
Input voltage	V_{IH}	3.0 to 3.6	1.5	—	—	V	
		4.5 to 5.5	2.0	—	—		
	V_{IL}	3.0 to 3.6	—	—	0.6		
		4.5 to 5.5	—	—	0.8		
Hysteresis voltage	V_H	3.3	—	0.10	—	V	$V_{T^+} - V_{T^-}$
		5.0	—	0.15	—		
Output voltage	V_{OH}	Min to Max	$V_{CC}-0.1$	—	—	V	$I_{OH} = -50 \mu\text{A}$
		3.0	2.48	—	—		$I_{OH} = -6 \text{ mA}$
		4.5	3.8	—	—		$I_{OH} = -12 \text{ mA}$
	V_{OL}	Min to Max	—	—	0.1		$I_{OL} = 50 \mu\text{A}$
		3.0	—	—	0.44		$I_{OL} = 6 \text{ mA}$
		4.5	—	—	0.55		$I_{OL} = 12 \text{ mA}$
Input current	I_{IN}	0 to 5.5	—	—	± 1	μA	$V_{IN} = 5.5 \text{ V or GND}$
Quiescent supply current	I_{CC}	5.5	—	—	10	μA	$V_{IN} = V_{CC}$ or GND , $I_O = 0$
	ΔI_{CC}	5.5	—	—	1.5	mA	One input $V_{IN} = 3.4 \text{ V}$, other input V_{CC} or GND
Output leakage current	I_{OFF}	0	—	—	5	μA	$V_O = 5.5 \text{ V}$
Input capacitance	C_{IN}	5.0	—	2.5	—	pF	$V_{IN} = V_{CC}$ or GND

Note: For conditions shown as Min or Max, use the appropriate values under recommended operating conditions.

Switching Characteristics

- $V_{CC} = 3.3 \pm 0.3$ V

Item	Symbol	$T_a = 25^\circ\text{C}$			$T_a = -40$ to 85°C		Unit	Test Conditions	FROM (Input)	TO (Output)
		Min	Typ	Max	Min	Max				
Maximum clock frequency	f_{\max}	80	140	—	70	—	MHz	$C_L = 15$ pF		
		50	90	—	45	—		$C_L = 50$ pF		
Propagation delay time	t_{PLH}	—	7.0	12.5	1.0	14.5	ns	$C_L = 15$ pF	$\overline{\text{PRE}}/\overline{\text{CLR}}$	Q or $\overline{\text{Q}}$
	t_{PHL}	—	8.0	12.0	1.0	14.0			CLK	
		—	9.0	16.0	1.0	18.0	ns	$C_L = 50$ pF	$\overline{\text{PRE}}/\overline{\text{CLR}}$	Q or $\overline{\text{Q}}$
		—	10.0	15.5	1.0	17.5			CLK	
Setup time	t_{su}	6.0	—	—	7.0	—	ns		D	
		5.0	—	—	5.0	—			$\overline{\text{PRE}}$ or $\overline{\text{CLR}}$ inactive	
Hold time	t_h	0.5	—	—	0.5	—	ns			
Pulse width	t_w	6.0	—	—	7.0	—	ns		$\overline{\text{PRE}}$ or $\overline{\text{CLR}}$	"L"
		6.0	—	—	7.0	—			CLK	"H" or "L"

- $V_{CC} = 5.0 \pm 0.5$ V

Item	Symbol	$T_a = 25^\circ\text{C}$			$T_a = -40$ to 85°C		Unit	Test Conditions	FROM (Input)	TO (Output)
		Min	Typ	Max	Min	Max				
Maximum clock frequency	f_{\max}	130	180	—	110	—	MHz	$C_L = 15$ pF		
		90	140	—	75	—		$C_L = 50$ pF		
Propagation delay time	t_{PLH}	—	5.0	7.7	1.0	9.0	ns	$C_L = 15$ pF	$\overline{\text{PRE}}/\overline{\text{CLR}}$	Q or $\overline{\text{Q}}$
	t_{PHL}	—	5.6	7.3	1.0	8.5			CLK	
		—	6.6	9.7	1.0	11.0	ns	$C_L = 50$ pF	$\overline{\text{PRE}}/\overline{\text{CLR}}$	Q or $\overline{\text{Q}}$
		—	7.2	9.3	1.0	10.5			CLK	
Setup time	t_{su}	5.0	—	—	5.0	—	ns		D	
		3.0	—	—	3.0	—			$\overline{\text{PRE}}$ or $\overline{\text{CLR}}$ inactive	
Hold time	t_h	0.5	—	—	0.5	—	ns			
Pulse width	t_w	5.0	—	—	5.0	—	ns		$\overline{\text{PRE}}$ or $\overline{\text{CLR}}$	"L"
		5.0	—	—	5.0	—			CLK	"H" or "L"

Operating Characteristics

- $C_L = 50 \text{ pF}$

Item	Symbol	V_{CC} (V)	$T_a = 25^\circ\text{C}$			Unit	Test Conditions
			Min	Typ	Max		
Power dissipation capacitance	C_{PD}	5.0	—	14.0	—	pF	$f = 10 \text{ MHz}$

Test Circuit

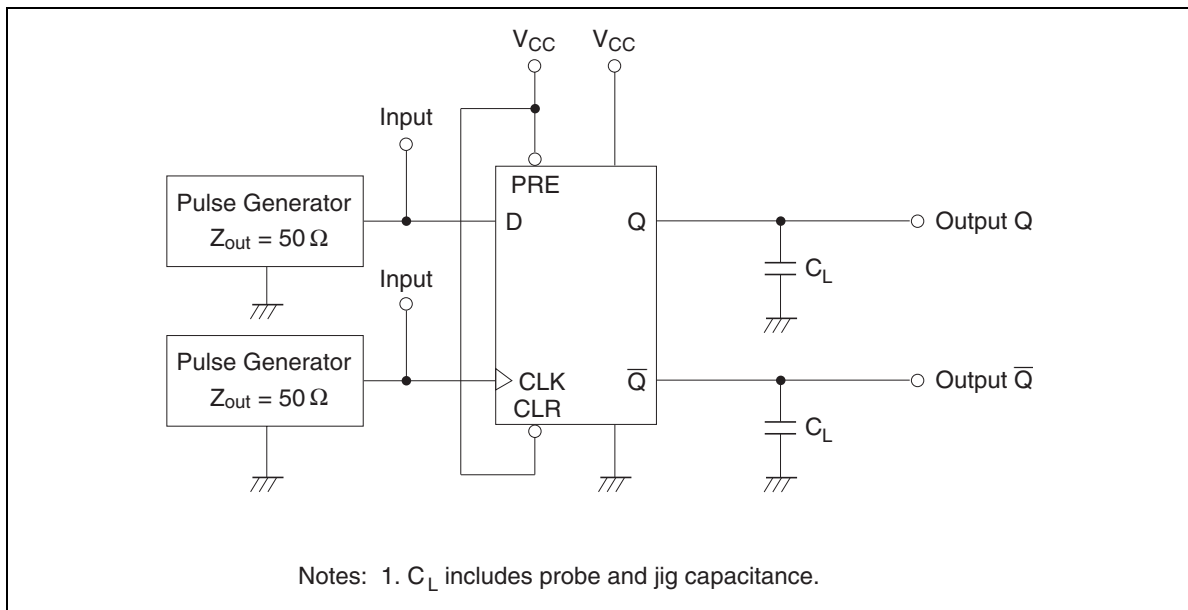

• Waveform – 1

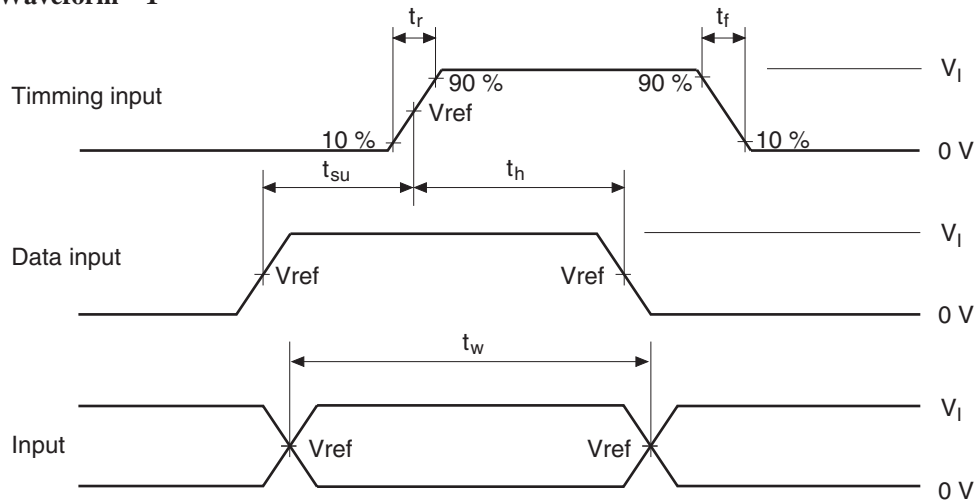

• Waveform – 2

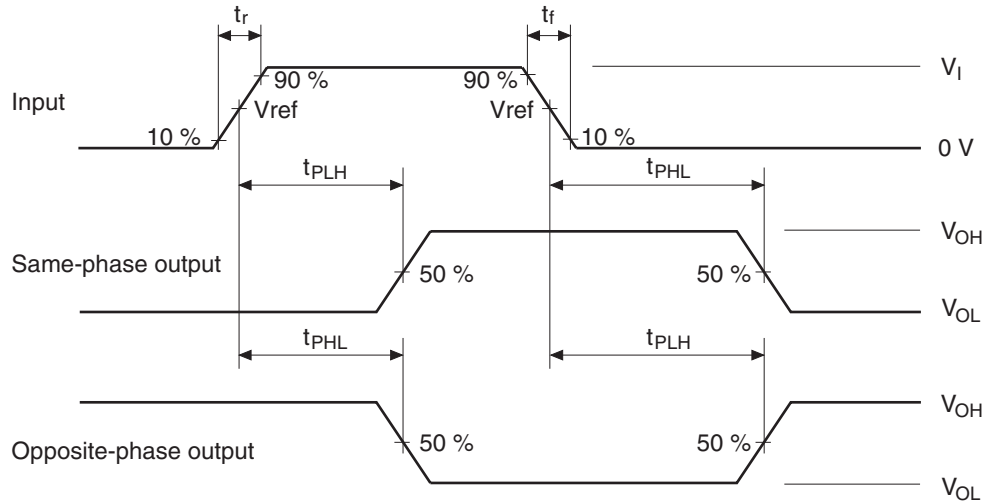

V_{CC} (V)	INPUTS		Vref
	V_I	t_r / t_f	
3.3 ± 0.3	2.5 V	≤ 3.0 ns	50%
5.0 ± 0.5	3 V	≤ 3.0 ns	1.5 V

- Notes: 1. Input waveform : PRR ≤ 1 MHz, $Z_o = 50 \Omega$.
 2. The output are measured one at a time with one transition per measurement.

Package Dimensions

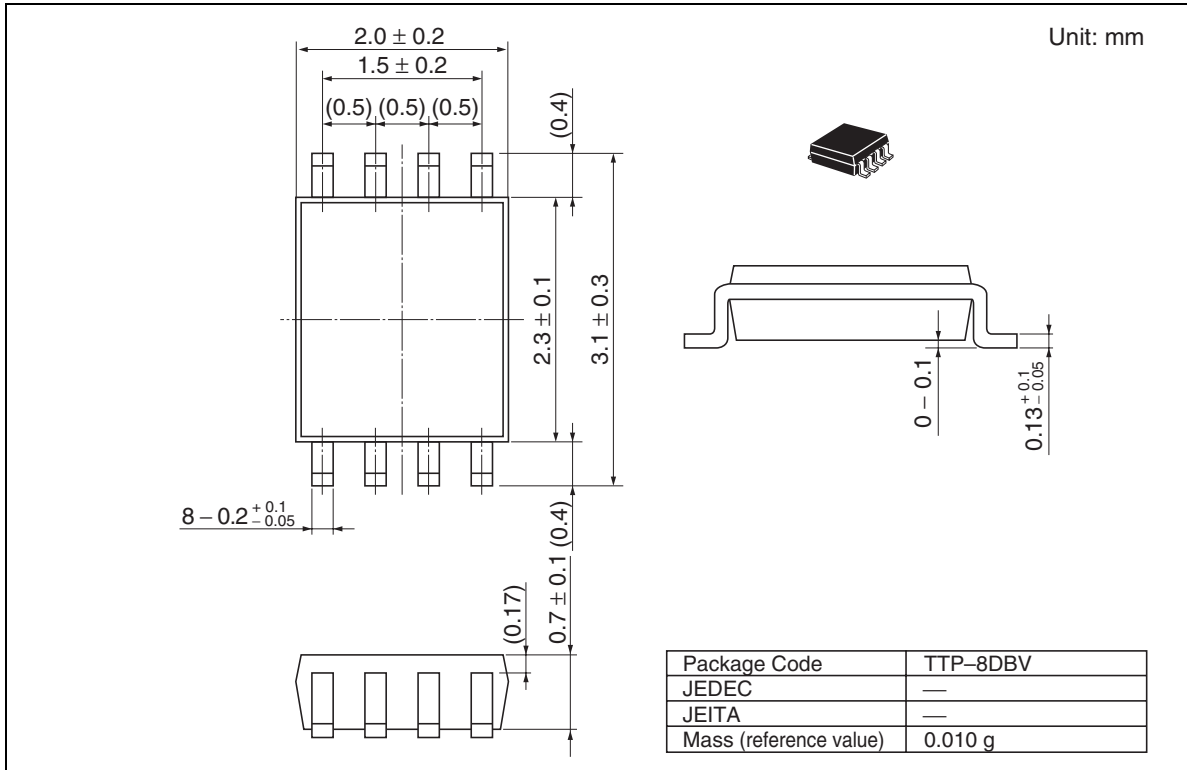

RENESAS Technology Corp. Sales Strategic Planning Div. Nippon Bldg., 2-6-2, Ohte-machi, Chiyoda-ku, Tokyo 100-0004, Japan

Keep safety first in your circuit designs!

1. Renesas Technology Corp. puts the maximum effort into making semiconductor products better and more reliable, but there is always the possibility that trouble may occur with them. Trouble with semiconductors may lead to personal injury, fire or property damage.
Remember to give due consideration to safety when making your circuit designs, with appropriate measures such as (i) placement of substitutive, auxiliary circuits, (ii) use of nonflammable material or (iii) prevention against any malfunction or mishap.

Notes regarding these materials

1. These materials are intended as a reference to assist our customers in the selection of the Renesas Technology Corp. product best suited to the customer's application; they do not convey any license under any intellectual property rights, or any other rights, belonging to Renesas Technology Corp. or a third party.
 2. Renesas Technology Corp. assumes no responsibility for any damage, or infringement of any third-party's rights, originating in the use of any product data, diagrams, charts, programs, algorithms, or circuit application examples contained in these materials.
 3. All information contained in these materials, including product data, diagrams, charts, programs and algorithms represents information on products at the time of publication of these materials, and are subject to change by Renesas Technology Corp. without notice due to product improvements or other reasons. It is therefore recommended that customers contact Renesas Technology Corp. or an authorized Renesas Technology Corp. product distributor for the latest product information before purchasing a product listed herein.
The information described here may contain technical inaccuracies or typographical errors.
Renesas Technology Corp. assumes no responsibility for any damage, liability, or other loss rising from these inaccuracies or errors.
Please also pay attention to information published by Renesas Technology Corp. by various means, including the Renesas Technology Corp. Semiconductor home page (<http://www.renesas.com>).
 4. When using any or all of the information contained in these materials, including product data, diagrams, charts, programs, and algorithms, please be sure to evaluate all information as a total system before making a final decision on the applicability of the information and products. Renesas Technology Corp. assumes no responsibility for any damage, liability or other loss resulting from the information contained herein.
 5. Renesas Technology Corp. semiconductors are not designed or manufactured for use in a device or system that is used under circumstances in which human life is potentially at stake. Please contact Renesas Technology Corp. or an authorized Renesas Technology Corp. product distributor when considering the use of a product contained herein for any specific purposes, such as apparatus or systems for transportation, vehicular, medical, aerospace, nuclear, or undersea repeater use.
 6. The prior written approval of Renesas Technology Corp. is necessary to reprint or reproduce in whole or in part these materials.
 7. If these products or technologies are subject to the Japanese export control restrictions, they must be exported under a license from the Japanese government and cannot be imported into a country other than the approved destination.
Any diversion or reexport contrary to the export control laws and regulations of Japan and/or the country of destination is prohibited.
 8. Please contact Renesas Technology Corp. for further details on these materials or the products contained therein.
-



RENESAS SALES OFFICES

<http://www.renesas.com>

Renesas Technology America, Inc.
450 Holger Way, San Jose, CA 95134-1368, U.S.A
Tel: <1> (408) 382-7500 Fax: <1> (408) 382-7501

Renesas Technology Europe Limited.
Dukes Meadow, Millboard Road, Bourne End, Buckinghamshire, SL8 5FH, United Kingdom
Tel: <44> (1628) 585 100, Fax: <44> (1628) 585 900

Renesas Technology Europe GmbH
Dornacher Str. 3, D-85622 Feldkirchen, Germany
Tel: <49> (89) 380 70 0, Fax: <49> (89) 929 30 11

Renesas Technology Hong Kong Ltd.
7/F., North Tower, World Finance Centre, Harbour City, Canton Road, Hong Kong
Tel: <852> 2265-6688, Fax: <852> 2375-6836

Renesas Technology Taiwan Co., Ltd.
FL 10, #99, Fu-Hsing N. Rd., Taipei, Taiwan
Tel: <886> (2) 2715-2888, Fax: <886> (2) 2713-2999

Renesas Technology (Shanghai) Co., Ltd.
26/F., Ruijin Building, No.205 Maoming Road (S), Shanghai 200020, China
Tel: <86> (21) 6472-1001, Fax: <86> (21) 6415-2952

Renesas Technology Singapore Pte. Ltd.
1, Harbour Front Avenue, #06-10, Keppel Bay Tower, Singapore 098632
Tel: <65> 6213-0200, Fax: <65> 6278-8001