

### Typical Applications

This HMC-MDB218 is ideal for:

- Short-Haul / High Capacity Radios
- SATCOM
- Military Radar, ECM & EW
- Sensors
- Test & Measurement Equipment

### Functional Diagram

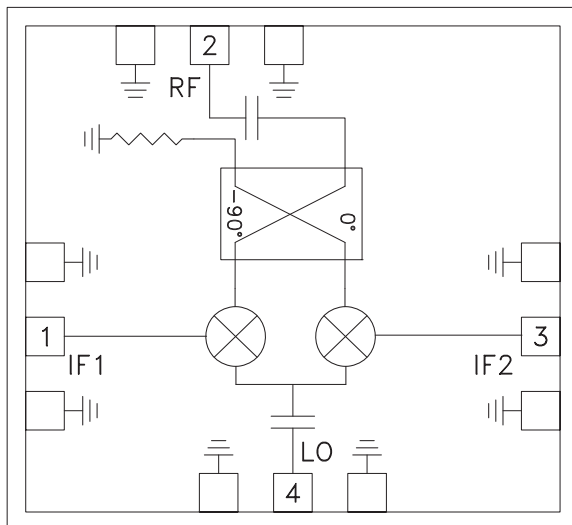

### Features

- Wide IF Bandwidth: DC - 3 GHz
- RF Frequency: 54 to 64 GHz
- LO Frequency: 27 to 32 GHz
- High Image Rejection: 30 dB
- Passive; No DC Bias Required
- Die Size: 1.54 x 1.41 x 0.1 mm

### General Description

The HMC-MDB218 is a sub-harmonically pumped (x2) MMIC Mixer which can be used as either an image reject mixer (IRM) or a single sideband upconverter. This passive MMIC mixer is fabricated with GaAs Heterojunction Bipolar Transistor (HBT) Shottky diode technology. For downconversion applications, an external quadrature hybrid can be used to select the desired sideband while rejecting image signals. All bond pads and the die backside are Ti/Au metallized and the Shottky devices are fully passivated for reliable operation. The HMC-MDB218 Sub Harmonic IRM is compatible with conventional die attach methods, as well as thermocompression and thermosonic wire bonding, making it ideal for MCM and hybrid microcircuit applications. All data shown herein is measured with the chip in a 50 Ohm environment and contacted with RF probes.

### Electrical Specifications\*, $T_A = 25^\circ\text{C}$ , $IF = 1\text{ GHz}$ , $LO = +10\text{ dBm}$

Parameter	Min.	Typ.	Max.	Units
Frequency Range, RF		54 - 64		GHz
Frequency Range, LO		27 - 32		GHz
Frequency Range, IF		DC - 3		GHz
Conversion Loss		12.5	14	dB
1 dB Compression (Input)		-2		dBm
Image Rejection		30		dB
LO to RF Isolation		30		dB
LO to IF Isolation		30		dB
IP3 (Input)		7		dBm
Amplitude Balance		0.3		dB
Phase Balance		1		Deg

\* Unless otherwise indicated, all measurements are from probed die

**GaAs MMIC SUB-HARMONIC  
IRM MIXER, 54 - 64 GHz**

**Downconverter Conversion Loss [1]**

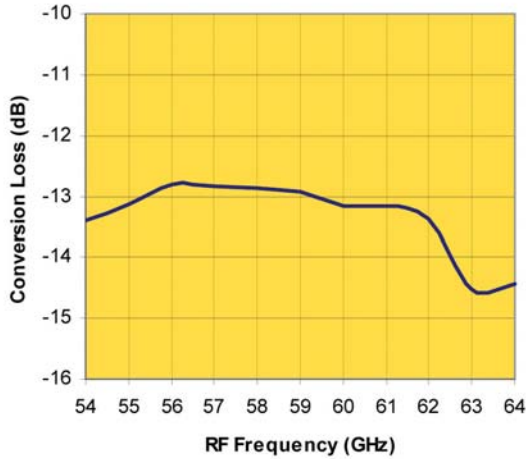

[1] LO = 27 - 30 GHz  
IF = 1 GHz  
PLO = +10 dBm  
PRF = -20 dBm

**RF Port Return Loss [2]**

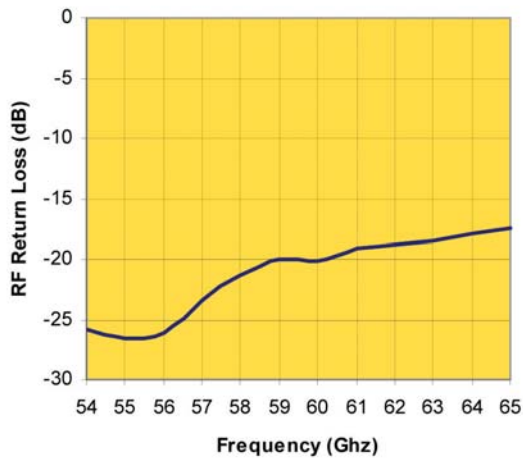

**IF Port Return Loss [2]**

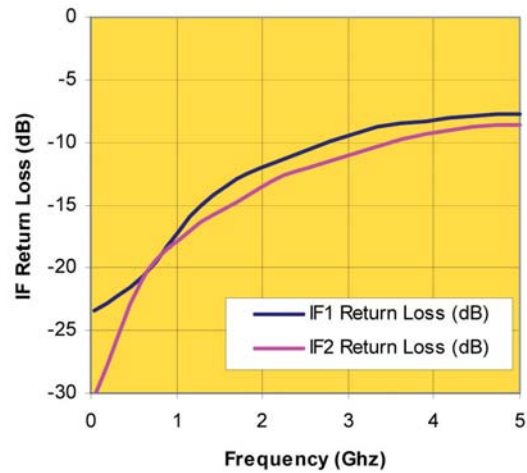

[2] LO = 29.5 GHz, PLO = 10 dBm

Note 1: Measured Performance Characteristics ( $T_{op} = 25^{\circ}C$ )

Note 2: Single side band measurement without  $90^{\circ}$  hybrid, and second IF port terminated.

**Absolute Maximum Ratings**

LO Drive	16 dBm
Storage Temperature	-65 °C to 150 °C
Operating Temperature	-55 °C to 85 °C



**ELECTROSTATIC SENSITIVE DEVICE  
OBSERVE HANDLING PRECAUTIONS**

**Outline Drawing**

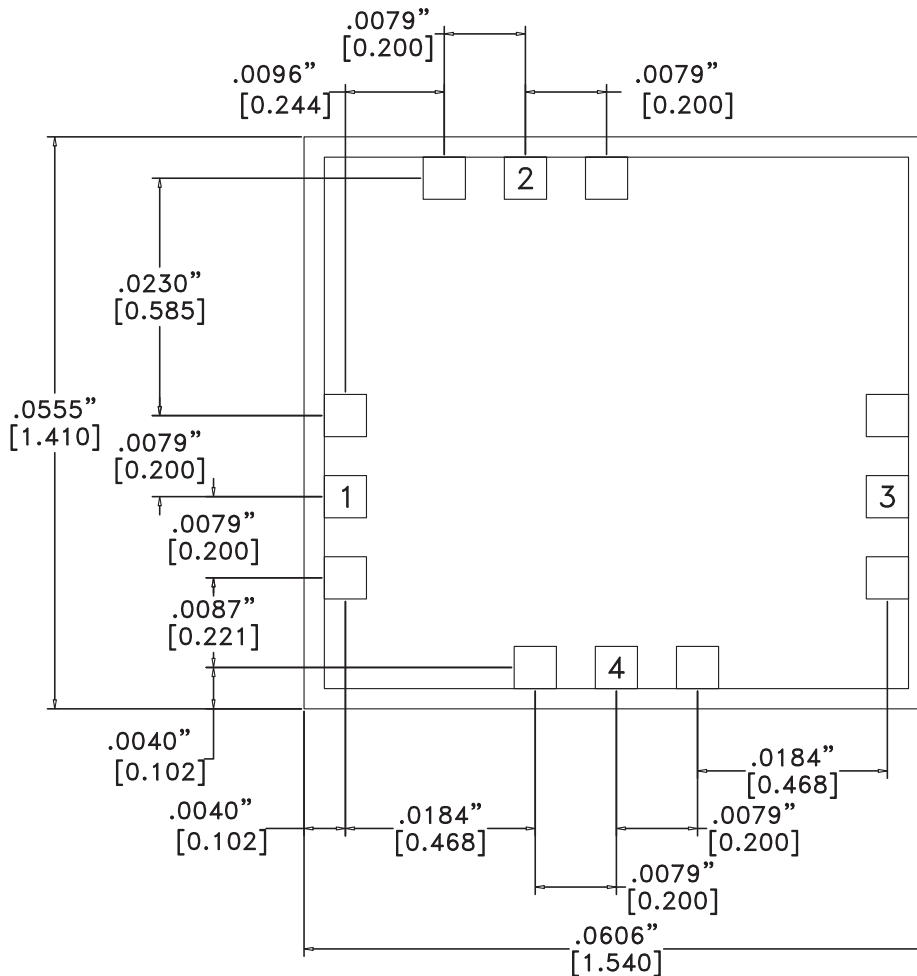

**NOTES:**

1. ALL DIMENSIONS ARE IN INCHES [MM].
2. TYPICAL BOND PAD IS .004" SQUARE.
3. BACKSIDE METALLIZATION: GOLD.
4. BACKSIDE METAL IS GROUND.
5. BOND PAD METALLIZATION: GOLD.
6. CONNECTION NOT REQUIRED FOR UNLABELED BOND PADS.
7. OVERALL DIE SIZE ±.002"

**Application Circuits**

Application circuit 1 shows the mixer equivalent circuit. Application Circuit 2 depicts the mixer with a 90° hybrid used to achieve signal image rejection. All RF parameters are specified with an ideal 90° hybrid on IF output ports. Conversion loss is measured (on wafer) at IF1 and/or IF2 (Application Circuit 1) with the second IF port terminated into 50 ohms. Three dB is then added to compensate for an ideal hybrid. The IP3 is stated as an input IP3 number and is obtained via a two-tone measurement.

**Application Circuit 1**

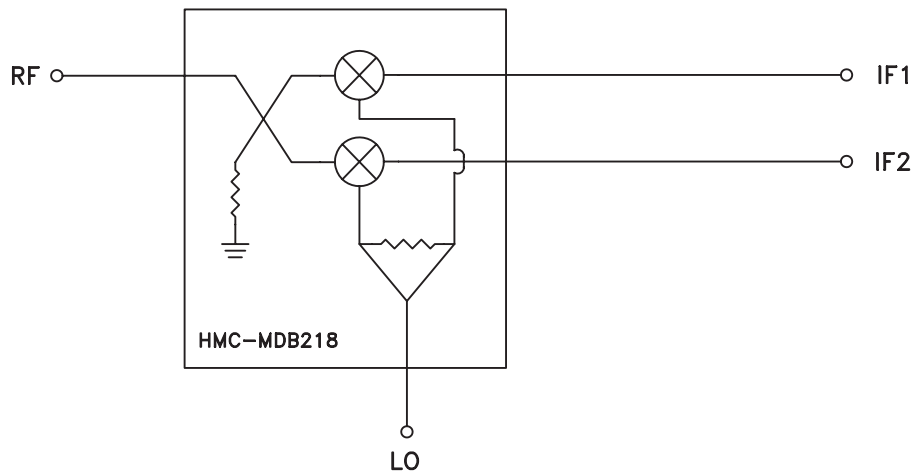

**Application Circuit 2**

