

Description

The YB1300S is a switched capacitor DC/DC boost converter that produces a regulated 5V output. The input voltage range is from 2.7V to 5.0V that makes the YB1300S ideally for a single cell Li-Ion battery source.

The YB1300S works well for step-up applications without the need for an inductor. The 1MHz switching frequency allows the use of small SMD capacitors. The YB1300S provides thermal protection, short-circuit current limit protection. In order to prevent in-rush current effectively, it provides automatic soft-start. The shutdown current is less than 0.1µA. The YB1300S is available in a 6-pin SOT23 package.

Features

- Switched-Capacitor Step-Up Operation
- Input Range : 2.7V to 5.0V
- Shutdown Mode
- 5V/4.5V Fix Output Voltage
- 1MHz Internal Oscillator
- Thermal Protection Shutdown
- Output Short-circuit Current Limit Protection
- Automatic Soft-Start Reduces In-Rush Current
- SOT23-6 Package

Applications

- Cellular Phones
- White LED Drivers
- Smart Card Reader
- PCMCIA Cards
- Li-Ion Battery Backup Supplies

Typical Application Circuit

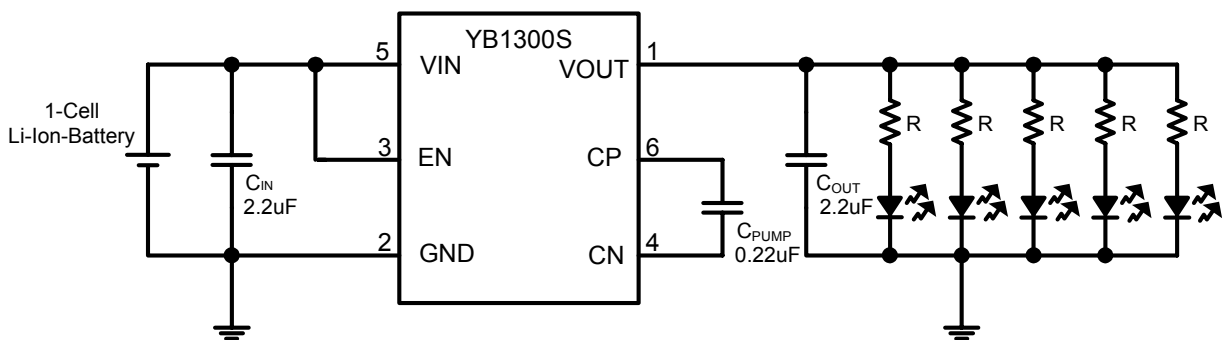

Figure 1. Typical application circuit

Pin Configuration

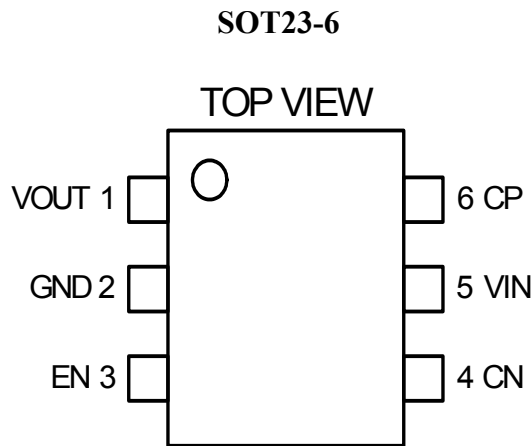

Figure 2. Pin configuration

Pin Description

Table 1

Pin	Name	Description
1	V_{OUT}	Regulated output voltage. V_{OUT} should be bypassed with a low ESR capacitor for the best performance.
2	GND	Ground pin.
3	EN	1.2V or above will turn on the IC. Below 0.4V will put the chip in the shutdown mode.
4	CN	Pumping capacitor negative terminal.
5	V_{IN}	Input supply voltage. V_{IN} should be bypassed with a 2.2 μ F low ESR capacitor.
6	CP	Pumping capacitor positive terminal.

Ordering Information

Order Number	Package Type	Supplied as	Package Marking
YB1300ST26S500	SOT23-6	3000 units Tape & Reel	TBA
YB1300ST26S450	SOT23-6	3000 units Tape & Reel	TBB

Absolute Maximum Ratings

- Supply Voltage5.5V
- Output Voltage5.5V
- Output Short-Circuit Duration Continuous
- Junction Temperature Range +125°C
- Storage Temperature Range -65°C to +150°C
- Lead Temperature..... +250°C
- ESD Susceptibility
 - HBM (Human Body Mode) 2KV
 - MM (Machine Mode).....200V

Recommended Operating Conditions

- Input Supply Voltage..... 2V to 5V
- Operating Temperature..... -40°C to +85°C

Electrical Characteristics

At $T_A=25^\circ\text{C}$, $V_{IN}=3.2\text{V}$, $I_{OUT}=10\text{mA}$, $C_{IN}=C_{OUT}=2.2\mu\text{F}$, $C_{PUMP}=0.22\mu\text{F}$, $V_{ENABLE}=V_{IN}$, unless otherwise noted.

Table 2

Symbol	Function Parameter	Test Conditions	Min	Typ	Max	Units
V_{IN}	Input Voltage		2.7		5.0	V
V_{OUT}	Output Voltage	$V_{IN}=3.3\text{V}$, $I_{OUT}=60\text{mA}$	4.8	5.0	5.2	V
I_{OUT}	Maximum Output Current	$V_{IN}>3.2\text{V}$	100		250	mA
I_{SC}	Short Circuit Current	$V_{IN}=4.5\text{V}$		80		mA
F_{OSC}	Oscillator Frequency		0.8	1	1.2	MHz
η	Efficiency	$I_{OUT} = 20\text{mA}$, $V_{IN}=2.7\text{V}$		90		%
V_R	Ripple Voltage	$V_{IN}=3.4\text{V}$, $I_{OUT} = 60\text{mA}$		35		mVpp
V_{IH}	Enable Control (High)	$V_{in}=5.0\text{V}$	1.2			V
V_{IL}	Enable Control (Low)	$V_{in}=5.0\text{V}$	-0.2		0.4	V
T_{ST}	Thermal Shutdown	Shutdown Temperature		~160		°C
T_{RT}	Thermal Recovery	Recovery Temperature		~140		°C
I_{QC}	Supply Current (Quiescent)	$V_{IN} = 3.4\text{V}$, $I_{OUT} = 0\text{mA}$		1		mA
I_{SC}	Supply Current (Shutdown)	$V_{IN} = 2.7\text{-}5.0\text{V}$, $\text{Enable}=0\text{V}$		~0.1		μA

Typical Characteristics

At $T_A=25^{\circ}\text{C}$, $V_{IN}=3.2\text{V}$, $I_{OUT}=10\text{mA}$, $C_{IN}=C_{OUT}=2.2\mu\text{F}$, $C_{PUMP}=0.22\mu\text{F}$, $V_{ENABLE}=V_{IN}$, unless otherwise noted.

Output Voltage vs. Output Current

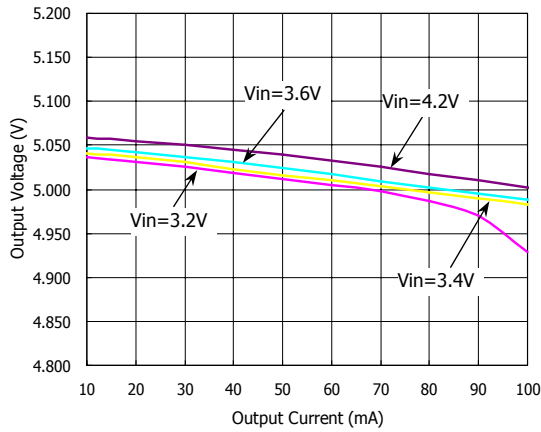

Output Voltage vs. Input Voltage

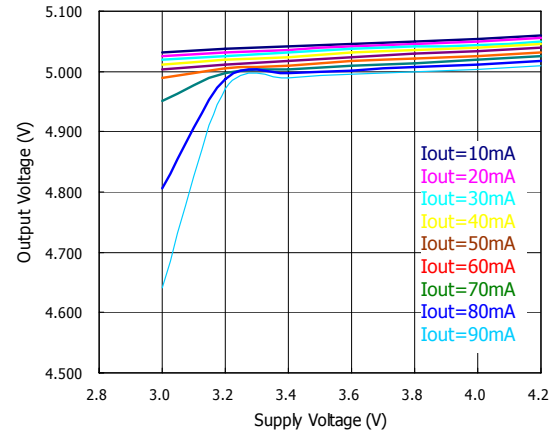

Efficiency vs. Output Current

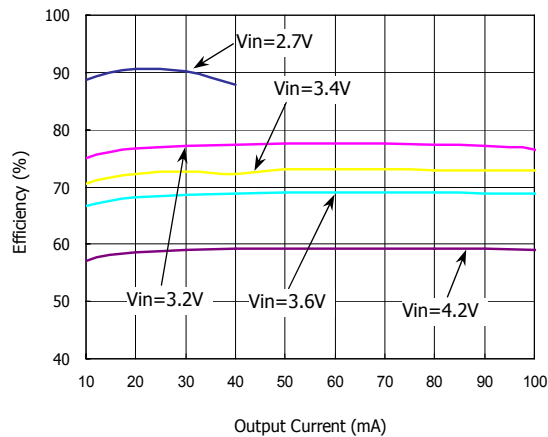

Input Short-Circuit Current vs. Input Voltage

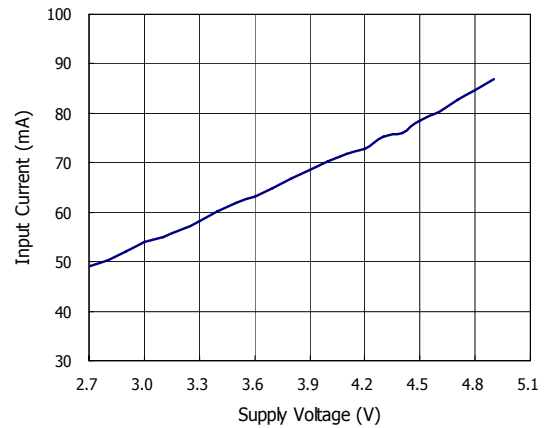

Output Ripple with Iout=60mA

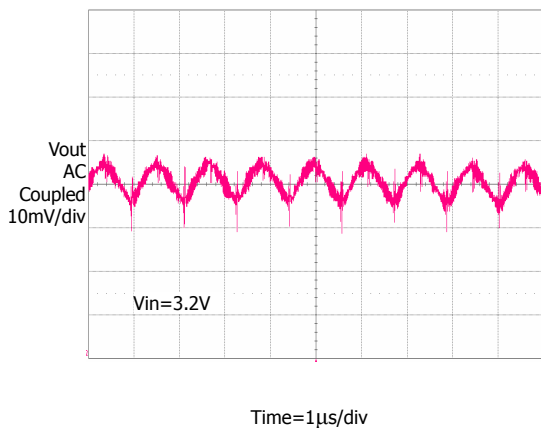

Output Ripple vs. Output Current

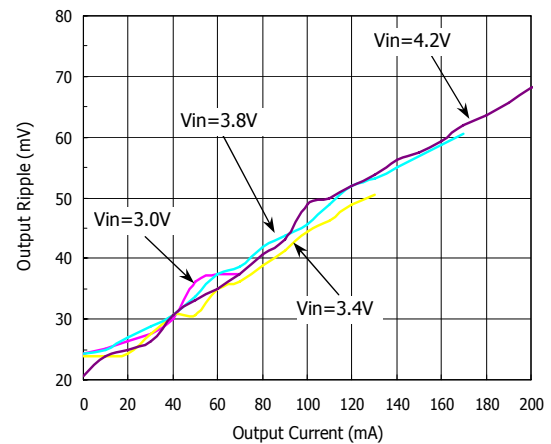

Output Ripple with Iout=100mA

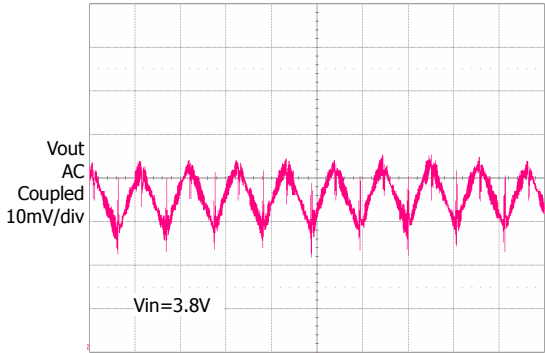

Time=1µs/div

Inrush Current and Start Up Time

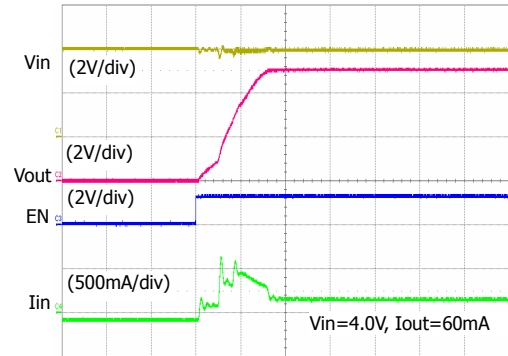

Time=100µs/div

Inrush Current and Start Up Time

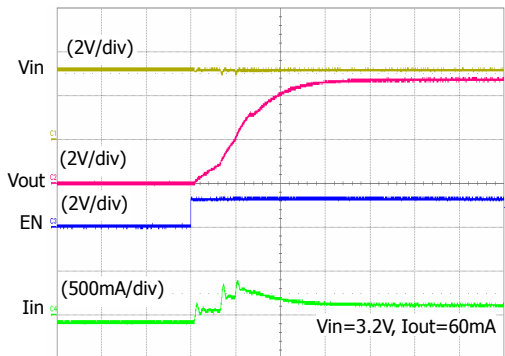

Time=100µs/div

Normal Operation

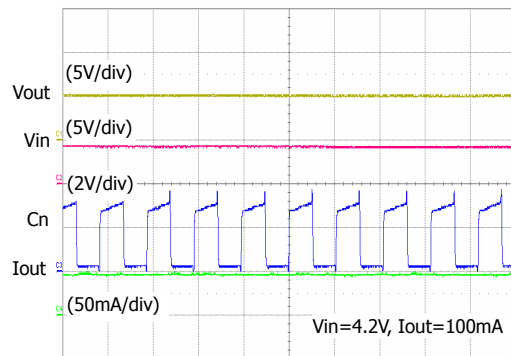

Time=1µs/div

Normal Operation

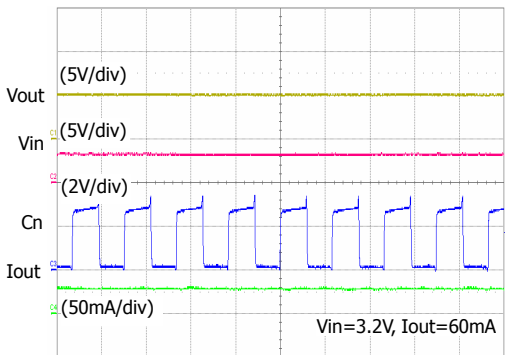

Time=1µs/div

Output Voltage V.S Output Current

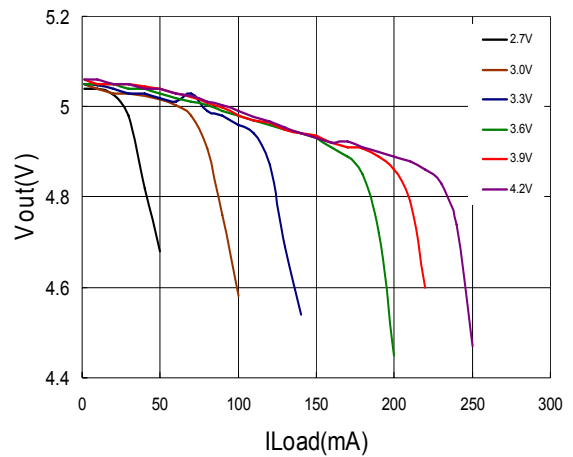

Functional Block

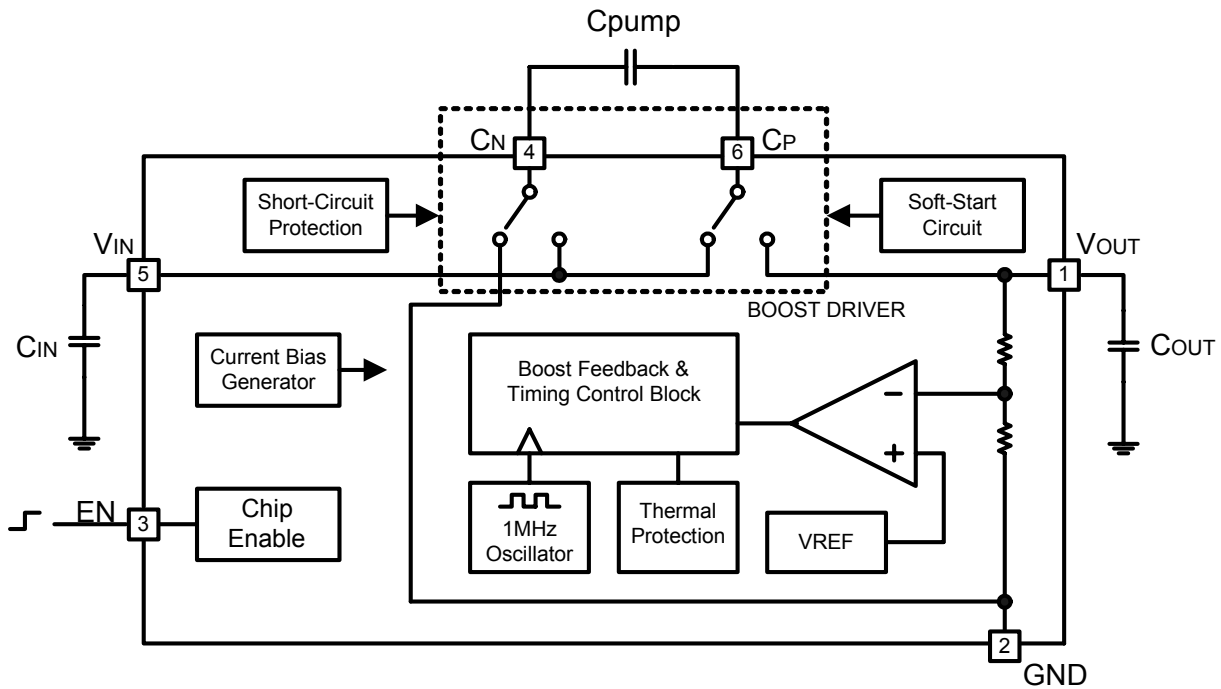

Figure 3. Block Diagram

Functional Description

The YB1300S regulated charge pump provides a regulated 5V output voltage for input voltages between 2.7V and 5V. This is accomplished by a step-up or boost mode of operation. A conversion clock of 50% duty cycle is generated. During the first half cycle, the pumping capacitor C_{PUMP} charges to V_{IN} . During the second half cycle, the voltage on C_{PUMP} is added to V_{IN} , then deliver to V_{OUT} . The output voltage is regulated by skipping clock cycles as necessary.

Soft-Start and Short-Circuit Protection Circuitry

The YB1300S includes soft-start circuitry to

limit inrush current at turn-on. When starting up, the output capacitor is charged through the charge-pump capacitor with a limited current source. When the output voltage approached to its design value, the soft-start is terminated and normal operation begins. If an overload condition occurs, for example, the output is shorted to ground, the output current is limited by the YB1300S switching technique.

Thermal Protection

The regulator has thermal shutdown circuitry that protects it from damage caused by high temperature conditions. The thermal protection circuitry shut down

the device when the junction temperature reached approximately 160°C, allowing the device to cool. When the junction temperature cools to approximately 140°C, the device is automatically reenabled. Continuously running the regulator into thermal shutdown can degrade reliability.

Shutdown Mode

A control pin on the regulator can be used to place the device into an energy-saving shutdown mode. In this mode, the output is disconnected from the input.

Layout Consideration

Due to large transient currents and high switching frequency produced by the YB1300S, careful consideration of PCB layout is necessary. In order to minimize both input and output ripple, keep the capacitors as close as possible to the regulator using short, direct circuit traces. A ground plane and short connections to all capacitors will improve performance and

ensure proper regulation under all conditions. Figure 4 and Figure 5 show the recommended layout configuration.

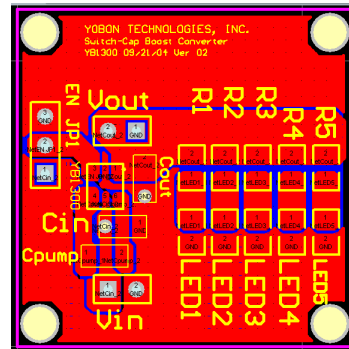

Figure 4. Top layer

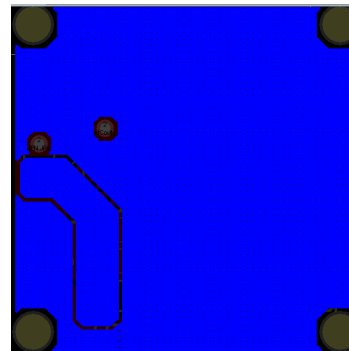
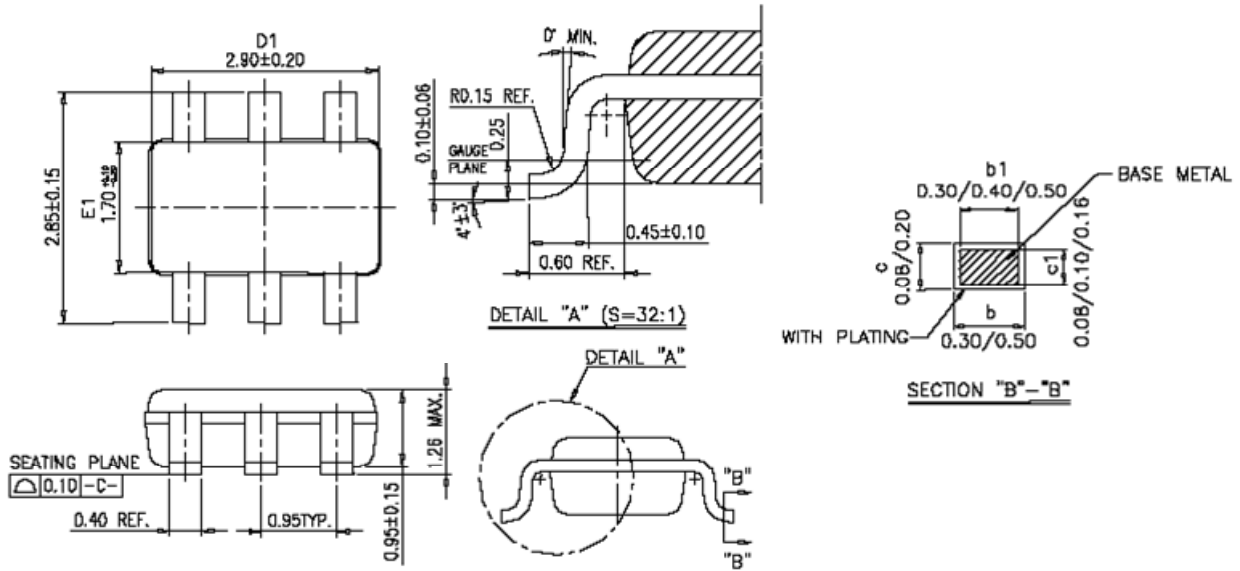

Figure 5. Bottom layer

Package Information



Notes:

1. Dimension D1 & E1 does not include mold protrusion.
2. Coplanarity of all lead shall be (Before test) 0.1 MAX. from the seating plane. Unless otherwise specified.